

USER MANUAL



2 Inputs
RTD, TC, mA
V, mV, Ω , BIN



2 Outputs
OC



Ethernet
MODBUS-TCP
MQTT



RS485
MODBUS-RTU



Alarms
STB function
LATCH



USB
port COM
MODBUS-RTU



Software
ARSOFT-CFG



Access protection
Password

AR595

TWO-CHANNEL UNIVERSAL TRANSDUCER

WITH USB, RS485 and ETHERNET INTERFACES



*Thank you for choosing our product.
This manual will enable proper handling, secure use and full use of the transducer's capacity.
Before assembling and starting the device please read and understand this manual.
If you have additional questions, please contact our technical consultant.*

TABLE OF CONTENTS

1. SAFETY PRINCIPLES	3
2. ASSEMBLY RECOMMENDATIONS	3
3. GENERAL CHARACTERISTICS OF THE TRANSDUCER. ACCESSORIES AND KIT CONTENTS	3
4. TECHNICAL DATA	4
5. HOUSING DIMENSIONS AND INSTALLATION DATA	5
6. DESCRIPTION OF CLAMPING RAILS AND ELECTRICAL CONNECTIONS AND LEDS	5
7. FUNCTION BINARY INPUT BIN	6
8. SETTING OF CONFIGURATION PARAMETERS	6
9. OUTPUT OPERATION CONFIGURATION	9
10. SIGNALING OF MEASUREMENT ERRORS	10
11. SERIAL COMMUNICATION. AVAILABLE SOFTWARE AND USB DRIVERS	10
11.1. MQTT PROTOCOL	10
11.2. MODBUS-TCP SERIAL TRANSMISSION PROTOCOL	11
11.3. RS485 COMMUNICATION INTERFACE (according to EIA RS-485)	11
11.4. MODBUS-RTU SERIAL TRANSMISSION PROTOCOL (SLAVE)	12
11.5. MAP OF DEVICE REGISTERS FOR MODBUS-RTU / TCP	13
12. OWN NOTES	13



Pay special attention to the texts marked with this sign

The manufacturer reserves the right to make changes to the design and software of the device without deteriorating its technical parameters.

1. SAFETY PRINCIPLES



Before using the device, please read this manual carefully, and:

- a) in order to avoid electric shock or damage to the device mechanical and electrical assembly should be commissioned to qualified personnel
- b) before turning on the power, make sure that all cables have been connected correctly
- c) before modifying cable connections, disconnect the voltage connected to the device
- d) ensure proper working conditions, compliant with the technical data of the device ([chapter 4](#), supply voltage, humidity, temperature, etc.), do not expose the device to direct and strong influence of heat radiation

2. ASSEMBLY RECOMMENDATIONS



The device has been designed to provide an adequate level of resistance to most of the disturbances that can occur in industrial and home environments. In environments with an unknown/high level of interference, it is recommended to use the following measures to prevent any possible disruption of the device's operation:

- a) do not supply power to the device from the same lines as large capacity devices without proper mains filters,
- b) for power, sensor and signal cables, use shielding and ferrite filters, where the filter and screen grounding (single point) should be as close as possible to the instrument
- c) avoid laying measuring (signal) wires in the immediate vicinity and parallel to power and supply cables,
- d) it is recommended to twist signal wires in pairs or use a ready twisted-pair cable wire,
- e) use the same cables for resistance sensors in a 3-wire connection,
- f) avoid the proximity of remotely controlled devices, electromagnetic meters, high power loads, loads with phase or group power control and other devices generating large impulse noise,
- g) ground or neutralize the metal rails on which the rail devices are mounted.

3. GENERAL CHARACTERISTICS OF THE TRANSDUCER, ACCESSORIES AND KIT CONTENTS

- measurement of temperature and other physical quantities (humidity, pressure, flow, level, speed, etc.) available through standard digital protocols and communication interfaces (RS485, Ethernet, USB)
- configurable architecture enabling using in many fields and applications (industrial, IT technologies, heating, food, energy, etc.)
- **2 universal measurement inputs** (RTD thermo-resistive, TC thermocouple, analogue 0/4÷20mA, 0÷10V, 0÷60mV, 0÷2.5kΩ) **with mathematical functions** (difference, sum, average, product, greater or lesser of the measurements) available independently for transmission and controlling alarm/control outputs
- **digital input (BIN)** for quick change of transducer operation mode: start/stop of alarm/control, manual/automatic mode for outputs, deletion of errors and STB alarms (LATCH)
- **2 on/off alarm/control** outputs (bi-state OC) with independent functionalities and control algorithms (SP setpoints defined by the parameter or taken from 1/2 measurement inputs):
 - **ON-OFF with hysteresis** (threshold characteristics for heating and cooling, band alarms within and out of range and with an offset for three-point control)
 - thermostat/controller/safety switch **STB** (alarm state open/closed, deleted with BIN input, can also be used as an **alarm memory** of LATCH type, e.g. after exceeding the minimum, maximum or band)
 - **manual mode** (open control loop) with the value of the control signal (MV) programmed by the user in the range of 0÷100%, also available for sensor failure
 - **limiting** the maximum level of the output signal (**power**)
- wide range of supply voltages (**18÷50 Vac / 13÷35 Vdc**)
- optional **RS485** serial interface, **MODBUS-RTU** protocol for reading measurements and parameters configuration
- optional **Ethernet** interface, **MODBUS-TCP** and **MQTT** protocols (for the Internet of Things **IoT/M2M**, cloud and mobile applications), the possibility to exchange measurement and configuration data via the **Internet**
- **USB** interface (micro USB connector, standard equipment, for programming parameters and viewing measurements via **MODBUS-RTU** and for updating firmware)
- automatic/constant compensation of RTD and R sensors line resistance and temperature of thermocouple cold junctions
- programmable input type, range of indications (for analogue inputs), options of alarms/control, communication, access, and other configuration parameters
- access to configuration parameters protected by a user's password or without protection
- parameter configuration via USB port, RS485 or Ethernet and ARSOFT-CFG program (for Windows 7/10/11) or user application (using Modbus-RTU and TCP communication protocols)
- **free ARSOFT-CFG** software enabling the preview of the measured values and quick configuration of single or ready sets of parameters previously saved on the computer for re-use, e.g. in other transducers of the same type (duplication of configuration)
- housing for mounting on the TS35 rail (DIN EN 60715), IP40 from the front (IP20 from the side of the connectors)
- modern technical solutions, intuitive and simple handling, **high accuracy** and long-term stability as well as resistance to interferences
- optional (in ordering method): RS485 interface and Ethernet (RJ45 connector)
- **available accessories** (you can also buy it through the online store [apar.sklep.pl](#)):
 - USB cable (A - micro B) for connection to a computer, length 1.5 m
 - USB to RS485 converter (with galvanic separation)

▪ **kit contents:**

- transducer and user manual and warranty card



ATTENTION:

- before starting work with the transducer, read this manual and correctly perform mechanical, electrical installation and parameter configuration in accordance with Chapters 5, 6 and 8 (naming of the parameters were adopted according to the principle: index from Table 8: name, e.g. 0: **inP1**),
- **by default** the transducer is configured to measure temperature from Pt100 sensors, control/alarm of the heating type (ON-OFF algorithm with hysteresis) and a set emergency state for OC outputs, description in chapter 9.

4. TECHNICAL DATA

Universal inputs (2 programmable - parameters <u>0/9: inP1/2</u> , 17 types, 18 bit A/C processing), measuring ranges			
- Pt100 (RTD, 3- or 2-wire)	-200 ÷ 850 °C	- R (TC, PtRh13-Pt) thermocouple	-40 ÷ 1600 °C
- Ni100 (RTD, 3- or 2-wire)	-50 ÷ 170 °C	- T (TC, Cu-CuNi) thermocouple	-25 ÷ 350 °C
- Pt500 (RTD, 3- or 2-wire)	-200 ÷ 620 °C	- E (TC, NiCr-CuNi) thermocouple	-25 ÷ 820 °C
- Pt1000 (RTD, 3- or 2-wire)	-200 ÷ 520 °C	- N (TC, NiCrSi-NiSi) thermocouple	-35 ÷ 1300 °C
- J (TC, Fe-CuNi) thermocouple	-40 ÷ 800 °C	- current (mA, R _{we} = 50 Ω)	0/4 ÷ 20 mA
- K (TC, NiCr-NiAl) thermocouple	-40 ÷ 1200 °C	- voltage (V, R _{we} = 110 kΩ)	0 ÷ 10 V
- S (TC, PtRh10-Pt) thermocouple	-40 ÷ 1600 °C	- voltage (mV, R _{we} > 2 MΩ)	0 ÷ 60 mV
- B (TC, PtRh30PtRh6) thermocouple	300 ÷ 1800 °C	- resistive (R, 3-w or 2-w)	0 ÷ 2500 Ω
Response time for measurements (10 ÷ 90%)		0.5 ÷ 5 s (programmable), default ~1 s	
Leads resistance (RTD, Ω)		R _d < 25 Ω (for each line), auto or fixed compensation	
Resistance input current (RTD, Ω)		400 µA (Pt100, Ni100), 200 µA (Pt500, Pt1000, 2500 Ω)	
Processing errors (at an ambient temperature of 25°C):			
- basic	- for RTD, mA, V, mV, Ω	0.1% of the measuring range ± 1 digit	
	- for thermocouples	0.2% of the measuring range ± 1 digit	
- additional for thermocouples		<2 °C (temperature of cold ends)	
- additional caused by ambient temperature changes		<0.004 % of input range /°C	
Resolution of the measured temperature		0.1°C or 1°C, programmable (with parameters <u>3/12: dot1/2</u>)	
Indications range (resolution for analog inputs)		maximum -1999 ÷ 9999, programmable	
Decimal point position for analog inputs		programmable (<u>dot1/2</u>) in the range of 0 ÷ 3, i.e. 0 ÷ 0.000	
BIN digital input (contact or voltage <24V)		bi-state, active level: short-circuit or <0.8V	
OC bi-state outputs (open collector, 2 independent)		transistor of NPN OC type, 11Vdc, current < 35mA	
Power supply (Uzas)	18 ÷ 50 Vdc, <2W (DC voltage)	13 ÷ 35 Vac, <2VA (AC voltage, 50/60Hz)	
Communication interfaces (independent, can be used simultaneously)	- USB (type B micro connector, communication with a computer), standard - RS485 (separated), option - Ethernet (separated, RJ45 connector with LINK-UP and TX/RX LEDs), standard	drivers for Windows 7/10/11 (virtual COM serial port, MODBUS-RTU protocol, Slave) MODBUS-RTU protocol, Slave, speed 2.4 ÷ 115.2 kb/s, programmable character format (<u>8N1</u> , 8E1, 8o1, 8N2) 10base-T option, TCP/IP protocols: MODBUS-TCP (Server), MQTT (client, v.3.1.1), DHCP (client), ICMP (ping)	
Led signalling (A1, A2, Rx/Tx/Stat)	3 LEDs: OC1/2 output status and operation/communication status indication		
Rated operating conditions	0 ÷ 50°C, <90 %RH, no water vapour condensation, working environment: air and neutral gases, dust-free		
Protection class	From the front IP40, IP20 from the side of the connectors		
Electromagnetic Compatibility (EMC)	resistance: according to PN-EN 61000-6-2 standard, emissivity: PN-EN 61000-6-4		
Safety requirements according to PN-EN 61010-1 norm	installation category: II	pollution degree: 2	
	voltage to ground: 300 V for the supply circuit, 50 V for the remaining input and output circuits and communication interfaces		
	insulation resistance > 20 MΩ	altitude above the sea level <2000 m	

5. HOUSING DIMENSIONS AND ASSEMBLY DATA

Housing and material	for the rail, PC/ABS self-extinguishing
Size and weight	79 x 107 x 35 mm (W x H x D), weight ~100g
Mounting	on the TS35 rail (DIN EN 60715)
Cable cross sections	1.5mm ²

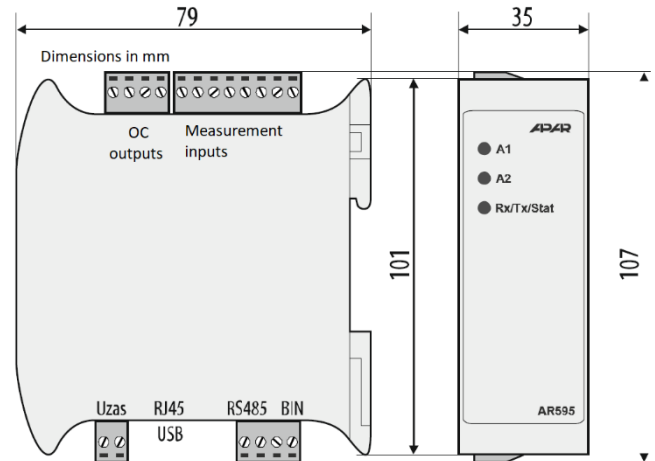

Fig. 5. Housing Dimensions and arrangement of connectors and LEDs

6. DESCRIPTION OF CLAMPING RAILS AND ELECTRICAL CONNECTIONS AND LEDS

Table 6. Description of clamping rails and LEDs on the front panel

Clamps / Connectors / LED	Description
IN1-IN2-IN3	Pt100, Ni100, Pt500, Pt1000 inputs, resistive, (2- and 3-wire)
IN2-IN3	TC thermocouple (J, K, S, B, R, T, E, N) and voltage inputs 0 ÷ 60mV
IN3-GND (12)	current inputs 0/4 ÷ 20mA
IN4-GND (12)	voltage inputs 0 ÷ 10V
10, 11 and A1, A2 (Fig.5) 9	NPN transistor alarm outputs, open collector (OC) with status indication (LED) +11V output (against 12-GND) for OC1, OC2 outputs (to supply loads, e.g. SSR)
13-14 (12)	functional BIN input (contact or voltage <24V, chapter 7)
15-16 (option)	RS485 serial interface (MODBUS-RTU protocol, slave), chapter 11
17-18	Uzas supply input (18 ÷ 50 Vdc, 13 ÷ 35 Vac)
USB (micro type B)	USB serial interface for cooperation with a computer (MODBUS-RTU), chapter 11
RJ45 (option)	Ethernet serial interface (MODBUS-TCP, MQTT protocols, etc.), chapter 11
Rx/Tx/Stat (Fig.5)	LED signaling of USB, RS485 or Ethernet transmission and operating status (flashing at start-up)

a) clamping rails and connectors

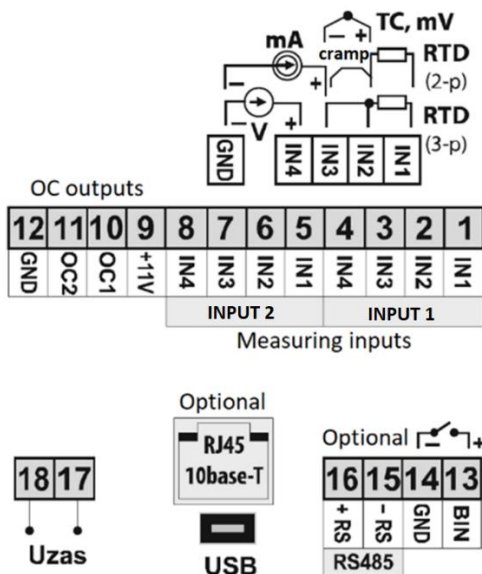

b) galvanic separation of circuits

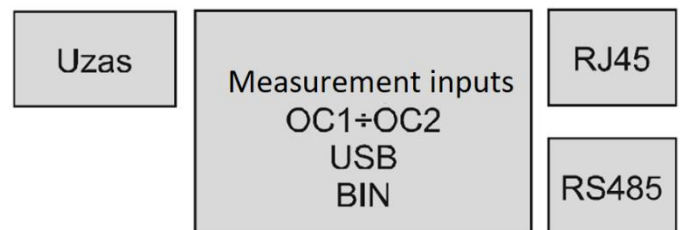

c) connection of SSR relay

to the OC output of the transducer

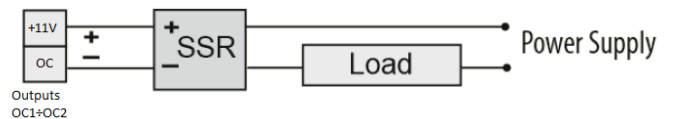

7. FUNCTIONAL BIN INPUT

The **BIN** binary (digital) input is used to quickly run the programmed function (with parameter 37: **Funb**, described in [chapter 8](#)). It works with a bistable signal, i.e. the supplied signal (voltage or switch) must be permanent (on/off type, active level: short circuit or < 0.8V). It is possible to start or stop the function at any time during the operation of the transducer.

8. SETTING OF CONFIGURATION PARAMETERS

All the configuration parameters of the transducer are stored in the non-volatile internal memory.

When the device is switched on for the first time, the diodes A1 and A2 (and the outputs OC1 and OC2) may show an emergency indication related to the lack of a sensor or attached other than factory-programmed one ([chapter 10](#)). In such case, connect the appropriate sensor or analog signal, or perform the programming of the configuration.

Configuration of parameters is possible remotely via one of the available communication ports (**USB** - recommended for the first programming, **RS485** or **Ethernet**) and the **ARSOFT-CFG** computer program ([chapter 11](#)):

- connect the transducer to a computer port, start and configure the ARSOFT-CFG application,
- after establishing the connection, the program displays the current measurement, the **Rx/Tx** led signals the transmission (Fig.5)
- setting and viewing device parameters is available in the parameter configuration window
- new parameter values must be confirmed with the **Approve changes** key
- the current configuration can be saved in a file or set using values read from a file



NOTICE:

- before disconnecting the device from the computer, use the **Disconnect the device** (ARSOFT-CFG) key
- in the event of no response:
 - check the settings in **Edit of configuration** (*Connection type, COM Port, MODBUS address of the device, etc.*)
 - for USB, check whether the drivers for the serial port in the computer have been correctly installed (see [section 11](#))
 - disconnect for a few seconds and reconnect the transducer or the RS485 converter to the USB port of the computer
- restart the ARSOFT-CFG and/or the computer





If a discrepancy of indications with the actual value of the input signal is found, it is possible to tune the zero and sensitivity to a given sensor: parameters 7/16: **cAo1/2** (zero) and 8/17: **cAG1/2** (sensitivity).





Use the default values in ARSOFT-CFG to reset the company's configuration parameters. If the access password (42: **pass**) is lost, you can use the procedure of restoring the default password. For this purpose, at the time of power start, the BIN input should be turned on for a short while (short-circuit/open during the start sequence indicated by the flashing of the Rx/Tx/Stat led).

Table 8. List of configuration parameters

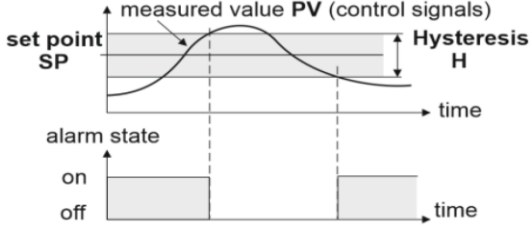
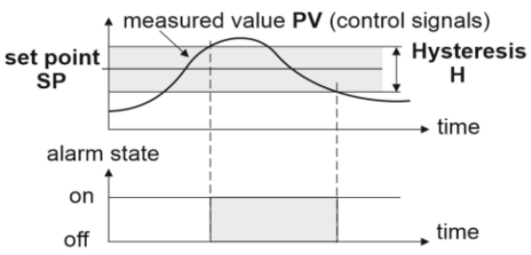
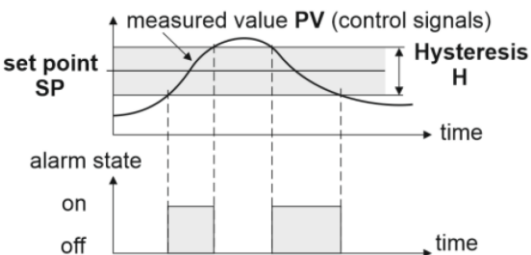
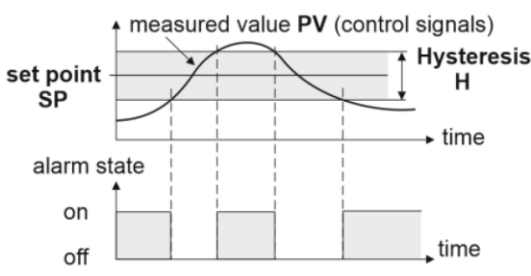
Parameter (index: name)	Value and range of variability of the parameter (value: name) and description	Default	
I. CONFIGURATION OF MEASUREMENT INPUTS (inC1/2), in 2 groups Input1/2 there are identical sets of parameters with different indexes and numbering in names			
0/9: inP1/inP2 type of measurement input	0: Pt100 sensor (RTD, -200 ÷ 850°C) 2: Pt500 sensor (RTD, -200 ÷ 620°C) 4: tc-J thermocouple of type J (-40 ÷ 800°C) 6: tc-S thermocouple of type S (-40 ÷ 1600°C) 8: tc-R thermocouple of type R (-40 ÷ 1600°C) 10: tc-E thermocouple of type E (-25 ÷ 820°C) 12/13: 4 ÷ 20 mA/0 ÷ 20 mA current signals 14/15: 0 ÷ 10 V/0 ÷ 60 mV voltage signals 16: resistance signal 0 ÷ 2500 Ω	1: Ni100 sensor (RTD, -50 ÷ 170°C) 3: Pt1000 sensor (RTD, -200 ÷ 520°C) 5: tc-K thermocouple of type K (-40 ÷ 1200°C) 7: tc-B thermocouple of type B (300 ÷ 1800°C) 9: tc-T thermocouple of type T (-25 ÷ 350°C) 11: tc-N thermocouple of type N (-35 ÷ 1300°C)	Pt100
1/10: Lir1/2 line resistance	0.00 ÷ 50.00 Ω total line resistance for 2-wire RTD and 2500Ω sensors (1)	0.00 Ω	
2/11: cJt1/2 temperature of cold ends of thermocouples	0.0 (Auto) 0.1 ÷ 60.0 °C automatic or constant temperature compensation of the reference junction of thermocouples, Auto = 0.0 °C	0.0 (Auto)	
3/12: dot1/2 dot position/resolution (for ARSOFT-CFG and MQTT)	0 / 1 no dot / 0,0 (2) or 1/0,1°C resolution for temperature 2 / 3 0.00/ 0.000 (2)	1 (0.1°C)	
4/13: irL1/2 bottom of the indication range (beginning of the scale)	-1999 ÷ 9999 (2) scale start for 0/4mA, 0V, 0Ω input	0,0 °C	
5/14: irH1/2 top of indication range (end of scale)	-1999 ÷ 9999 (2) end of scale for inputs 20mA, 10V, 60mV, 2.5kΩ	100.0 °C	
6/15: Fil1/2 filtration (3)	1 ÷ 20 digital filtering degree (response time)	3 (~1s)	
7/16: cAo1/2 zero calibration	zero offset for measurements: -100.0 ÷ 100.0 °C or -1000 ÷ 1000 units (2)	0,0 °C	
8/17: cAG1/2 gain	85,0 ÷ 115,0% slope calibration (sensitivity) for measurements	100,0%	

II. CONFIGURATION OF OUTPUTS 1 and 2 (out1/2), in 2 groups there are identical sets of parameters differing in indexes and numbering in names (and possibly in the range of variability), description in [chapter 9](#)

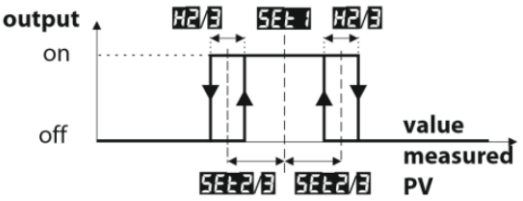
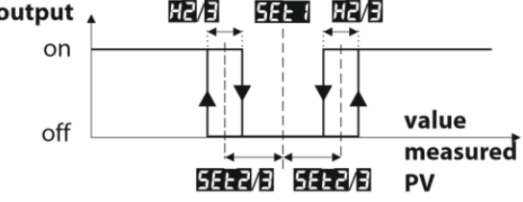
<p>18/27: coS1/2 PV control signal for output (input assignment) 19: ctY1 control algorithm 28: ctY2 for output 2 (out2) Note (for value 4/5): if a BIN with start/stop function of outputs was used to clear the STB alarm (LATCH), start is always needed to <u>restart the STB and adjust it</u></p>	<p>0: inP1 = input measurement 1, 1: inP2 = input measurement 2, 2: Subt = measurement difference 1-2, 3: Addi = sum of measurements 1+2, 4: AvrG = average value of measurements 1 and 2, 5: LArG = larger of measurements 1 and 2, 6: SMAL = smaller of measurements 1 and 2, 7: MuLt = product of measurements 1*2 0: oFF 1: onof 2: hAnd M (manual)</p>	<p>output permanently disabled enable/disable (ON-OFF) with hysteresis manual (with setpoint set with parameter 39: HSEt and impulse period of output OC1/2, 25/34: PEr1/2)</p> <p>STB safety thermostat (memory alarm, LATCH), open/closed emergency status (cleared from BIN input, chapter 7)</p>	<p>inP1/2 onof</p>
<p>20: Fun1 type of regulation/alarm 29: Fun2 for output 2 (out2) 1. parameters apply to control algorithms: ON-OFF with hysteresis and STB (LATCH)</p>	<p>0: indH heating / reversed  (activated below SP) 1: dirC cooling / direct  (activated above SP) 2: inbA inband alarm  (activated in band) 3: oubA out-of-band alarm  (disabled in band)</p>	 <p>Fig. 8.1. Characteristics of the heating type (for ON-OFF)</p>  <p>Fig. 8.2. Characteristics of the cooling type (for ON-OFF)</p>  <p>Fig. 8.3. Characteristics of the in band alarm (ON-OFF)</p>  <p>Fig. 8.4. Out of band alarm characteristics (ON-OFF)</p>	<p>indH</p>

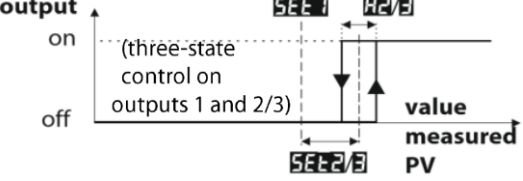
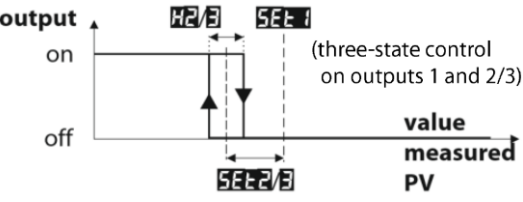
<p>2. characteristics 4 ÷ 7 (i.e. against SP1) are only available for Fun2 parameters (output 2)</p>	<p>4: rbon alarm in band ± SP2 around SP1- setpoint of output 1</p>  (activated in band) <p>5: rboF alarm out of band ± SP2 around SP1- setpoint of output 1</p>  (disabled in band)	 <p>Fig. 8.5. Characteristic <i>in band</i> in relation to SP1</p>  <p>Fig. 8.6. Characteristic <i>out of band</i> in relation to SP1</p>										
<p>SP1/2- setpoints for outputs 1/2 selected with parameters 21/30: SES1/2, i.e. 22/31: SEt1/2 or input measurement)</p>	<p>6: dEoF disabled below $SP = SP1 + SP2$</p>  (activated above SP) <p>7: dEon activated below $SP = SP1 + SP2$</p>  (activated below SP)	 <p>Fig. 8.7. Deviation from SP1 (for $SP2 > 0$)</p>  <p>Fig. 8.8. Deviation from SP1 ($SP2 < 0$)</p>										
<p>21/30: SES1/2 setpoint selection SP (1/2) 22/31: SEt1/2 value SP1/2 23/32: H1/2 hysteresis H 24/33: oPF1/2 power limit (available power) 25/34: PEr1/2 output pulse period 26/35: Fto1/2 output emergency state</p>	<p>0: inP1 = input 1 measurement, 1: inP2 = input 2 measurement, 2: SEtP = fixed setpoint SP defined by parameter 22/31: SEt1/2 SP setpoint for alarm / regulation, $-199.9 \div 1800.0$ °C or $-1999 \div 9999$ (2) hysteresis, $0.0 \div 999.9$ °C or $0 \div 9999$ units (2) 0 ÷ 100%, maximum control signal/power level, 1% step (4) 0 ÷ 360s, applies to power limitation and manual mode for OC1/2 outputs (pulse with 0 ÷ 100% fill factor) for missing/damaged sensor/signal/input or out of measuring range: 0: noCh = unchanged, 1: oFF = disabled, 2: on = enabled, 3: hAnd = manual mode with set output signal level (with parameter 39: HSEt)</p>	<p>1800.0 °C 1.0 °C 100 % 1 sec. hAnd</p>										
<p>VI. ACCESS OPTIONS AND OTHER CONFIGURATION PARAMETERS (othE submenu)</p>												
<p>37: Funb BIN input function (description in chapter 7) 39: HSEt control signal setpoint (MV) for outputs in manual mode</p>	<table border="1"> <tr> <td>0: nonE</td> <td>inactive</td> </tr> <tr> <td>1: hd1U 2: hd2U</td> <td>unconditional manual mode for output 1/2 with output signal level (MV) set with parameter 39: HSEt M</td> </tr> <tr> <td>3: cLEA</td> <td>clearing the alarm memory (LATCH) of the STB safety switch</td> </tr> <tr> <td>4: SPSt</td> <td>start/stop of operation of outputs 1/2 with function 3: cLEA, active input = start</td> </tr> <tr> <td>M0 ÷ 100 %</td> <td>applies to all outputs (1, 2), 100% means the maximum available output power (set with parameters 24/33: oPF1/2), step every 1% (4)</td> </tr> </table>	0: nonE	inactive	1: hd1U 2: hd2U	unconditional manual mode for output 1/2 with output signal level (MV) set with parameter 39: HSEt M	3: cLEA	clearing the alarm memory (LATCH) of the STB safety switch	4: SPSt	start/stop of operation of outputs 1/2 with function 3: cLEA , active input = start	M0 ÷ 100 %	applies to all outputs (1, 2), 100% means the maximum available output power (set with parameters 24/33: oPF1/2), step every 1% (4)	<p>nonE 50,0 %</p>
0: nonE	inactive											
1: hd1U 2: hd2U	unconditional manual mode for output 1/2 with output signal level (MV) set with parameter 39: HSEt M											
3: cLEA	clearing the alarm memory (LATCH) of the STB safety switch											
4: SPSt	start/stop of operation of outputs 1/2 with function 3: cLEA , active input = start											
M0 ÷ 100 %	applies to all outputs (1, 2), 100% means the maximum available output power (set with parameters 24/33: oPF1/2), step every 1% (4)											
<p>41: PProt protection of configuration with an access password</p>	<p>0: oFF = entering the remote configuration menu via ARSOFT-CFG is <u>not</u> password protected, 1: on = remote configuration <u>is</u> password protected</p>	<p>on</p>										
<p>42: Pass access password</p>	<p>0 ÷ 9999 password for entering the configuration menu and for the MQTT (chapter 11.1)</p>	<p>1111</p>										

VII. DISPLAY OPTIONS (diSP submenu)		
44: Unit of measurement for the MQTT protocol	0: none, 1: m, 2: mA, 3: A, 4: mV, 5: V, 6: °C, 7: %RH, 8: %, 9: °C %RH, 10: k, 11: Pa, 12: kPa	°C
VIII. COMMUNICATION OPTIONS FOR RS485 AND ETHERNET, submenu trAn, description in chapters 11 ÷ 11.5		
47: r4br rate for RS485	baud rate kbit/s, 0: 2.4, 1: 4.8, 2: 9.6, 3: 19.2, 4: 38.4, 5: 57.6, 6: 115.2	19.2 kbit/s
48: r4cF RS485 character format	selection of parity and alloy bits, 0: 8N1 (none), 1: 8E1 (even), 2: 8O1 (odd), 3: 8N2	8N1
49: Addr MODBUS-RTU address	1 ÷ 247 device address for RS485 and suffix (suffix) for the name, (5)	1
50: EtMo Ethernet interface operation mode (MAC hardware <u>address</u> available from ARSOFT-CFG and MODBUS-RTU/TCP)	0: oFF Ethernet always <u>off</u> (recommended when not in use) 1: Auto DHCP client <u>enabled</u> , network parameters (from 51: EIP3 to 62: EGA0 , i.e. device IP address, mask and gateway) are set <u>automatically</u> 2: Stat DHCP client <u>disabled</u> , network parameters are set <u>manually</u>	oFF
51 ÷ 54: EiP3/2/1/0 IP address	0 ÷ 255 device's IPv4 address in the local network (Ethernet), 4 consecutive octets	192.168.0.200
55 ÷ 58: ESu3/2/1/0 IP mask	0 ÷ 255 mask of the IPv4 address in the local network (Ethernet), 4 consecutive octets	255.255.255.0
59 ÷ 62: EGA3/2/1/0 IP gateway	0 ÷ 255 router's IPv4 address in the local network (Ethernet), 4 consecutive octets	192.168.0.1
63: EtcP MODBUS-TCP port	1 ÷ 9999 TCP port number for the MODBUS-TCP protocol (also for ARSOFT-CFG) 0: oFF MQTT protocol <u>disabled</u> (recommended when not used)	502
64: MqMo operating mode and type of published MQTT messages (Ethernet) (detailed description of MQTT communication, chapter 11.1)	1: inP1 MQTT protocol enabled, only measurement 1 (PV1) in the publication, e.g. "4.5" 2: inP2 MQTT protocol enabled, only measurement 2 (PV2) in the publication, e.g. „9.9" 3: Subt MQTT protocol enabled, in the content of the publication only the measurement difference 1-2 4: Addi MQTT protocol enabled, in the content of the publication only the sum of measurements 1+2 5: AvrG MQTT enabled, in the content of the publication only the average value of measurements 1 and 2 6: LArG MQTT protocol enabled, in the content of the publication, the greater value of measurements 1 and 2 7: SMAL MQTT protocol enabled, in the content of the publication the smaller value of measurements 1 and 2 8: MuLt MQTT protocol enabled, in the content of the publication only the sum of measurements 1*2 9: in12 MQTT enabled, device name included, measurements 1 and 2, unit, (5) 10: FULL MQTT enabled, device name included, measurements 1 and 2, unit, (5) publication of the full operating status (PV1/2, MV1/MV2, BIN, etc.)	oFF
65 ÷ 68: Mqb3 ÷ 0 MQTT address	0 ÷ 255 IPv4 address of the MQTT broker (Ethernet), 4 consecutive octets	192.168.0.10
69: MqtP MQTT broker port	1 ÷ 9999 MQTT broker TCP port number	1883
70: MqPE publication period MQTT	1 ÷ 3600 s interval of sending messages to the MQTT broker (Ethernet)	10 sec.
71: MqtL subject level MQTT	1 ÷ 9999 numeric suffix for MQTT publication subject name (APAR/ MqtL)	APAR/1

Notes: (1) – for 3-wire sensors, the **Lir1/2** parameter must be 0.00 Ω (automatic compensation),

(2) - applies to analog inputs (mA, V, mV, Ω),

(3) – for **Fil1/2 = 1** the response time is 0.5 seconds, for **Fil1/2 = 20** at least 5 seconds. Higher degree of filtration stands for the more "smoothed" measured value and the longer response time recommended for measurements of turbulent nature (e.g. water temperature in the boiler),

(4) - for binary outputs (OC1/2) large rounding can occur, 1% is possible only for the pulse period (parameters 25/34: **PEr1/2**) greater than 20s, for 4s it is 5%, for 2s 10%, for 1s up to 20%.



The control signal **MV=100%** means the maximum available output power (limited by 24/33: **oPF1/2**),

(5) – device name is created according to the template: AR595_**Addr** (e.g. "AR595_1" for 49: **Addr = 1**). It is used in the content of the published MQTT message ([chapter 11.1](#)) and by the DHCP client (when 50: **EtMo = Auto**).

9. OUTPUT CONFIGURATION PARAMETERS

Programmable architecture of the transducer allows its use in many fields and applications. Before starting the operation of the device, set the parameters to individual needs (such as control algorithms 19/28: **ctY1/2**, types of regulation/alarms 20/29: **Fun1/2**, setpoints 22/31: **Set1/2** and other described in [Table 8, chapter 8](#)).

The default (factory) configuration is as follows: outputs 1, 2 in regulation/alarm mode of heating type (ON-OFF algorithm with hysteresis) and set emergency state for OC outputs, [Table 8](#) column *company* settings. The above configuration allows to signal the presence of power supply and the correctness of measurements (outputs and diodes 1/2 permanently enabled) and to signal the emergency status of measurement inputs (flashing of diodes A1/2 and pulsing of outputs OC1/2).

10. SIGNALING OF MEASUREMENT ERRORS

1. The transducer detects the following measurement errors (inputs failure states):

- exceeding the measuring range of the sensor/signal from above (High) or from below (Low),
- incorrectly connected or sensor/signal different than the one set in the configuration ([chapter 8, parameter 0/9: inP1/2](#)),
- sensor/measurement signal missing or input damaged (----).

2. Possible ways of signaling measurement errors:

- pulsing of OC1/2 outputs and A1/2 LEDs with a set period and filling (through parameters 25/34: **PEr1/2** and 39: **HSEt** when parameter 26/35: **Fto1/2 = hAnd**) or switching on/off outputs 1/2 permanently (when 26/35: **Fto1/2 = on** or **oFF**),
- measurement value equal to -19999 (Low), 19999 (High) or 31999 (----), Table 11.5, registry address = 0x10 ÷ 0x16.

11. SERIAL COMMUNICATION, AVAILABLE SOFTWARE AND USB DRIVERS

Communication with the transducer is possible through each of the available serial interfaces (independently, i.e. RS485, Ethernet and USB) and can be used in various applications, e.g.:

- remote monitoring and recording of current measurements as well as control of the operating status and control algorithms for outputs,
- quick configuration of parameters, including copying settings to other transducers of the same type.

In order to establish long-distance communication, a connection should be made in the **RS485** standard (MODBUS-RTU protocol, [chapters 11.3 and 11.4](#)) or **Ethernet** using the MODBUS-TCP ([chapter 11.2](#)) and MQTT protocols ([chapter 11.1](#)).

When the transducer (or RS485 converter) is connected to the computer for the first time via the USB port, the system will start the process of automatic installation of the COM serial port driver (from the [Windows Update website](#)). Alternatively, you can manually indicate the location of the driver on the computer's disk from the **Device Manager**, following the instructions of the installation wizard (for the transducer, select the "AR2xx /..." drivers downloaded from the [www.apar.pl/en](#) website or from the ARSOFT-CFG program installation folder, by default „C:\Program Files (x86)\ARSOFT\Drivers\AR2xx...“).

The following applications are available (for Windows 7/10/11 operating systems, downloadable from [www.apar.pl/en/download/software](#) or optionally from a CD or e-mail from the Sales Department):

Name	Description of the program
ARSOFT-CFG (free)	<ul style="list-style-type: none">- displaying current measurement data from the connected Apar device- configuration of the measurement input type, indication range, adjustment options, alarms, display, communication, access, etc. (chapter 8)- creating the file with the extension "cfg" on a disk containing the current configuration of parameters for reuse (copying of configuration)
APSystem-PC (paid)	<ul style="list-style-type: none">- display and recording of current measurements from many devices (via MODBUS-RTU/TCP/ASCII)- visual and audible alarms, e-mail alerts, event reporting, etc.

Detailed descriptions of the above mentioned applications can be found in the installation folders.



ATTENTION:

Before establishing a connection via **RS485**, make sure that the parameters of the device (47: **r4br**, 48: **r4cF** and 49: **Addr**) comply with the settings of the computer program. Moreover, set the number of the COM serial port used in the program options (for the RS485 converter assigned by the system during the installation of drivers).

Depending on the protocol used, the connection via the **Internet** requires the known public IP address of the broker for the MQTT protocol and the network IP address in the case of MODBUS-TCP (to facilitate access to the network with a variable public IP address, you can start the DDNS service, e.g. in a router). **The selection of network parameters in the transducer and the configuration of the router** (including e.g. port redirection for MODBUS-TCP, port forwarding) **should be entrusted to a qualified person (network administrator)**. In addition, pay attention that the firewall does not block the ports and applications used (e.g. ARSOFT-CFG). The unique MAC (**EUI-48**) hardware address of the transducer Ethernet interface is available in ARSOFT-CFG (Parameters-> Communication options) and in the MODBUS-RTU/TCP protocol [register map](#).

The easiest way to test the correctness of the transducer's operation in the LAN network is to set the Ethernet interface in the automatic mode (parameter 50: **EtMo = Auto**), and then (with the IP address assigned by the DHCP server read from the device) establish connection with the ARSOFT -CFG program or execute the *ping* command from the computer's command line (and optionally *arp -a* for Windows or *arp-scan* for Linux, where we will also get the MAC address).

11.1. MQTT PROTOCOL

Popular in IoT/M2M (Internet of Things) applications, the MQTT protocol is a lightweight data transmission protocol based on the publication/subscription pattern (to/from the server). Using the protocol requires a correctly configured Ethernet network interface and MQTT parameters ([chapter 8, Table 8, point VIII](#)), as well as access to a broker (server) with a fixed numeric IP address (the converter does not support the DNS protocol - text domain names). The MQTT broker can be started independently (eg. Mosquitto) or use the ones available on the Internet (paid or free, e.g. EMQX). Knowing the name of the broker's website, you can check its IP address, e.g. with the *ping* command (from the computer's command line). To read (subscribe) the messages published

by the transducer from the broker, you can use your own solutions or one of the many applications available on the Internet (such as the free and easy-to-use "MQTT Dash" for Android). Establishing a connection with the broker may take some time (usually <1,5 minutes, restarting the device may speed up this process). The current status of the transducer's connection with the MQTT broker is available from the MODBUS-TCP/RTU protocols (register at 31: *Ethernet connection status, chapter 11.5*).

Parameter 64: **MqMo** (description in [Table 8](#)) is responsible for selecting the content of messages sent cyclically to the MQTT broker. Sample content for the most extensive option (when 64: **MqMo** = **FULL**, maximum size 90B): "AR595_1;PV1=36.6;PV2= 21.5;°C; MV1=100 %;MV2=100 %;cstat=0x0000;BIN=0" (AR595_Addr = device name; PV1-2= measurement values 1 and 2;unit;MV1= control signal value of output 1;MV2 for output 2; cstat = operating status of control algorithms, description in [chapter 11.5](#); BIN= binary input state, 0=shorted, i.e. active).

In addition, for optional connection authorization, the following fields are set in the MQTT package: customer ID (created according to the "aparMAC" template, where MAC is the hardware address of the EUI-48 transducer, e.g. "aparFCC23D21C54A") and user name (as "aparPass", the last 2 digits of parameter 42: **Pass**, e.g. "apar11") and password (parameter 42: **Pass**).

Protocol parameters useful for advanced needs: version 3.1.1, QOS=0, retain=1, keep alive=0 (off).

In the event of frequent disconnection with the broker, check the reliability of the network/internet connection (switch), test the possible impact of the message publication period (extend, recommended > 5s, parameter 70: **MqPE**), as well as MODBUS-TCP communication (temporarily stop if in use).

11.2. MODBUS-TCP SERIAL TRANSMISSION PROTOCOL

The MODBUS-TCP protocol is available for the Ethernet (RJ45) interface and uses the TCP/IP transport layer. Parameters used by this service, such as the TCP port number, are described in [chapter 8, Table 8, point VIII](#).

The timeout for the MODBUS-TCP transmission, after which the open but unused port is closed, is 60s.

Available functions: READ - 3 lub 4, WRITE - 6

Table 11.2.1. MODBUS-TCP protocol request frame format for the READ and WRITE functions (frame length - 12B)

MODBUS protocol header (7 bytes)			Function code (READ or WRITE)	register address from Table 11.5 (chapter 11.5)	number of registers to read (1 ÷ 13) or value of a register to write
Transaction and protocol identifiers	Length field (value = 6)	Unit ID			
4 bytes	2 bytes	1 byte	1 byte	2 bytes (HB-LB)	2 bytes (HB-LB)

Example 11.2.1. Reading a register with address 0: 0x00 - 0x00 - 0x00 - 0x00 - 0x00 - 0x06 - 0xFF - 0x04 - 0x0000 - 0x0001

Table 11.2.2. Response frame format for the READ function (minimum frame length - 11 bytes):

MODBUS protocol header (7 bytes)			Function code (READ)	number of bytes in the data field (2 ÷ 26)	data field - register value (2B)
Transaction and protocol identifiers	Length field (max 29)	Unit ID			
4 bytes	2 bytes	1 byte	1 byte	1 byte	2 ÷ 26 bytes (HB-LB)

Example 11.2.2. The response frame for the register value equal to 0:

0x00 - 0x00 - 0x00 - 0x00 - 0x00 - 0x05 - 0xFF - 0x04 - 0x01 - 0x0000

Table 11.2.3. Response frame format for the WRITE function (frame length - 12 bytes)

copy of the query frame for the WRITE function (Table 11.2.1)

The error codes are the same as for the MODBUS-RTU protocol ([Table 11.4.5](#))

Example 11.2.3. Error frame for a non-existing read register address:

0x00 - 0x00 - 0x00 - 0x00 - 0x00 - 0x05 - 0xFF - 0x84 - 0x02 - 0x0001

11.3. RS485 COMMUNICATION INTERFACE (acc. to EIA RS-485)

The installation specification for RS485 interface is as follows:

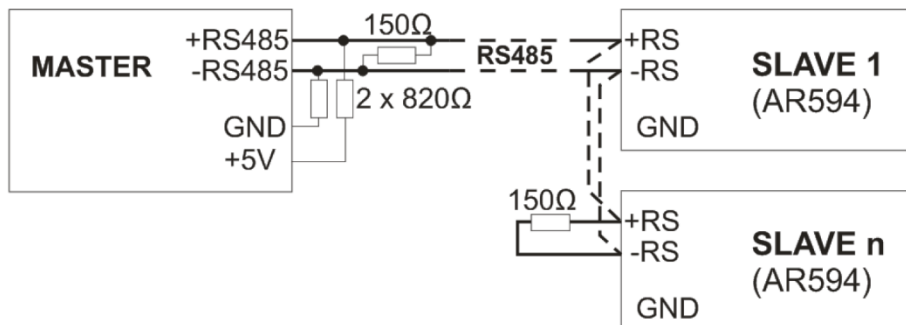

- maximum cable length – 1km (observe the installation guidelines, [chapter 2](#));
- maximum number of devices in a RS485 line: 30, in order to increase the number use RS485/RS485 amplifiers;
- termination and polarizing resistors when the MASTER is at the start of the line (Fig. 12):
 - at the start of the line - 2 x 820Ω to the ground and +5V of the MASTER and 150Ω between lines;
 - at the end of the line - 150Ω between the lines (or clamp JP1 closed, see [chapter 7](#));
- termination and polarizing resistors when the MASTER is in the center of the line:
 - at the converter - 2 x 820Ω, to the ground and +5V of the converter;
 - at both ends of the line - 150Ω between the lines (or clamps JP1 closed, see [chapter 7](#)).

Equipment from different manufacturers that form the RS485 network (e.g. RS485 converters/USB) may have integrated polarizing and terminating resistors; in such a case there is no need to use external elements.

Equipment from different manufacturers that form the RS485 network (e.g. RS485 converters/USB) may have integrated polarizing and terminating resistors; in such a case there is no need to use external elements.

When configuring the network, it is necessary to pay particular attention to the cabling installation recommendations given in [chapter 2](#).

11.4. MODBUS-RTU SERIAL TRANSMISSION PROTOCOL (SLAVE)

Baudrate and character format for RS485 and Modbus-RTU address set with parameters 47: **r4br**, 48: r4cF, 49: **Addr** ([chapter 8, Table 8, point VIII](#)).

Available functions: READ = 3 or 4, WRITE = 6. [The protocol is also available for USB.](#)

Table 11.4.1. Query frame format for the READ function (frame length - 8 bytes):

address of the device	function 4 or 3	register address to be read: from Table 11.5 (chap. 11.5)	number of read registers: 1 ÷ 13	CRC checksum
1 byte	1 byte	2 bytes (HB-LB)	2 bytes (HB-LB)	2 bytes (LB-HB)

Example 11.4.1. Reading of a register with address 0: 0x01 - 0x04 - 0x0000 - 0x0001 - 0x31CA

Table 11.4.2. Query frame format for the WRITE function (frame length - 8 bytes):

address of the device	function 6	write register address: from Table 11.5 (chap. 11.5)	write register value	CRC checksum
1 byte	1 byte	2 bytes (HB-LB)	2 bytes (HB-LB)	2 bytes (LB-HB)

Example 11.4.2. Entry in a register with address 10 (0xA) with the value 0: 0x01 - 0x06 - 0x000A - 0x0000 - 0xA9C8

Table 11.4.3. Response frame format for the READ function (minimum frame length - 7 bytes):

address of the device	function 4 or 3	number of bytes in the data field (max. 13*2=26 bytes)	data field - register value	CRC checksum
1 byte	1 byte	1 byte	2 ÷ 26 bytes (HB-LB)	2 bytes (LB-HB)

Example 11.4.3. Response frame for register value equal to 0: 0x01 - 0x04 - 0x02 - 0x0000 - 0xB930

Table 11.4.4. Reply frame format for the WRITE function (frame length - 8 bytes):

copy of the query frame for the WRITE function (Table 11.4.2)

Table 11.4.5. Special reply (errors: function field = 0x84 or 0x83 in the case of the READ function and 0x86 in the case of the WRITE function):

Error code (HB-LB in data field)	Error description
0x0001	non-existing register address
0x0002	wrong write register value
0x0003	incorrect function number

Example 11.4.5. Error frame for a non-existing read register address:

0x01 - 0x84 - 0x02 - 0x0001 - 0x5130

11.5. MAP OF DEVICE REGISTERS FOR MODBUS-RTU/TCP

Table 11.5. Map of registers for the MODBUS-RTU and MODBUS-TCP protocol (1 register = 2 bytes)

Register address HEX (DEC)	Value (HEX or DEC)	Description of register and access type (R- read only register, R/W - read and write register)	
0x00 (0)	0	not used or reserved	R
0x01 (1)	5950 ÷ 5959	device type identifier	R
0x02 (2)	100 ÷ 999	transducer firmware version	R
0x03 ÷ 0x05	0	not used or reserved	R
0x06 (6)	0 ÷ 65535	Status of algorithms and control functions and status of outputs/alarms: - status of outputs/alarms 1, 2 (bits 0, 1, 2 , bit=1= output enabled), - STB (LATCH) alarms for outputs 1, 2 (bits 3, 4 , bit=1=active), - start/stop status for BIN input (bit 15 , bit=1=start), <i>chapter 7</i>	R
0x07 (7)	0	not used or reserved	R
0x08 (8)	-100 ÷ 700	temperature of cold ends for thermocouples (resolution 0.1°C)	R
0x09 ÷ 0x0A	0 ÷ 100	MV control signal value [%] for outputs 1, 2	R
0x0B (11)	0	not used or reserved	R
0x0C (12)	0 ÷ 65535	device status: - BIN input status (bit 1 , bit=1=active input=closed), <i>chapter 7</i> , - presence of Ethernet and RS485 modules (bits 4, 5 , bit=1=available), - USB connection status (bit 8 , bit=1=connected),	R
0x0D ÷ 0x0F	0	not used or reserved	R
0x10 ÷ 0x17	-32768 ÷ 32767	current measured values (in order: input 1, input 2, measurement difference 1-2, sum of measurements 1+2, average value of measurements 1 and 2, greater value of measurements 1 and 2, lower value of measurements 1 and 2, product of measurements 1*2), in code U2 (16-bit), without comma, (for thermometric inputs, resolution 0.1°C)	
0x18 ÷ 0x1E	0	not used or reserved	R
0x1F (31)	0 ÷ 65535	connection status of the Ethernet interface and the MODBUS-RTU and MQTT protocols: - LAN connection status, link-up (bit 0 , bit=1=connected), - connection with the MQTT broker status (bits 1, 2 , bit1=bit2=1=connected), - TCP port status for MODBUS-TCP (bits 6, 7, 8 , bit6=bit7=1=connected),	R
0x20 ÷ 0x22	0 ÷ 65535	unique MAC hardware address of the Ethernet interface (EUI-48)	R
Configuration parameters (the collective list of parameters can be found in <i>chapter 8, Table 8</i>)			
Register (parameter) address = 35 + parameter index from <i>Table 8</i> (e.g. address=35 for parameter 0: inP1), Register (parameter) value = value from <i>Table 8</i> (e.g. 0 for 0: Pt100)			R/W

12. OWN NOTES

