

FEATURES

- Low input offset voltage 150 μV max
- Low offset voltage drift over -55°C to $+125^{\circ}\text{C}$, 1.2 $\text{pV}/^{\circ}\text{C}$ max
- Low supply current (per amplifier) 725 μA max
- High open-loop gain 5000 V/mV min
- Input bias current 3 nA max
- Low noise voltage density 11 $\text{nV}/\sqrt{\text{Hz}}$ at 1 kHz
- Stable with large capacitive loads 10 nF typ
- Pin compatible to LM148, HA4741, RM4156, and LT1014 with improved performance
- Available in die form

GENERAL DESCRIPTION

The OP400 is the first monolithic quad operational amplifier that features OP77-type performance. Precision performance is not sacrificed with the OP400 to obtain the space and cost savings offered by quad amplifiers.

The OP400 features an extremely low input offset voltage of less than 150 μV with a drift of under 1.2 $\mu\text{V}/^{\circ}\text{C}$, guaranteed over the full military temperature range. Open-loop gain of the OP400 is over 5,000,000 into a 10 $\text{k}\Omega$ load, input bias current is under 3 nA , CMR is above 120 dB , and PSRR is below 1.8 $\mu\text{V}/\text{V}$. On-chip Zener zap trimming is used to achieve the low input offset voltage of the OP400 and eliminates the need for offset nulling. The OP400 conforms to the industry-standard quad pinout which does not have null terminals.

FUNCTIONAL BLOCK DIAGRAM

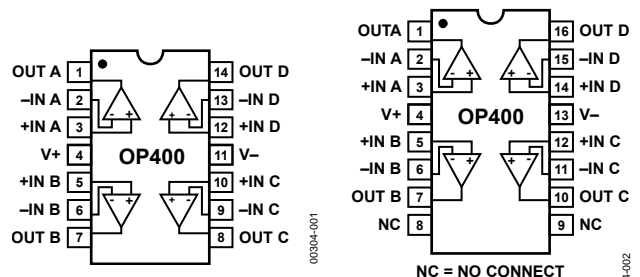

Figure 1. 14-Pin Ceramic DIP (Y-Suffix) and 14-Pin Plastic DIP (P-Suffix)

Figure 2. 16-Pin SOIC (S-Suffix)

The OP400 features low power consumption, drawing less than 725 μA per amplifier. The total current drawn by this quad amplifier is less than that of a single OP07, yet the OP400 offers significant improvements over this industry-standard op amp. Voltage noise density of the OP400 is a low 11 $\text{nV}/\sqrt{\text{Hz}}$ at 10 Hz , which is half that of most competitive devices.

The OP400 is pin compatible with the LM148, HA4741, RM4156, and LT1014 operational amplifiers and can be used to upgrade systems having these devices. The OP400 is an ideal choice for applications requiring multiple precision operational amplifiers and where low power consumption is critical.

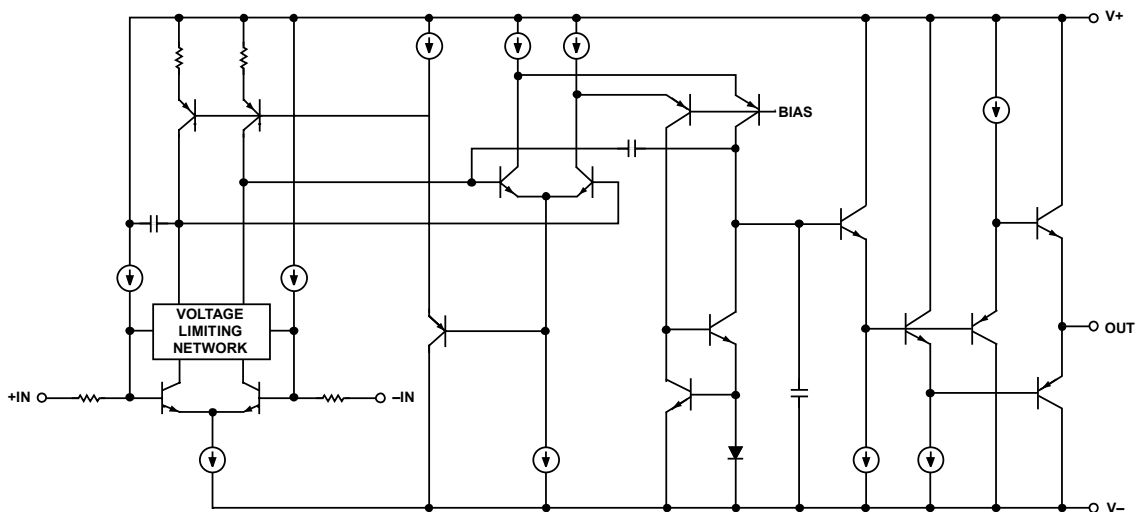

Figure 3. Simplified Schematic (One of Four Amplifiers Is Shown)

Rev. D

Information furnished by Analog Devices is believed to be accurate and reliable. However, no responsibility is assumed by Analog Devices for its use, nor for any infringements of patents or other rights of third parties that may result from its use. Specifications subject to change without notice. No license is granted by implication or otherwise under any patent or patent rights of Analog Devices. Trademarks and registered trademarks are the property of their respective owners.

TABLE OF CONTENTS

Features	1	Typical Performance Characteristics	7
Functional Block Diagram	1	Applications.....	12
General Description	1	Dual Low Power Instrumentation Amplifier	12
Revision History	2	Bipolar Current Transmitter	13
Specifications.....	3	Differential Output Instrumentation Amplifier	13
Electrical Characteristics	3	Multiple Output Tracking Voltage Reference.....	14
Absolute Maximum Ratings.....	6	Outline Dimensions	15
Thermal Resistance	6	Ordering Guide	16
ESD Caution.....	6	SMD Parts and Equivalents	16

REVISION HISTORY

3/06—Rev. C to Rev. D.

Updated Format.....	Universal
Deleted Wafer Test Limits Table	4
New Package Drawing: R-14.....	15
Updated Outline Dimensions	15
Changes to Ordering Guide	16

6/03—Rev. B to Rev. C.

Edits to Specifications	2
-------------------------------	---

10/02—Rev. A to Rev. B.

Addition of Absolute Maximum Ratings	5
Edits to Outline Dimensions.....	12

4/02—Rev. 0 to Rev. A.

Edits to Features.....	1
Edits to Ordering Information.....	1
Edits to Pin Connections.....	1
Edits to General Descriptions	1, 2
Edits to Package Type.....	2

SPECIFICATIONS

ELECTRICAL CHARACTERISTICS

@ $V_S = \pm 15\text{ V}$, $T_A = +25^\circ\text{C}$, unless otherwise noted.

Table 1.

Parameter	Symbol	Conditions	OP400A/E			OP400F			OP400G/H			Unit
			Min	Typ	Max	Min	Typ	Max	Min	Typ	Max	
INPUT CHARACTERISTICS												
Input Offset Voltage	V_{OS}			40	150		60	230		80	300	μV
Long-Term Input Voltage Stability				0.1			0.1			0.1		$\mu\text{V}/\text{mo}$
Input Offset Current	I_{OS}	$V_{CM} = 0\text{ V}$		0.1	1.0		0.1	2.0		0.1	3.5	nA
Input Bias Current	I_B	$V_{CM} = 0\text{ V}$		0.75	3.0		0.75	6.0		0.75	7.0	nA
Input Noise Voltage	$e_{n\text{ p-p}}$	0.1 Hz to 10 Hz		0.5			0.5			0.5		$\mu\text{V p-p}$
Input Resistance Differential Mode	R_{IN}			10			10			10		$\text{M}\Omega$
Input Resistance Common Mode	R_{INCM}			200			200			200		$\text{G}\Omega$
Large Signal Voltage Gain	A_{VO}	$V_O = \pm 10\text{ V}$ $R_L = 10\text{ k}\Omega$ $R_L = 2\text{ k}\Omega$		5000	12,000		3000	7000		3000	7000	V/mV
				2000	3500		1500	3000		1500	3000	V/mV
				± 12	± 13		± 12	± 13		± 12	± 13	V
Input Voltage Range ¹	IVR		± 12	± 13		± 12	± 13		± 12	± 13	V	
Common-Mode Rejection	CMR	$V_{CM} = 12\text{ V}$	120	140		115	140		110	135		dB
Input Capacitance	C_{IN}			3.2			3.2			3.2		pF
OUTPUT CHARACTERISTICS												
Output Voltage Swing	V_O	$R_L = 10\text{ k}\Omega$	± 12	± 12.6		± 12	± 12.6		± 12	± 12.6		V
POWER SUPPLY												
Power Supply Rejection Ratio	PSRR	$V_S = 3\text{ V to } 18\text{ V}$		0.1	1.8		0.1	3.2		0.2	5.6	$\mu\text{V}/\text{V}$
Supply Current Per Amplifier	I_{SY}	No load		600	725		600	725		600	725	μA
DYNAMIC PERFORMANCE												
Slew Rate	SR		0.1	0.15		0.1	0.15		0.1	0.15		$\text{V}/\mu\text{s}$
Gain Bandwidth Product	GBWP	$A_V = 1$		500			500			500		kHz
Channel Separation	CS	$V_O = 20\text{ V p-p}$ $f_O = 10\text{ Hz}^2$	123	135		123	135		123	135		dB
Capacitive Load Stability		$A_V = 1$ No oscillations		10			10			10		nF
NOISE PERFORMANCE												
Input Noise Voltage Density ³	e_n	$f_O = 10\text{ Hz}^3$		22	36		22	36		22		$\text{nV}/\sqrt{\text{Hz}}$
		$f_O = 1,000\text{ Hz}^3$		11	18		11	18		11		$\text{nV}/\sqrt{\text{Hz}}$
Input Noise Current	$i_{n\text{ p-p}}$	0.1 Hz to 10 Hz		15			15			15		pA p-p
Input Noise Current Density	i_n	$f_O = 10\text{ Hz}$		0.6			0.6			0.6		$\text{pA}/\sqrt{\text{Hz}}$

¹ Guaranteed by CMR test.

² Guaranteed but not 100% tested.

³ Sample tested.

OP400

@ $V_S = \pm 15\text{ V}$, $-55^\circ\text{C} < T_A = +125^\circ\text{C}$ for OP400A, unless otherwise noted.

Table 2.

Parameter	Symbol	Conditions	Min	Typ	Max	Unit
INPUT CHARACTERISTICS						
Input Offset Voltage	V_{OS}			70	270	μV
Average Input Offset Voltage Drift	TCV_{OS}			0.3	12	$\mu\text{V}/^\circ\text{C}$
Input Offset Current	I_{OS}	$V_{CM} = 0\text{ V}$		01	2.5	nA
Input Bias Current	I_B	$V_{CM} = 0\text{ V}$		1.3	5.0	nA
Large Signal Voltage Gain	A_{VO}	$V_O = \pm 10\text{ V}$, $R_L = 10\text{ k}\Omega$ $R_L = 2\text{ k}\Omega$	3000 1000	9000 2300		V/mV
Input Voltage Range ¹	IVR		± 12	± 12.5		V
Common-Mode Rejection	CMR	$V_{CM} = \pm 12\text{ V}$		115	130	dB
OUTPUT CHARACTERISTICS						
Output Voltage Swing	V_O	$R_L = 10\text{ k}\Omega$	± 12	± 12.4		
POWER SUPPLY						
Power Supply Rejection Ratio	PSRR	$V_O = 3\text{ V to } 18\text{ V}$		0.2	3.2	$\mu\text{V}/\text{V}$
Supply Current Per Amplifier	I_{SY}	No load		600	775	μA
DYNAMIC PERFORMANCE						
Capacitive Load Stability		$A_V = 1$ No oscillations		8		nF

¹ Guaranteed by CMR test.

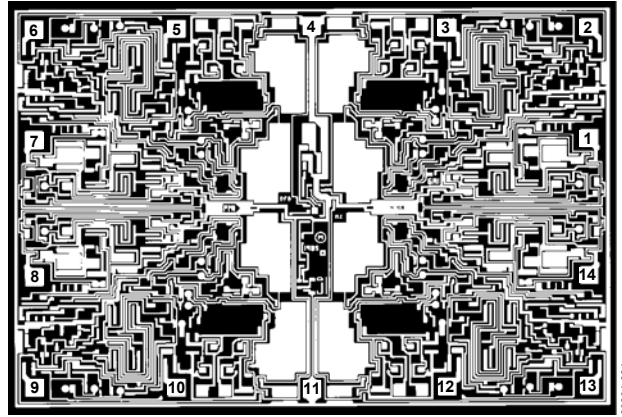

DIE SIZE 0.181 × 0.123 INCH, 22,263 SQ. MILTS
(4.60 × 3.12 mm, 14.35 SQ. mm)

- 1. OUT A
- 2. -IN A
- 3. +IN A
- 4. V+
- 5. +IN B
- 6. -IN B
- 7. OUT B
- 1. OUT C
- 2. -IN C
- 3. +IN C
- 4. V-
- 5. +IN D
- 6. -IN D
- 7. OUT D

Figure 4. Dice Characteristics

@ $V_s = \pm 15\text{ V}$, $-25^\circ\text{C} \leq T_A \leq +85^\circ\text{C}$ for OP400E/E, $0^\circ\text{C} \leq T_A \leq 70^\circ\text{C}$ for OP400G, $-40^\circ\text{C} \leq T_A \leq +85^\circ\text{C}$ for OP400H, unless otherwise noted.

Table 3.

Parameter	Symbol	Conditions	OP400A/E			OP400F			OP400G/H			Unit
			Min	Typ	Max	Min	Typ	Max	Min	Typ	Max	
INPUT CHARACTERISTICS												
Input Offset Voltage	V_{os}			60	220		80	350		110	400	μV
Average Input Offset Voltage Drift	TCV_{os}			0.3	1.2		0.3	2.0		0.6	2.5	$\mu\text{V}/^\circ\text{C}$
Input Offset Current	I_{os}	$V_{CM} = 0\text{ V}$ E, F, G grades H grade		0.1	2.5		0.1	3.5		0.2	6.0	nA
Input Bias Current	I_B	$V_{CM} = 0\text{ V}$ E, F, G grades H grade		0.1	2.5		0.1	3.5		1.0	12.0	nA
Large-Signal Voltage Gain	A_{vo}	$V_{CM} = 0\text{ V}$ $R_L = 10\text{ k}\Omega$ $R_L = 2\text{ k}\Omega$		3000	10,000		2000	5000		2000	5000	V/mV
				1500	2700		1000	2000		1000	2000	V/mV
Input Voltage Range ¹	IVR		± 12	± 12.5		± 12	± 12.5		± 12	± 12.5		V
Common-Mode Rejection	CMR	$V_{CM} = \pm 12\text{ V}$	115	135		110	135		105	130		dB
OUTPUT CHARACTERISTICS												
Output Voltage Swing	V_o	$R_L = 10\text{ k}\Omega$ $R_L = 2\text{ k}\Omega$		± 12	± 12.4		± 12	± 12.4		± 12	± 12.6	V
				± 11	± 12		± 11	± 12		± 11	± 12.2	V
POWER SUPPLY												
Power Supply Rejection Ratio	PSRR	$V_s = \pm 3\text{ V}$ to $\pm 18\text{ V}$		0.15	3.2		0.15	5.6		0.3	10.0	$\mu\text{V}/\text{V}$
Supply Current Per Amplifier	I_{sv}	No load		600	775		600	775		600	775	μA
DYNAMIC PERFORMANCE												
Capacitive Load Stability		No oscillations		10			10			10		nF

¹ Guaranteed by CMR test.

OP400

ABSOLUTE MAXIMUM RATINGS

Table 4.

Parameter	Rating
Supply Voltage	±20 V
Differential Input Voltage	±30 V
Input Voltage	Supply voltage
Output Short-Circuit Duration	Continuous
Storage Temperature Range P, Y Packages	−65°C to +150°C
Lead Temperature (Soldering 60 sec)	300°C
Junction Temperature (T _J)	−65°C to +150°C
Operating Temperature Range OP400A	−55°C to +125°C
OP400E, OP400F	−25°C to +85°C
OP400G	0°C to 70°C
OP400H	−40°C to +85°C

Stresses above those listed under Absolute Maximum Ratings may cause permanent damage to the device. This is a stress rating only; functional operation of the device at these or any other conditions above those indicated in the operational section of this specification is not implied. Exposure to absolute maximum rating conditions for extended periods may affect device reliability.

Absolute maximum ratings apply to both dice and packaged parts, unless otherwise noted.

THERMAL RESISTANCE

θ_{JA} is specified for worst-case mounting conditions, that is, θ_{JA} is specified for device in socket for CERDIP and PDIP packages; θ_{JA} is specified for device soldered to printed circuit board for SOIC package.

Table 5. Thermal Resistance

Package Type	θ_{JA}	θ_{JC}	Unit
14-pin ceramic DIP (Y)	94	10	°C/W
14-pin plastic DIP (P)	76	33	°C/W
16-pin SOIC (S)	88	23	°C/W

ESD CAUTION

ESD (electrostatic discharge) sensitive device. Electrostatic charges as high as 4000 V readily accumulate on the human body and test equipment and can discharge without detection. Although this product features proprietary ESD protection circuitry, permanent damage may occur on devices subjected to high energy electrostatic discharges. Therefore, proper ESD precautions are recommended to avoid performance degradation or loss of functionality.



TYPICAL PERFORMANCE CHARACTERISTICS

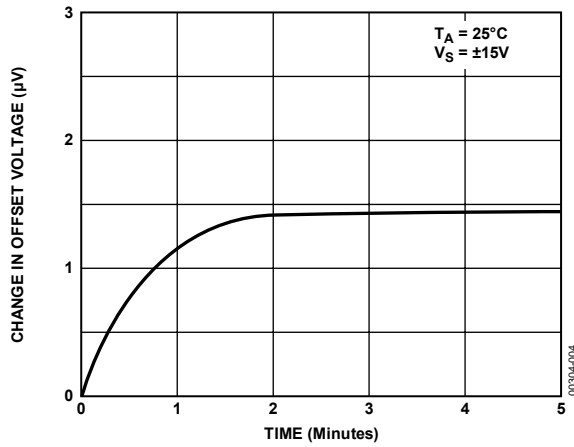

Figure 5. Warm-Up Drift

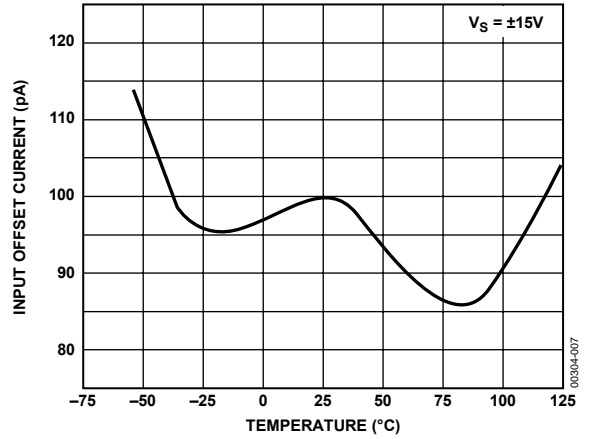

Figure 8. Input Offset Current vs. Temperature

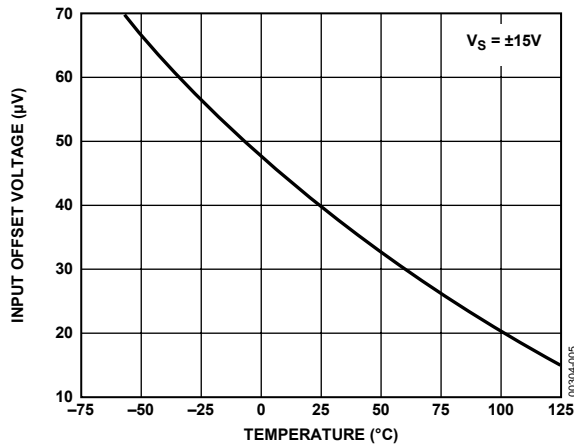

Figure 6. Input Offset Voltage vs. Temperature

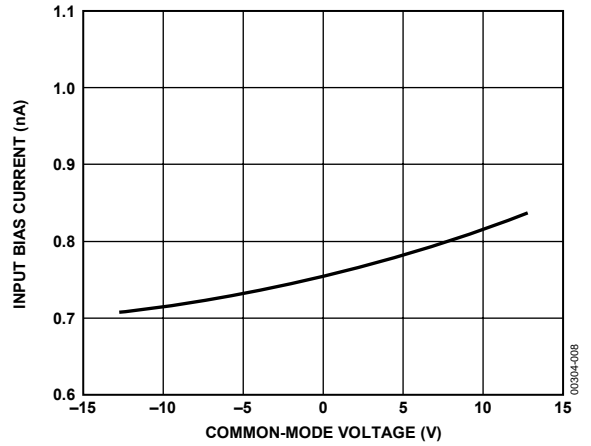

Figure 9. Input Bias Current vs. Common-Mode Voltage

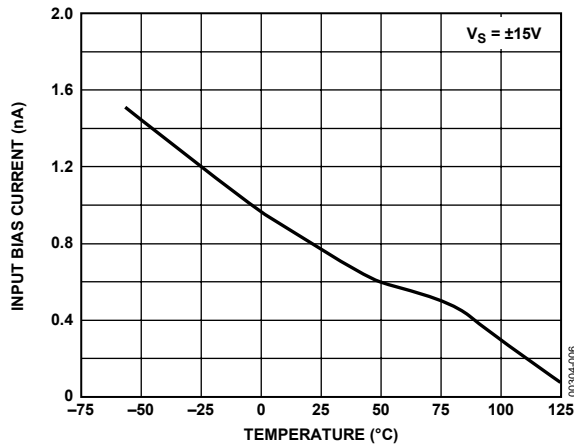

Figure 7. Input Bias Current vs. Temperature

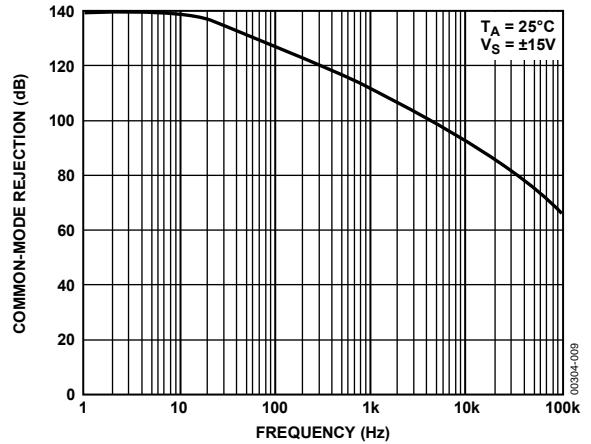

Figure 10. Common-Mode Rejection vs. Frequency

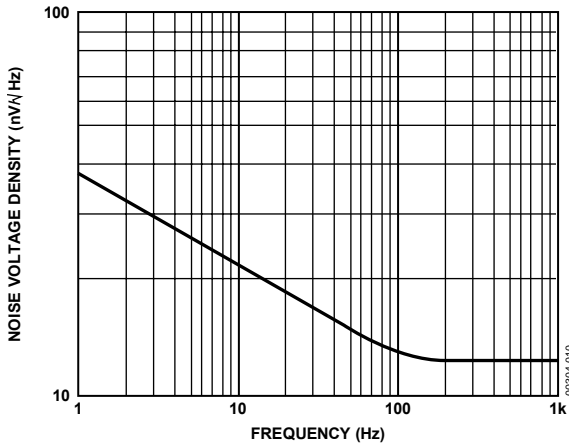

Figure 11. Noise Voltage Density vs. Frequency

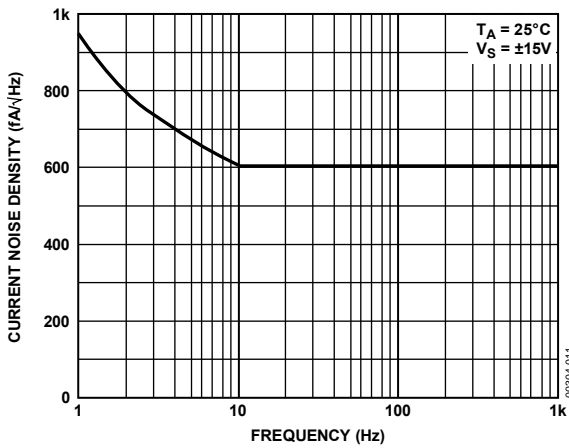

Figure 12. Current Noise Density vs. Frequency

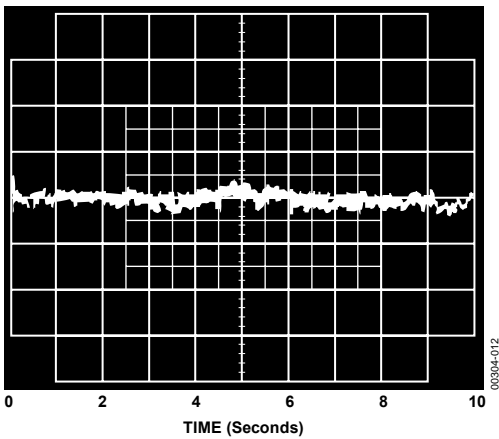

Figure 13. 0.1 Hz to 10 Hz Noise

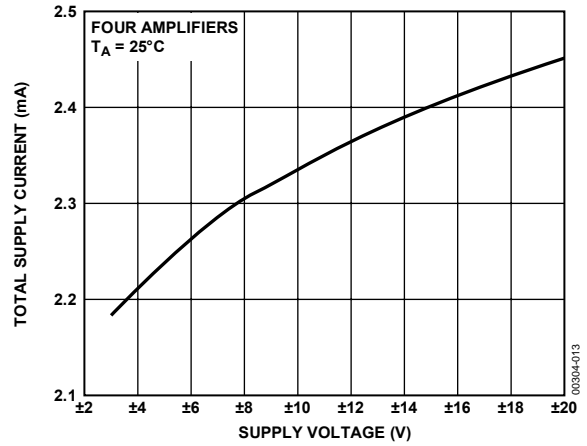

Figure 14. Total Supply Current vs. Supply Voltage

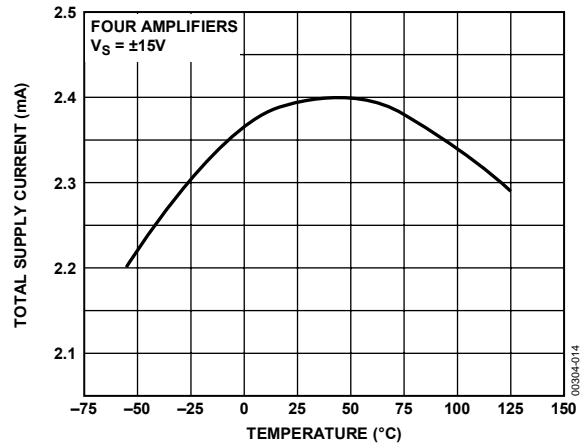

Figure 15. Total Supply Current vs. Temperature

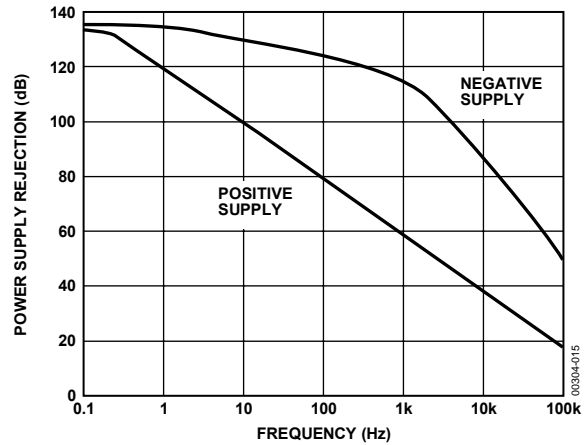

Figure 16. Power Supply Rejection vs. Frequency

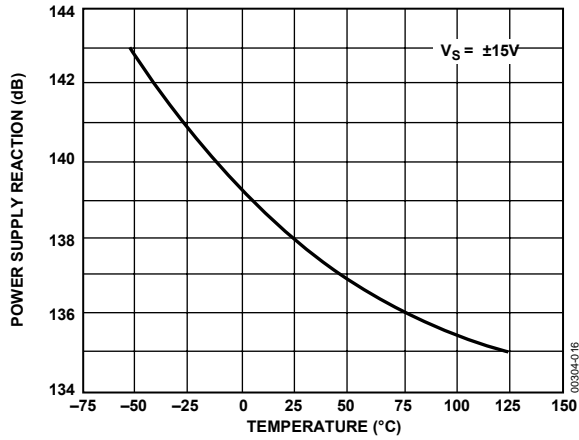

Figure 17. Power Supply Rejection vs. Temperature

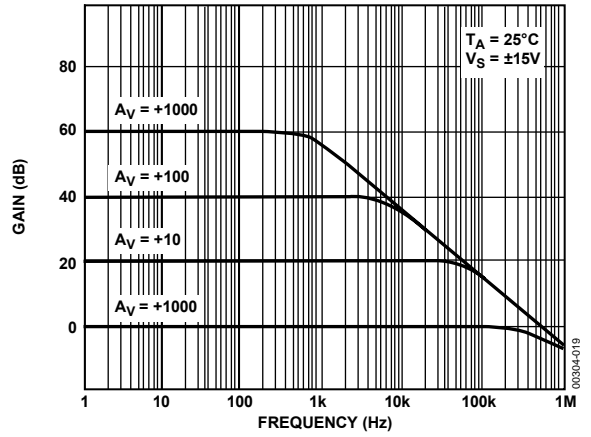

Figure 20. Closed-Loop Gain vs. Frequency

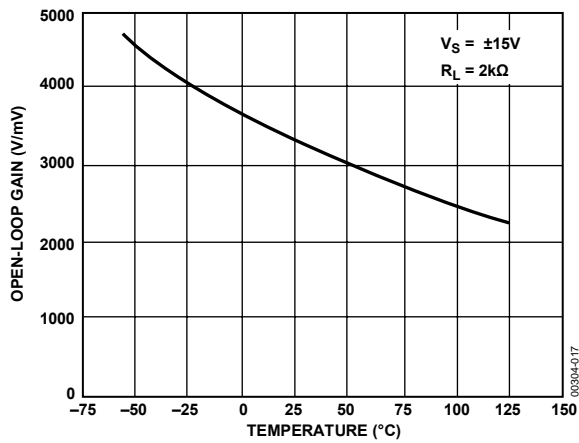

Figure 18. Open-Loop Gain vs. Temperature

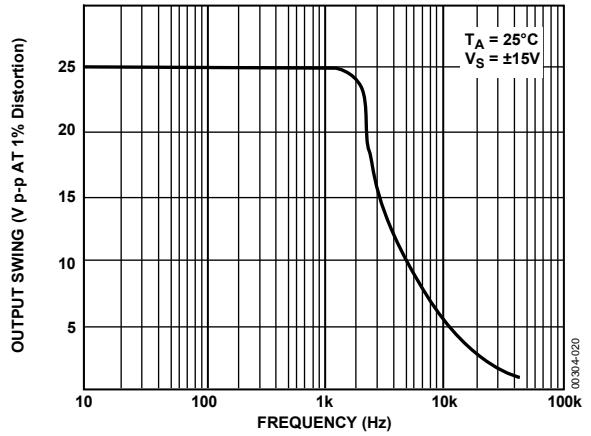

Figure 21. Maximum Output Swing Frequency

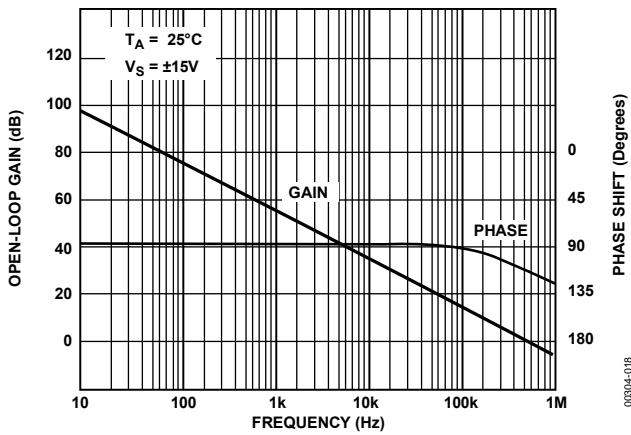

Figure 19. Open-Loop Gain and Phase Shift vs. Frequency

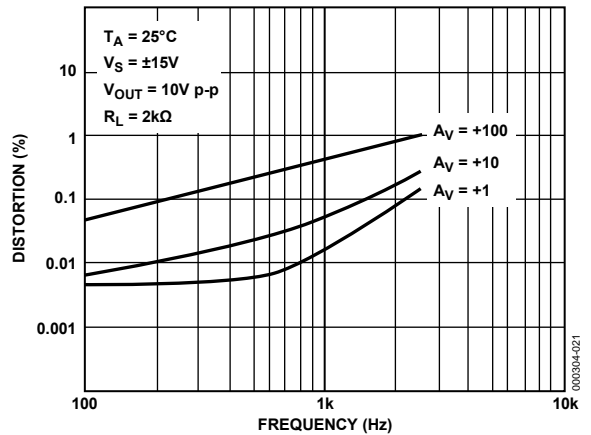

Figure 22. Total Harmonic Distortion vs. Frequency

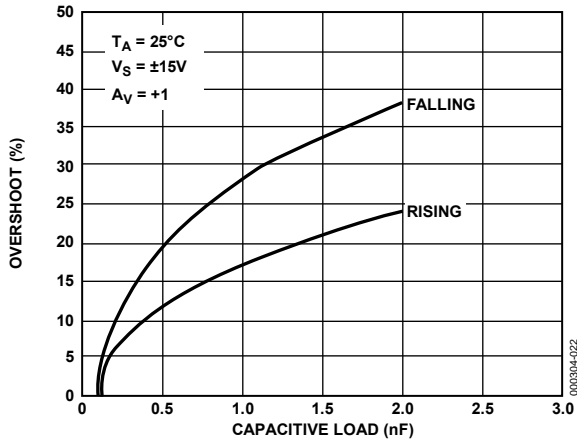

Figure 23. Overshoot vs. Capacitive Load

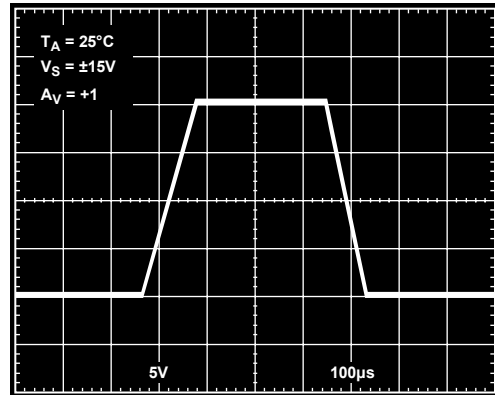

Figure 26. Large Signal Transient Response

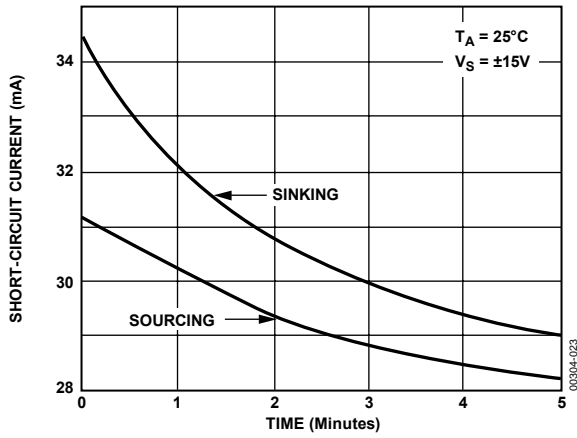

Figure 24. Short Circuit vs. Time

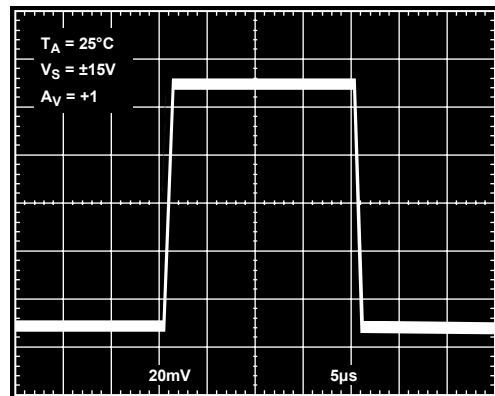

Figure 27. Small Signal Transient Response

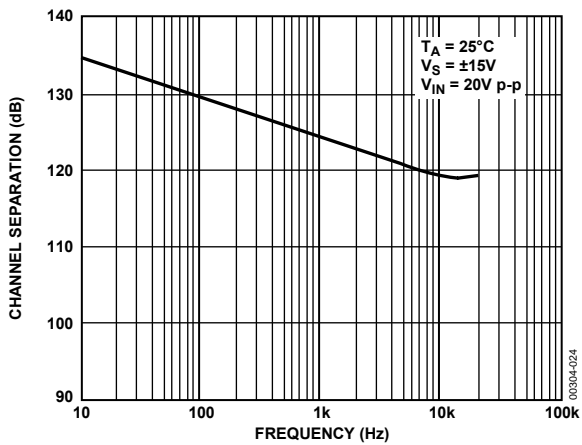

Figure 25. Channel Separation vs. Frequency

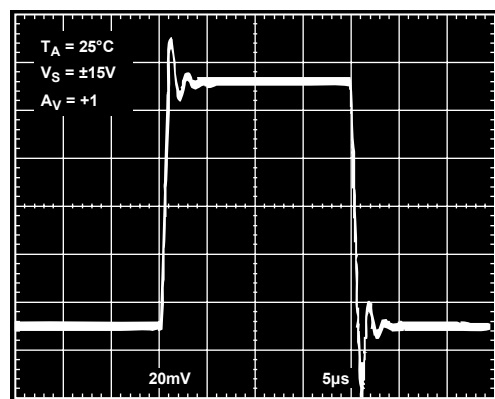

Figure 28. Small Signal Transient Response $C_{LOAD} = 1\text{ nF}$

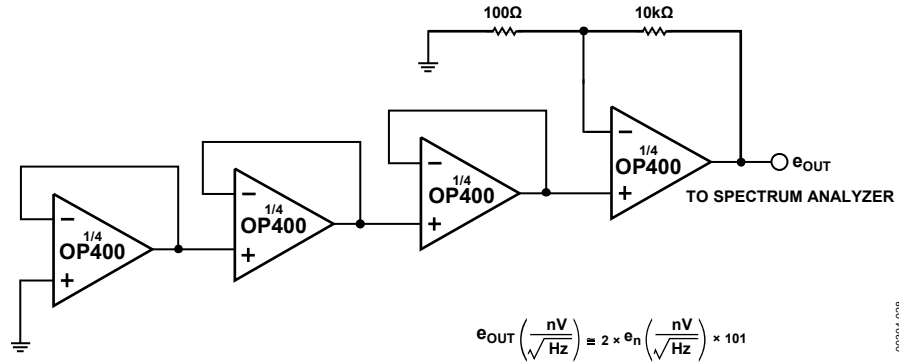

Figure 29. Noise Test Schematic

03304-028

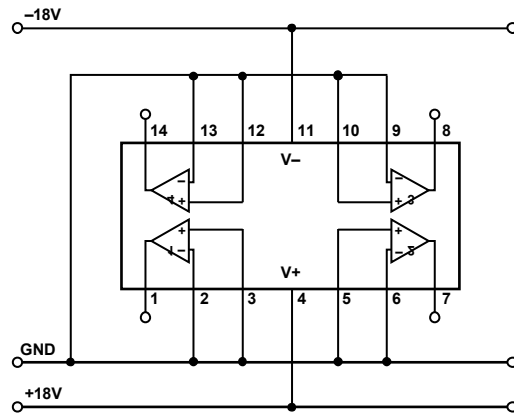

Figure 30. Burn-In Circuit

03304-029

OP400

APPLICATIONS

The OP400 is inherently stable at all gains and is capable of driving large capacitive loads without oscillating. Nonetheless, good supply decoupling is highly recommended. Proper supply decoupling reduces problems caused by supply line noise and improves the capacitive load driving capability of the OP400.

Total supply current can be reduced by connecting the inputs of an unused amplifier to $-V$. This turns the amplifier off, lowering the total supply current.

DUAL LOW POWER INSTRUMENTATION AMPLIFIER

A dual instrumentation amplifier that consumes less than 33 mW of power per channel is shown in Figure 31. The linearity of the instrumentation amplifier exceeds 16 bits in gains of 5 to 200 and is better than 14 bits in gains from 200 to 1000. CMRR is above 115 dB ($G = 1000$). Offset voltage drift is typically $0.4 \mu\text{V}/^\circ\text{C}$ over the military temperature range, which is comparable to the best monolithic instrumentation amplifiers. The bandwidth of the low power instrumentation amplifier is a function of gain and is shown in Table 6.

The output signal is specified with respect to the reference input, which is normally connected to analog ground. The reference input can be used to offset the output from -10 V to $+10 \text{ V}$ if required.

Table 6. Gain Bandwidth

Gain	Bandwidth
5	150 kHz
10	67 kHz
100	7.5 kHz
1000	500 Hz

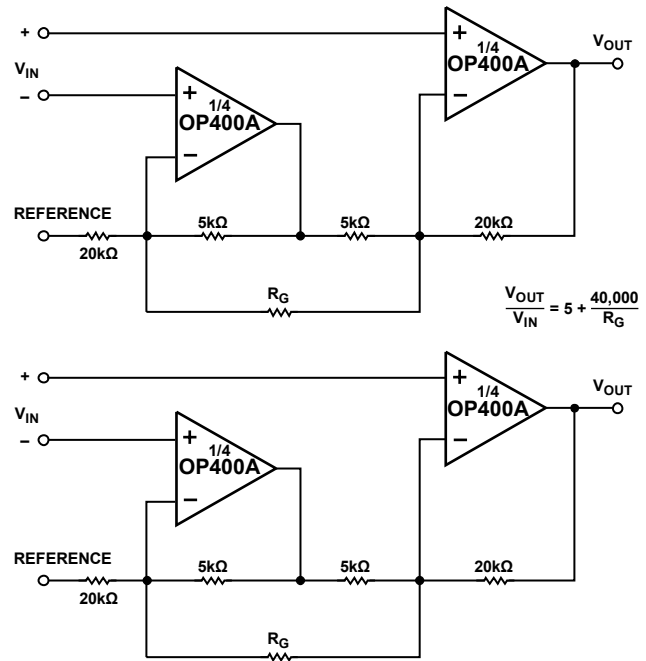

Figure 31. Dual Low Power Instrumentation Amplifier

00304-030

BIPOLAR CURRENT TRANSMITTER

In the circuit of Figure 32, which is an extension of the standard three op amp instrumentation amplifier, the output current is proportional to the differential input voltage. Maximum output current is ± 5 mA with voltage compliance equal to ± 10 V when using ± 15 V supplies. Output impedance of the current transmitter exceeds $3\text{ M}\Omega$ and linearity is better than 16 bits with gain set for a full-scale input of $\pm 100\ \mu\text{V}$.

DIFFERENTIAL OUTPUT INSTRUMENTATION AMPLIFIER

The output voltage swing of a single-ended instrumentation amplifier is limited by the supplies, normally at ± 15 V, to a maximum of 24 V p-p. The differential output instrumentation amplifier of Figure 33 can provide an output voltage swing of 48 V p-p when operated with ± 15 V supplies. The extended output swing is due to the opposite polarity of the outputs. Both outputs swing 24 V p-p but with opposite polarity, for a total output voltage swing of 48 V p-p. The reference input can be used to set a common-mode output voltage over the range ± 10 V. The PSRR of the amplifier is less than $1\ \mu\text{V}/\text{V}$ with CMRR ($G = 1000$) better than 115 dB. Offset voltage drift is typically $0.4\ \mu\text{V}/^\circ\text{C}$ over the military temperature range.

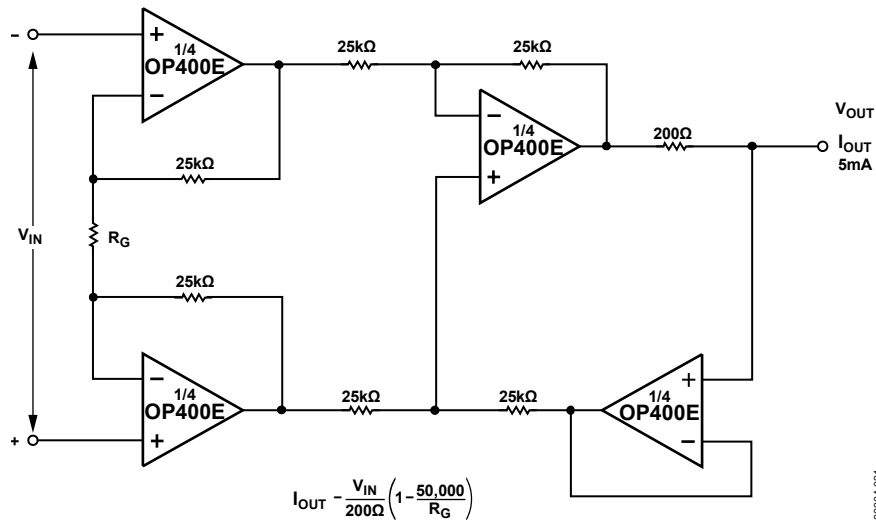

Figure 32. Bipolar Current Transmitter

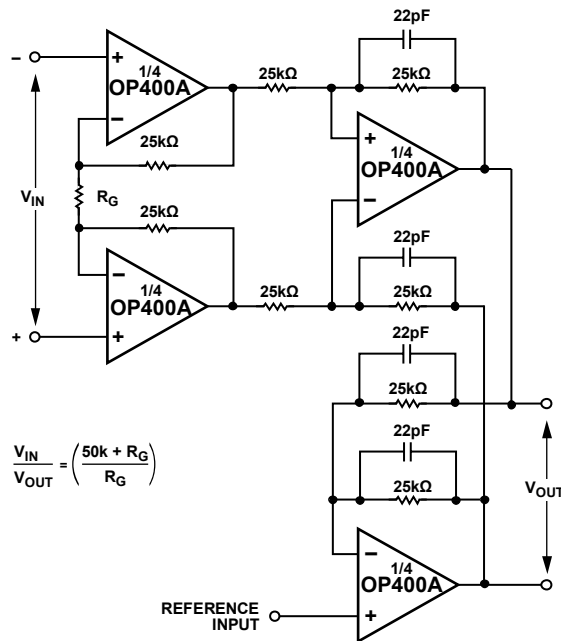

Figure 33. Differential Output Instrumentation Amplifier

MULTIPLE OUTPUT TRACKING VOLTAGE REFERENCE

Figure 34 shows a circuit that provides outputs of 10 V, 7.5 V, 5 V, and 2.5 V for use as a system voltage reference. Maximum output current from each reference is 5 mA with load regulation under $25 \mu\text{V}/\text{mA}$. Line regulation is better than $15 \mu\text{V}/\text{V}$ and output voltage drift is under $20 \mu\text{V}/^\circ\text{C}$. Output voltage noise from 0.1 Hz to 10 Hz is typically $75 \mu\text{V}$ p-p from the 10 V output and proportionately less from the 7.5 V, 5 V, and 2.5 V outputs.

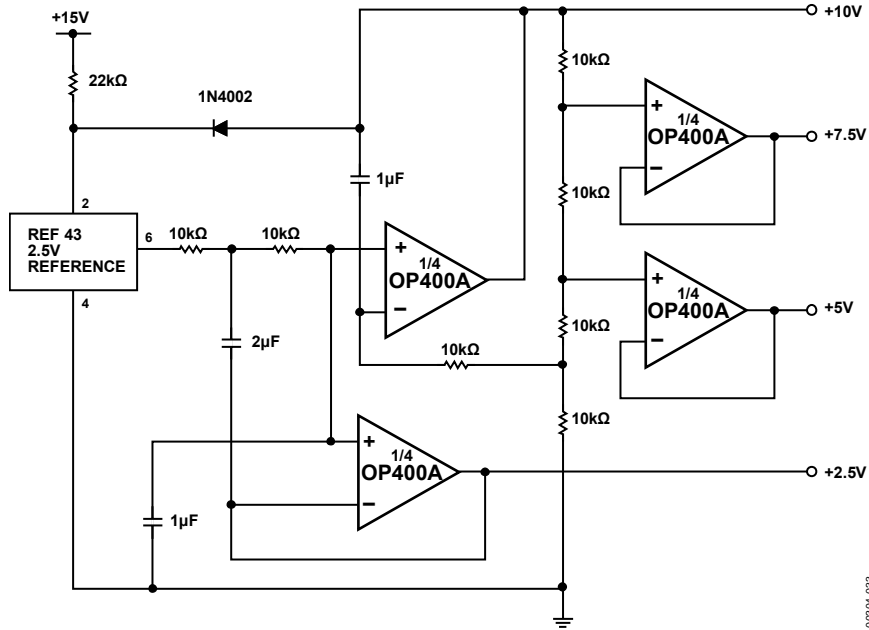
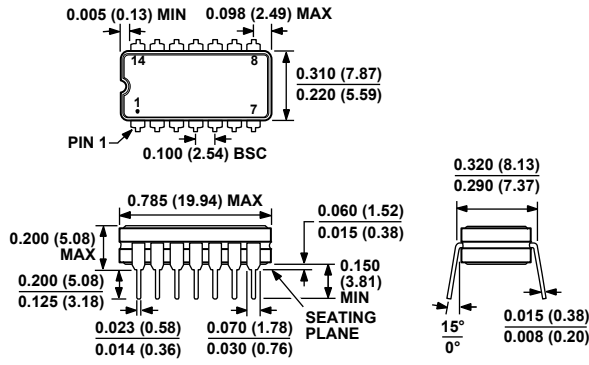

Figure 34. Multiple Output Tracking Voltage Reference

00004-033

OUTLINE DIMENSIONS



CONTROLLING DIMENSIONS ARE IN INCHES; MILLIMETER DIMENSIONS (IN PARENTHESES) ARE ROUNDED-OFF INCH EQUIVALENTS FOR REFERENCE ONLY AND ARE NOT APPROPRIATE FOR USE IN DESIGN.

Figure 35. 14-Lead Ceramic Dual In-Line Package [CERDIP]
(Q-14)
[Y-Suffix]
Dimensions shown in inches and (millimeters)

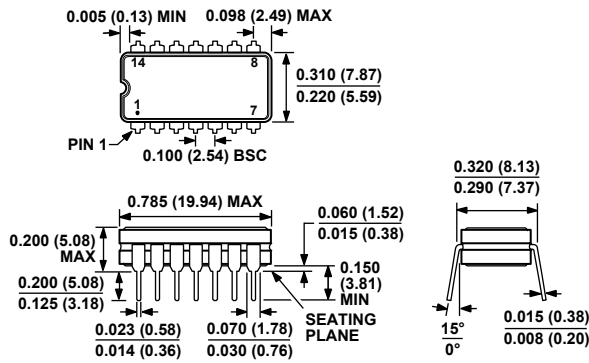

CONTROLLING DIMENSIONS ARE IN INCHES; MILLIMETER DIMENSIONS (IN PARENTHESES) ARE ROUNDED-OFF INCH EQUIVALENTS FOR REFERENCE ONLY AND ARE NOT APPROPRIATE FOR USE IN DESIGN.

Figure 36. 14-Lead Plastic Dual In-Line Package [PDIP]
(N-14)
[P-Suffix]
Dimensions shown in inches and (millimeters)

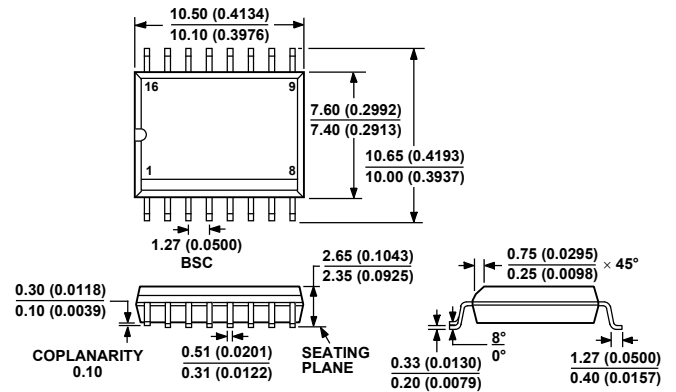

COMPLIANT TO JEDEC STANDARDS MS-013-AA
CONTROLLING DIMENSIONS ARE IN MILLIMETERS; INCH DIMENSIONS (IN PARENTHESES) ARE ROUNDED-OFF MILLIMETER EQUIVALENTS FOR REFERENCE ONLY AND ARE NOT APPROPRIATE FOR USE IN DESIGN.

Figure 37. 16-Lead Standard Small Outline Package [SOIC]
Wide Body (R-16)
[S-Suffix]
Dimensions shown in millimeters and (inches)

OP400

ORDERING GUIDE

Model	Temperature Range	Package Description	Package Option
OP400AY	-55°C to +125°C	14-Lead CERDIP	Y-Suffix (Q-14)
OP400EY	-25°C to +85°C	14-Lead CERDIP	Y-Suffix (Q-14)
OP400FY	-25°C to +85°C	14-Lead CERDIP	Y-Suffix (Q-14)
OP400GP	0°C to +70°C	14-Lead PDIP	P-Suffix (N-14)
OP400GPZ ¹	0°C to +70°C	14-Lead PDIP	P-Suffix (N-14)
OP400HP	-40°C to +85°C	14-Lead PDIP	P-Suffix (N-14)
OP400HPZ ¹	-40°C to +85°C	14-Lead PDIP	P-Suffix (N-14)
OP400GS	0°C to +70°C	16-Lead SOIC	S-Suffix (R-16)
OP400GS-REEL	0°C to +70°C	16-Lead SOIC	S-Suffix (R-16)
OP400GSZ ¹	0°C to +70°C	16-Lead SOIC	S-Suffix (R-16)
OP400GSZ-REEL ¹	0°C to +70°C	16-Lead SOIC	S-Suffix (R-16)
OP400HS	-40°C to +85°C	16-Lead SOIC	S-Suffix (R-16)
OP400HS-REEL	-40°C to +85°C	16-Lead SOIC	S-Suffix (R-16)
OP400HSZ ¹	-40°C to +85°C	16-Lead SOIC	S-Suffix (R-16)
OP400HSZ-REEL ¹	-40°C to +85°C	16-Lead SOIC	S-Suffix (R-16)
OP400GBC		Die	

¹ Z = Pb-free part.

SMD PARTS AND EQUIVALENTS

SMD Part Number ¹	ADI Equivalent
5962-8777101M3A	OP400ATCMDA
5962-8777101MCA	OP400AYMDA

¹ For military processed devices, please refer to the standard microcircuit drawing (SMD) available at www.dsccl.dla.mil/programs/milspec/default.asp.