

QUALITY
INNOVATION
HEALTH
ENJOYMENT

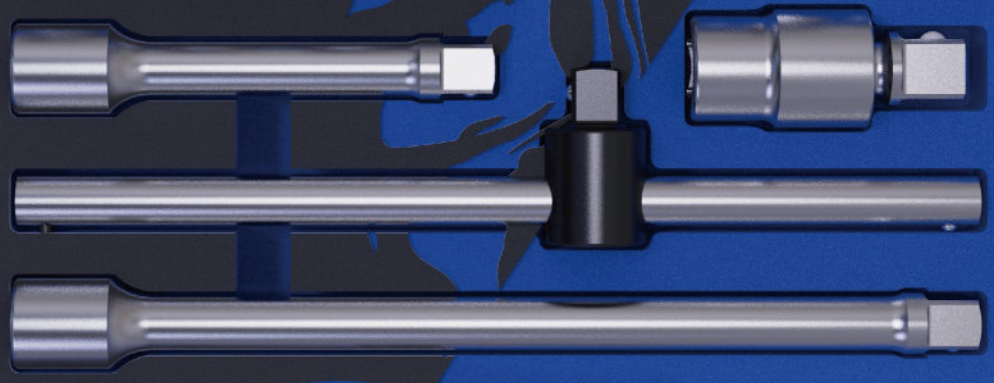

KING TONY

ENJOY YOUR WORK



 KING TONY

2024/25 CATALOGUE



New products

Tools Storage & Tools System Sets

Hand Sockets & Accessories

Impact Sockets & Accessories

Pneumatic Tools

Torque Control & Multipliers

Wrenches

Pliers

Pipe Tools

Screwdrivers & L-wrenches & Bits

VDE Insulated Tools

Electronic & Electrical

Hammers & Striking Tools

Workshop Tools

Lighting

Automotive Tools

ST Series Tools

N1

NEW

16



134



232



264



290



316



350



364



374



424



434



468



476



500



516



614



ST
STARTER

Company Profile

In 1976, amidst a lack of capital and technology in Taiwan, Mr. Charles Lai & Mr. Tony Lin founded a hot forge factory specializing in making hand tools for the DIY market. Eight years later, many other companies had followed their lead and although the market grew quickly, quality suffered. With pricing, costs and quality nearing a state of chaos it became clear to KING TONY's founders that they needed to seek a new direction.

Mr. Lai & Mr. Lin found their new direction; making professional quality hand tools built to compete with the best in the world. They set their standards high and in the years since, have consistently exceeded the requirements of the world's toughest standards. KING TONY tools don't just meet the DIN (German) standard and the ANSI (U.S.A.) standard, they routinely exceed them. In fact, we test every torque make to a standard 30% higher than that prescribed by DIN and our pneumatic impact tools to a 50% higher standard. That's true commitment to quality!

To further underscore our determination to compete with the best in the world we have achieved certification with ISO on three separate standards. First, in January 1998, ISO 9002, followed by ISO 9001 and more recently we have qualified for the environmental safety standard, ISO 14001. We believe that is our responsibility to the world and we will always dedicate to reduce the harm to the earth during our manufacturing process in the future.

You might sense that King Tony Tools is about much more than a world-class tool. The ideals of KING TONY's management are fulfilled daily by our hundreds of employee's at our branches and offices around the world. You will find KING TONY Tools and its branches in: France, Spain, Belgium, Mexico, China. Each of our local branch offices is tasked with insuring that you, our customer, are happy not just with our quality but with the experience of being a KING TONY customer.



1984
Hot
Forge



1989
Tougher
Design



1990
Color Code
Stripe



2023
World
Distribution

2015
Trustworthy
Brand



VISION >>>

KING TONY engaged in supplying professional tools for more than 38 years, we always focus on supplying quality tools to our customers to make sure the quality satisfies the working requirement. To finish a professional job is a dream and target for every mechanic, and to finish it more easily and perfectly is even a better achievement. Thus, every mechanic can really enjoy their work. From this motive we have a goal that is to make every mechanic know, when they use KING TONY professional tools, they will quickly, perfectly and easily finish their work. They may feel more of confidence and enjoy what they do. To achieve this goal, we will continue to supply tools that is easy to take, easy to use, save time and strength. Our future vision is to tell every mechanic who uses KING TONY tools "enjoy your work", which contains the meaning to use good tools to do good jobs and have real enjoyment in the process. Why not find your enjoyment from your job, take KING TONY professional tools and you will start to experience it.



1993
Super
Standard



1996
Close
Tolerance



1999
VDE
Safety
Grip



2012
Dual
Colors
Stripe



2007
Masters
of Torque

BE INSPIRED & MILESTONES



KING TONY

Enjoy your work



Distribution

Branches :

• **France :**

3 Rue des imprimeurs, ZI République Nord,
86000 Poitiers, France

• **Spain :**

Calle Valderribas, 14, Local Comercial Modo,
28007 Madrid, España

• **Belgium :**

Avenue Louise 143, Boîte 4, 1050 Bruxelles

• **Mexico :**

Av San Jose No. 15-A, Col. , Zona Industrial La
Presa, C.P. 54187 Tiainepantia, Edo. De Mexico

• **China :**

No. 3 Building, No. 285 Jingmao Rd.,
Industrial Park of Suzhou, Suzhou, Jiangsu, China



Intellectual Property

New Registered Trademark
Please recognize KING TONY's official registered trademark.



Inspection Equipment



01

Spectrometer

Metal material elements analysis



02

Gauge measurement

Measure the screw tap to meet LEVEL I tolerance of DIN standard



03

Rockwell hardness tester

Test the product's hardness to meet KING TONY quality standard



06

Torque tester

Fracture test to check the max. torque to ensure excess of DIN standard



07

Precise cutting machine

Cut for a smooth section



11

Environmental simulation test of temperature & humidity

Simulate temperature from 70 °C ~ - 20°C to test product reaction and durability while obvious change of temperature



12

Tension tester

Test pulling force of product especially for joint workpiece according to DIN standard



13

Hammering tester

Test the lifetime of striking hammer and security of the joint of hammer & wooden shaft



16

Micro-torque tester

Test products with smaller torque such as bits for their durability



17

Vision measuring machine

Measure parts for difficult angle or in the narrow space



04

Salt-water spray tester

48 HRs environmental simulation test to check product's durability from being rusty



05

Thickness test of plating

Apply special chemical to check thickness of plating and ensure it reaches KING TONY's standard



08

Mounting press machine

In order to fix tiny and multilateral workpiece



09

Grinding & polishing machine

Make surface of workpiece smoother and clearer for further observation

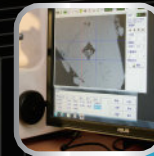

10

Micro-hardness tester

Analyze the change of metallography after heat treatment and the difference of hardness between surface and central location



14

Pliers class measure tester

Test the cutting force and durability



15

Torque wrench tester

Follow the DIN ISO & ASME standard to test torque tolerance by 3 points of the lowest point, 60%, and 100% of max. scale



18

Carton busting strength tester

Test the strength of carton in order to assure good packing quality



19

Insulated tester

Ensure products are insulated under the voltage 1000V

Production Process



01

Hot forge

Heat to take shape and complete fibers to improve durability



02

Lathing

Control sockets external diameter and the roundness



03

Drilling

Drilling pin hole on the groove to offer socket safety operation



06

Punching & Broaching

Make accurate dimension for the spanner



07

Marking

Stamp dimensions, material and manufacturer



11

Grinding

Remove oxide layer and ensure sockets roundness for follow process precision



12

Plating

Nickel-chrome plated to protect product from corrosion and improve finish



13

Phosphate sink

Increase impact sockets wear resistant and prevent corrosion to improve the durability



04

Machining (CNC)

Finish complicated process to ensure the precision of product



05

De-burring

Remove the burrs and chamfer on square hole



08

Heat treatment

Enhance product performance to achieve max. hardness



09

Vibrating

Remove oxide layer and burrs for surface coating



10

Sand blast

Remove oxide layer and burrs for surface coating



14

Silk printing

The unique bi-colors silk printing design and is easy to distinguish metric and imperial dimension



15

Rubber stripe assembly

The unique bi-colors rubber stripe design and is easy to distinguish metric and imperial dimension



Exhibitions



Sponsor & Partnership





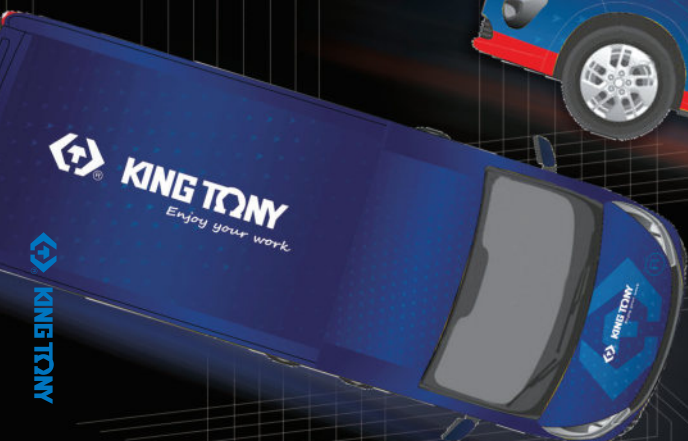

Branding to Target Users



KING TONY TOOL TROLLEYS

SQUAD **Series**

KING TONY is very devoted to developing professional tools that meet user needs. In order to create a better storage for your professional tools, we have developed a new series of work station. From tool trolley to workbench, they are all the necessities for a professional mechanic

From industry, auto repair to general repair channel, we have visited countless users to hear their aspirations for tool storage. The purpose is to design the best meet needs product. It's consistent with our brand vision, "To provide professional tools to make customers feel comfortable and to help them with their work"

Just as our new series of tool trolley, the birth of this professional tool trolley series are to fulfill the needs of tool storage

Each model contain it's own characters for various of circumstances.

The ultimate purpose is to have them become your trustiest backup and support in your garage



Load bearing



- Overall supporting weight for tool trolley at a safety level



- Overall supporting weight for drawers at a safety level



Convenient



- Convenient and safety with Central lock system



- 100% drawer opening, does not interfere with the removal of tools



- 360° swivel wheel with brake function



- The size of the drawer conforms to TCS, and the tool set can be purchased freely according to the demand

Robustness



- Body frame are constructed with one-piece steel sheet for integral strength



- The bottom of the drawers are stamped in order to strengthen effectively

Protection



- Protection bumpers are for to avoid collisions and to protect object during maneuver



- Risk Free System (RFS) allows open one drawer at a time which prevents the loss of center of gravity from tilting and instability



- Press to open drawer is a safe and reliable system

SQUAD Tool Trolley

For time being, KING TONY has reached to another level of making tools trolley, in this year, we have invested a whole new direction for your satisfaction. Newly from concept to final product, from structure to finishing and even from top to bottom, we strive all our best into them

Start from the series name "SQUAD", it comes from the gaming industries, we believe this trolley can be extended to other business, and gaming is one of the potential market. This wording means a professional team which is us at KING TONY

This series have 4 models, Model D, Model D+, Model Dx, Model SW. Each model size are differ, storage space are not the same, it depends on your demand. Certainly one of them would fulfill your garage
This series of tools trolley is a milestone for KING TONY

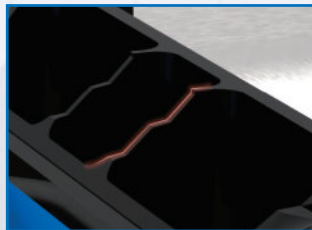

- Shape and outline of bumpers correspond to the lid, which makes a connection in between, with cut through pattern shows more energetic outlook
- ABS corner protection bumper

- keylock usually in front or in the middle or side of the drawers, The reason we place in the corner is we have noticed that the keys will swing around while trolley was moving and scratched the surface of the trolley plus it altered the outlook



Normal way of using handle

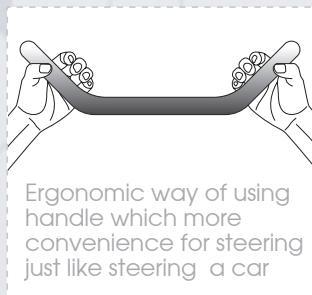

Ergonomic way of using handle which more convenience for steering just like steering a car



- Extra-large ergonomic handle



NEW

KING TONY

Model D

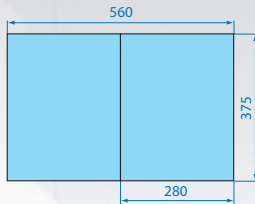

Model D^x

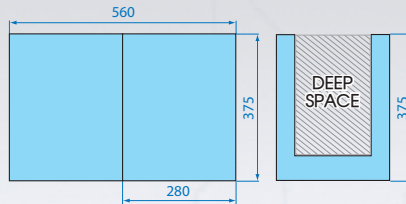

Model D⁺

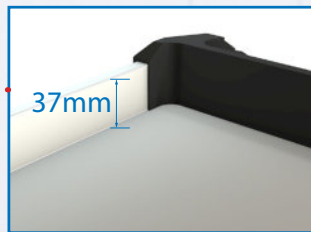
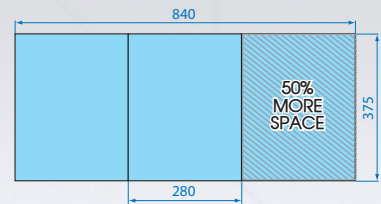

• Worktop depth has increased than previous models, parts are less likely to roll out



• Two models come in different size worktop



• Trapezoidal-shape storage space, easy to reach stuff



• Dual colors
• With brake systems



• Aluminum drawer strip, easy to pull out
The drawer is with auto closure function

Features

- Dynamic top cover
- Stainless steel worktop
- Structure strengthen
- Stylish bumpers
- Additional space for accessories
- Aluminum drawer handle
- RFS locking system (one drawer at a time)
- 5"x2" TPR high performance casters
- Central key lock
- 100% pull out drawer with auto-return



Model D

87SQ31

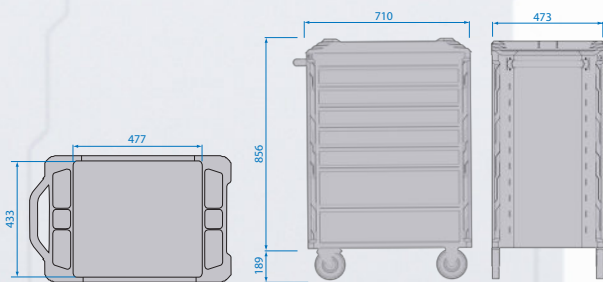
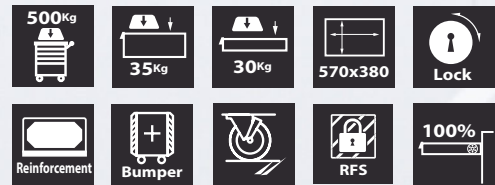

KT NO.	Spec.	Dimension(mm) Width x Depth x Height	Casters	Static load		CUFT
87SQ31-6B-BK	3 Drawers	570 x 380 x 70	5"x2"	500	63.00	14.30
	3 Drawers	570 x 380 x 150				
87SQ31-7B-BK	5 Drawers	570 x 380 x 70				
	2 Drawers	570 x 380 x 150				
87SQ31-8B-BK	7 Drawers	570 x 380 x 70				
	1 Drawers	570 x 380 x 150				

NEW

KING TONY

Model D^X

87SQ32

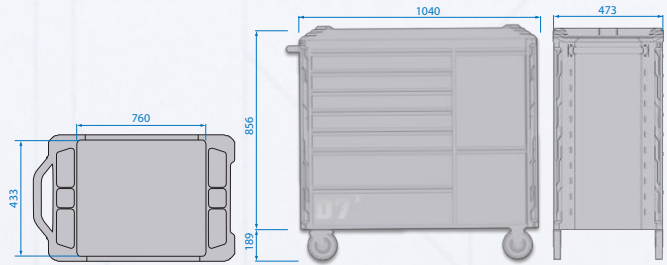

KT NO.	Spec.	Dimension(mm) Width x Depth x Height	Casters	Static load	kg	CUFT
87SQ32-8B-BK	3 Drawers	570 x 380 x 70	5"x2"	700	90.00	22.85
	3 Drawers	570 x 380 x 150				
	Square Drawer	270 x 380 x 280				
	Bulk Square Drawer	270 x 380 x 380				
87SQ32-9B-BK	5 Drawers	570 x 380 x 70				
	2 Drawers	570 x 380 x 150				
	Square Drawer	270 x 380 x 280				
	Bulk Square Drawer	270 x 380 x 380				
87SQ32-10B-BK	7 Drawers	570 x 380 x 70				
	1 Drawers	570 x 380 x 150				
	Square Drawer	270 x 380 x 280				
	Bulk Square Drawer	270 x 380 x 380				

Model D⁺

87SQ33

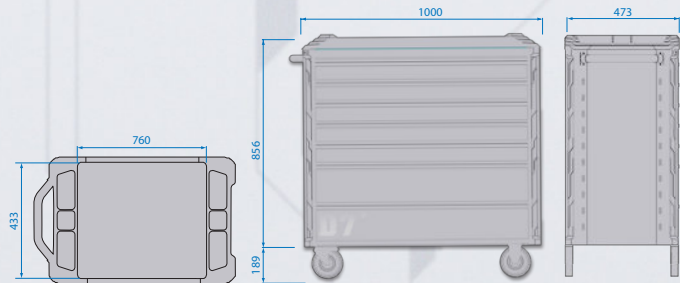

KT NO.	Spec.	Dimension(mm) Width x Depth x Height	Casters	Static load	kg	CUFT
87SQ33-6B-BK	3 Drawers	850 x 380 x 70	5"x2"	700	81.00	22.03
	3 Drawers	850 x 380 x 150				
87SQ33-7B-BK	5 Drawers	850 x 380 x 70				
	2 Drawers	850 x 380 x 150				
87SQ33-8B-BK	7 Drawers	850 x 380 x 70				
	1 Drawers	850 x 380 x 150				

NEW

KING TONY

Superb Workbench

Within this series, we are delighted to introduce new Superb workbench
An advanced model that absolutely would be no miss in your garage

Every inch of space can be used in this trolley,

It has enormous amount of storage space
equipped with 10 standard drawers, 1 peg board drawer, 3 cabinets with lock
Besides, unlike what you have seen in market, each side of this trolley are
functionable

Would be ideal for a team of professionals to share this tank and of course solitary is
also suitable

Furthermore, extra large and thickness working wooden top allows you to study your
products in details and longer durations without damaging body of the trolley

1 meter in height suits most people at a comfortable position

This highly functionable super tank are made for professional



- Doors cabinet with key lock for valuable electronic products
- Internal size : 654x376x205mm



- Able to fit other common accessories
Size 435x501mm



- Additional storage space



- Vertical wrenches peg board drawer for hanging
wrenches vertically
- Internal size : 385mm x 378mm



- Paper roll trash bin or could be
can/bottle holder
- Paper roll holder
Size 435x501mm

NEW

KING TONY

87SQ34-10B-BK

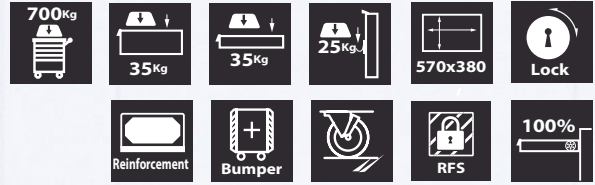

- Wide work top given 1235mm x 800mm space
- High end extra thick wood top
- Extra long metal handle bar for easy maneuver
- 10 drawers, plus 1 wrench hanging drawer
- 3 storage cabinets, from large to small for different storage purposes, all with key locks
- Able to fit other common accessories
- Absolute rectangular shape which fits every corner

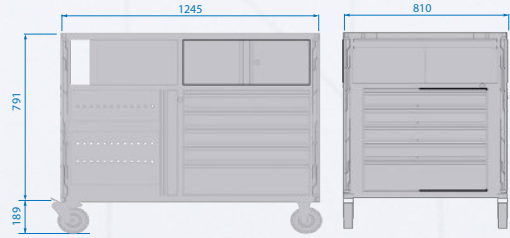

KT NO.	Spec.	Dimension(mm) Width x Depth x Height	Casters	Static load	Kg	CUFT
87SQ34-10B-BK	8 Drawers	570 x 380 x 70	5"x2"	700	130.00	41.63
	2 Drawers	570 x 380 x 150				



- Thickness: 32mm
- Size: 1235x800mm

- Extra long Handle bar

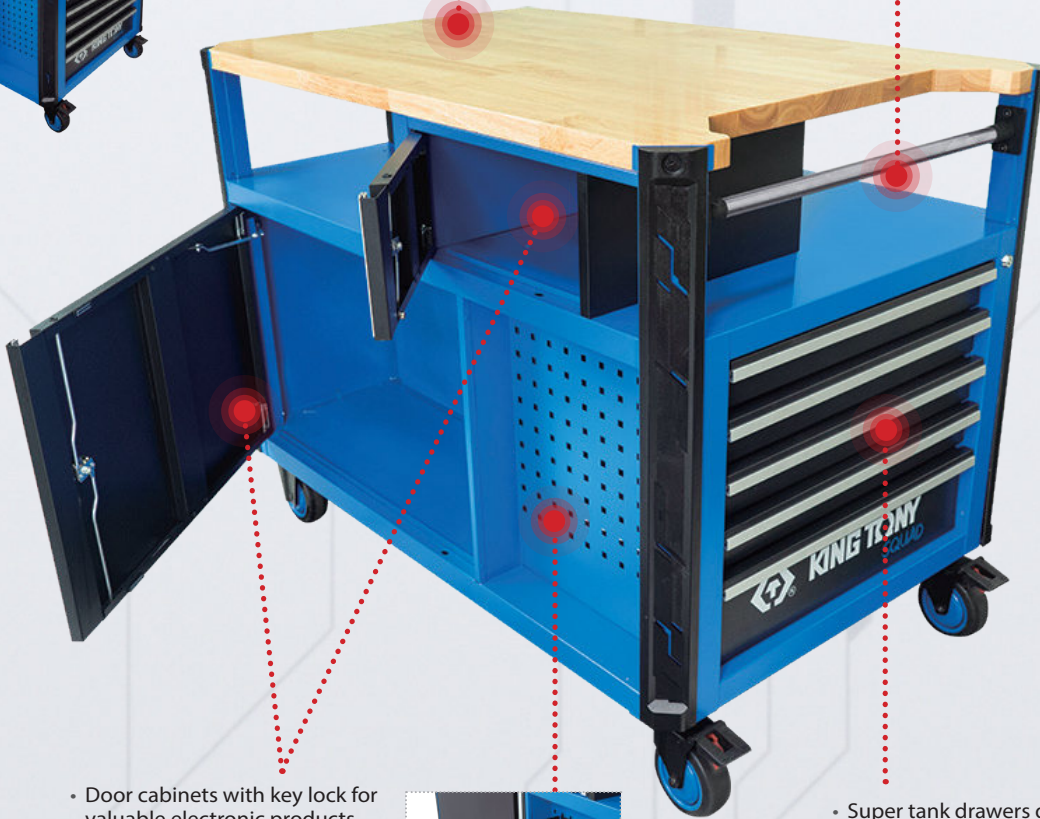

- Door cabinets with key lock for valuable electronic products
- Internal size: 389x406x202mm
- Internal size: 791x523x329mm



- Size: 426x499mm

- Super tank drawers dimension
- Internal size : 570x380x70mm
- Internal size : 570x380x150mm
- Multiple drawers at side

NEW

KING TONY

Accessories



Hook type

87SQ3-11



- Side pegboard
- If the right side of trolley do not have enough sufficient space, you might as well bought additional peg board for accessories (W)325 x(H)683

87SQ3-12



- Document holder (W)325 x(H)260 x(D)34

87SQ3-22



- Bottle holder (W)320 x(H)101 x(D)74

87SQ3-13

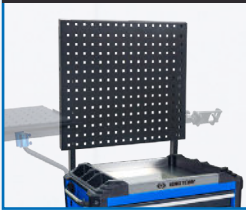

- Shelf pegboard (W)640 x(H)540

87SQ3-32



- Phone holder (W)200 x(H)52

87SQ3-31

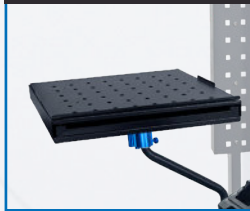

- Laptop or ipad holder (W)378 x(D)285 x(H)79



- 3 angles of adjustment are available, 20°/45°/60°
- Can be turned left or right 360°



- Underneath the rack has a drawer for stationery storage



NEW

KING TONY



Hook type

87SQ3-23



- Power tools holder (W)285 x(D)172 x(H)71

87SQ3-33

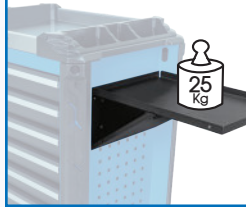

- Folding shelf (W)398 x(D)280 x(H)179

87SQ3-41



- Trash bin (W)275 x(D)150 x(H)136

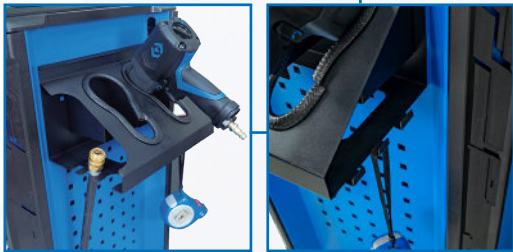

- Left side of holder has three slots that are able to hang tools, hose or wrenches etc
- Right side of holder has 3 hooks for cleaning cloths, gloves, wires etc

87SQ3-42



- Trash bin-25 Liters (W)363 x(D)232 x(H)411
- handle slots on the side

87SQ3-51



- Paper holder (W)280 x(D)308
- For paper roll within 280mm wide



- Another strength of the accessories is that the paper roll can be inserted on top of the trash bin, which can be used both at the same time at the same place, it can also be used separately. This combination makes more user friendly and unique for this trolley

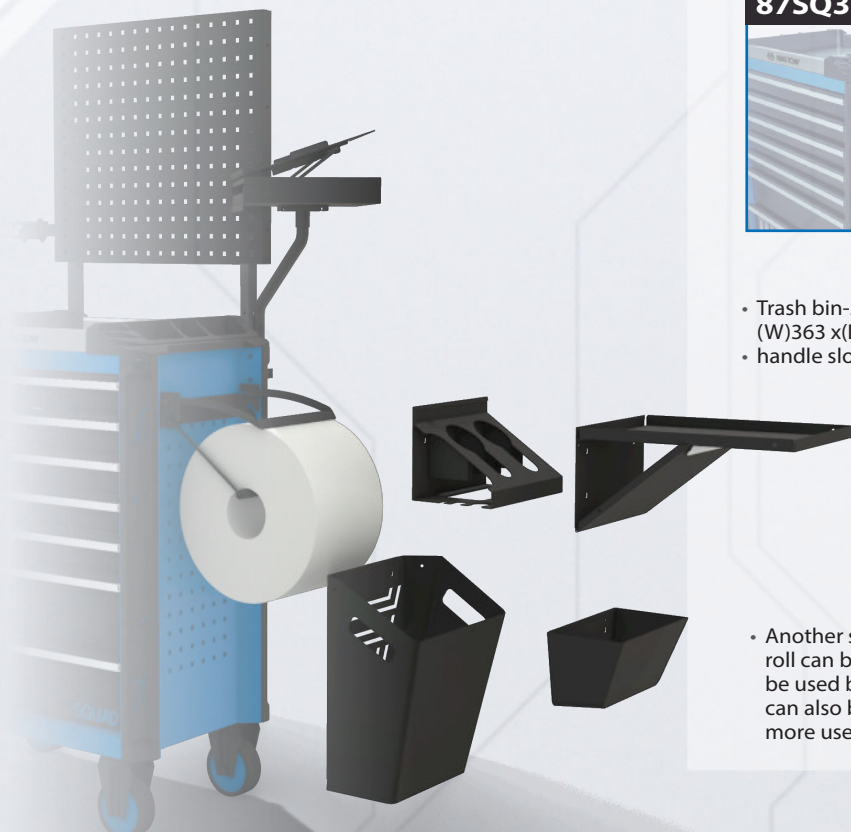

Tool Set Content

9-91215MRV

Blow case size (mm) :
422 x 360 x 90 (0.48 cuft)

Contents		5.11	1 / 4
1062	27, 28, 29, 30, 32		
373A	8, 10, 11, 13, 17, 19, 22, 24		
3611-12R	6011-10R		



15 PC.

Tray category #6 (560 x 375mm)

Tool Set Content

934-086MRVD

86 PC.

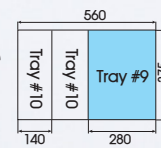
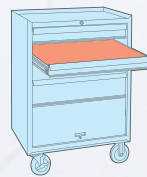

Drawer (579 x 380 mm)



9-12FVE15MRV #9 P.84



9-12FVG15MRV #9 P.84

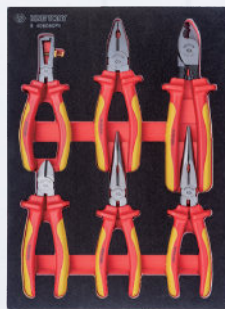

9-40606GPV #9 P.85



9-55VE01MRV #9 P.84



9-30612MRV #9 P.85



NEW

KING TONY

Insulated Tool Set

Handy case size (mm) :
372 x 422 x 92 (0.51 cuft)

30VE31MPV

3/8"

Contents		Kg 4.21	1 / 3
⊖	3335VE	6, 7, 8, 9, 10, 11, 12, 13, 14, 15, 16, 17, 18, 19	
	10FOVE	7, 8, 10, 12, 14	
	3221VE	6, 10	
	3771VE-08		
⊖	1471	VDE PH1 x 100, PH2 x 100	
	1472	VDE 3 x 75, 4 x 100, 5.5 x 125	
	6116-07A	6216-06A	
	6318-08A	6CB02	



31
PC.

NEW

9-35VE02MRV

3/8"

Contents		Kg 1.52	1 / 10
⊖	3335VE	06, 07, 08, 09, 10, 11, 12, 13, 14, 15, 16, 17, 18, 19	
	10FOVE	7, 8, 10, 12, 14	
	3221VE	6, 10,	
	3771VE-08		



22
PC.

Tray category #9 (375 x 280mm)

9-90VE09CRV

Contents		Kg 1.20	1 / 10
⊖	1471	VDE PH1 x 100, PH2 x 100	
⊕	1472	VDE 3 x 75, 4 x 100, 5.5 x 125	
	6116-07A	6216-06A	
	6318-08A	6CB02	



9
PC.

Tray category #9 (375 x 280mm)

KING TONY

Wheel Nut Impact Socket & Set

44904MP01

1/2"

- Thin wall impact socket set with plastic sleeve
- Color coded, sizes are easy to recognize
- Material: Chrome molybdenum alloy steel
- The design of protective sleeve is able to reduce the wear of sheath and avoid damaging the aluminum alloy rims

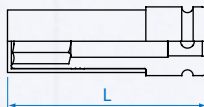

1.12 kg / 1 / 20



4 PC.

Blow case size (mm) :
160 x 135 x 50 (0.038 cuft)

Contents	DR.	Applicable vehicle	Size mm	L mm
494515M	1/2"	Smart	15	85.0
494517M	1/2"	-	17	85.0
494519M	1/2"	-	19	85.5
494521M	1/2"	-	21	85.5

44904MP02

1/2"

1.12 kg / 1 / 20

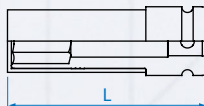

4 PC.

Blow case size (mm) :
160 x 135 x 50 (0.038 cuft)

Contents	DR.	Applicable vehicle	Size mm	L mm
494517M	1/2"	-	17	85.0
494519M	1/2"	-	19	85.5
494521M	1/2"	-	21	85.5
494522M	1/2"	Opel	22	85.0

Wheel Nut Impact Socket Set

44907MP

1/2"

1/2"

2.13 kg / 1 / 12

Contents	DR.	Applicable vehicle	Size mm	L mm
494515M	1/2"	Smart	15	85
494517M	1/2"	-	17	85
494519M	1/2"	-	19	85
494521M	1/2"	-	21	85
494522M	1/2"	Opel	22	85
9BW4501	1/2"	Mercedes Benz	17	85
9BW4502	1/2"	Hyundai/Kia	21	85



7 PC.

NEW

KING TONY

Impact Socket Set

4421MP1 1/2"

Contents	1.69	1 / 12
4535M	10, 11, 13, 17, 19, 22, 24, 27, 29, 30, 32	



11
PC.

Impact Socket Set

6424MP 3/4"

Blow case size (mm) :
422 x 360 x 90 (0.48 cuft)

Contents	11.58	1 / 2
6535M	24, 27, 30, 32, 33, 34, 36, 38, 41, 46, 50, 55, 60, 65,	

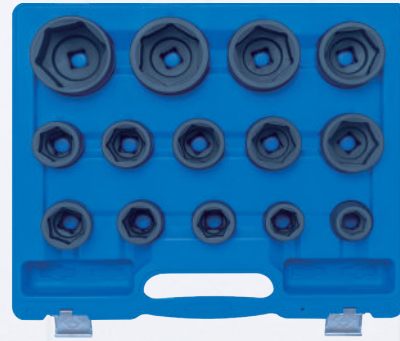

14
PC.

Brake Caliper Socket Set

9BC4A05MP

- Brake caliper socket set dedicated to Volkswagen, Audi and Porsche (VAG) vehicles.
- 10-tooth sockets: 11.5 mm - 15 mm - 20 mm
- 7-tooth socket: Ø 14 mm - 22 mm

1.18 2 / 24

KT NO.	Specification (mm)	Applicable car models
9BC42A11	10-tooth : 11.5	Porsche
9BC42A15	10-tooth : 15	Audi Q7, S8 & Porsche Macan, Cayenne, Cayman
9BC42A20	10-tooth : 20	Audi A8, S6 & Porsche Cayenne
9BC41A14	7-tooth : 14	Audi Q7 and S4
9BC41A22	7-tooth : 22	Audi S5

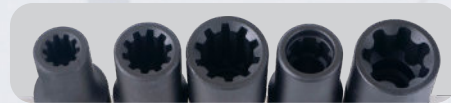

5
PC.

Impact Bit Socket

8015M

KT NO.	mm	L mm		
801524M	H24	80	741	1 / 24
801527M	H27	80	776	1 / 24
801530M	H30	80	820	1 / 24
801532M	H32	80	851	1 / 24
801536M	H36	80	921	1 / 24

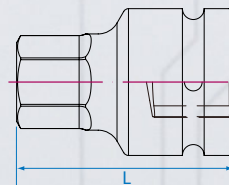

Brake Caliper Slogging Wrench

10B0B



- Use for the assembly and removal of the brake caliper screw connections on commercial vehicles
- Designed with a 3/4" DR., can be used with torque wrenches for tightening operations
- The torque adjustment formula laser etched onto the wrench for calculating the correct setting torque when tightening the fixings

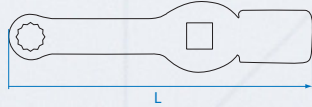
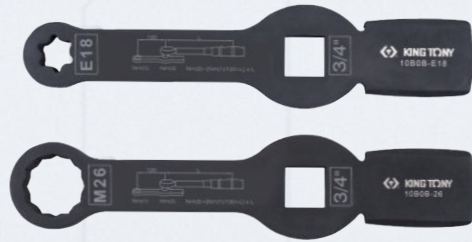

KT NO.	Size mm	Application	L mm		
10B0B-24	M24	SAF	215	580	1 / 24
10B0B-26	M26	DAF XF, XF95, XF105, XF106	220	580	1 / 24
10B0B-E18	E18	MAN TGL, TGM	215	580	1 / 24
10B0B-E20	E20	MAN TGL, TGM	215	580	1 / 24
10B0B-E24	E24	MAN TGA, TGS, TGX	220	580	1 / 24

Portable Wrench Set

KT NO.	PC.	Contents	Package		
12D06MRS01	6	1062 10, 11, 13, 14, 17, 19	color box	0.82	1 / 20
122A06MR	6	373AM 10, 12, 13, 14, 17, 19	color box	-	1 / 10
122A06MR01	6	373AM 8, 10, 12, 13, 14, 17	color box	1.12	1 / 10



NEW

KING TONY

4 in 1 Ratcheting Wrench & Set

3739J

- 4 sizes combine in 1 wrench, total 8 sizes as a set, common size for general applications
- Compact ratchet mechanism with reversible function
- 120-teeth precision ratchet gears only need minimal 3° to move fasteners
- Anti-slip teeth, suitable for 80% rounded bolt
- High quality durable chrome vanadium exceeds DIN standard
- Hexagon ring design provides a better torque capacity



▪ Combine four general sizes in one wrench



▪ Suitable for use confined space



▪ Reversible ratchet with 120 teeth gear design

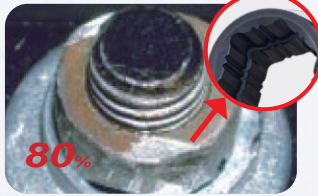

▪ Anti-slip teeth, suitable for 80% rounded bolt

KT NO.	Size mm	D1 mm	D2 mm	H1 mm	H2 mm	L mm	⚖️	📦
3739J0813M	8 x 10 x 12 x 13	22	26.6	13.5	16.4	169	117	12 / 192
3739J1619M	16 x 17 x 18 x 19	31	35	19.8	21.2	199	225	6 / 72

14902JMR01



2 PC.

KT NO.	PC.	Contents	⚖️	📦
14902JMR01	2	8 x 10 x 12 x 13, 16 x 17 x 18 x 19	0.34	1 / 24

132A13MR01

Blow case size (mm) :
303 x 228 x 50 (1.35 Cuft)

Contents ⚖️ 1.64 📦 1 / 8



13 PC.

Thread Repair File

75RF09M

- For the restoration of defective internal and external threads
- Suitable for right and left-handed thread
- Suitable for metric pitch: 0,80 - 1,00 - 1,25 - 1,50 - 1,75 - 2,00 - 2,50 - 3,00

⚖️ 164 📦 12 / 120

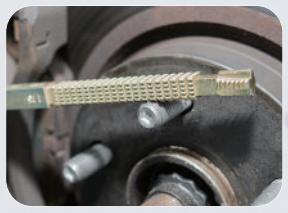

NEW

KING TONY

6PC. Adapter Set

78106

- According to DIN 3123 / ISO 3316
- Square drive adaptor to DIN 3120 / ISO 1174 with ball lock
- Internal square to DIN 3120 / ISO 1174 with ball reception
- For manual operation









1.31 kg / 1 / 20

DIN 3123

ISO 3316

Cr-V

Chrome plated

M	Contents	F	M	Contents	F
3/8 DR.		1/4 DR.	3/8 DR.		1/2 DR. 
	2813			4813	
1/4 DR.		3/8 DR. 	3/4 DR.		1/2 DR.
	3812			4816	
1/2 DR.		3/8 DR.	1/2 DR.		3/4 DR. 
	3814			6814	



6 PC.

6PC. Impact Adapter Set









786P06

- Square drive adaptor to DIN 3121 / ISO 1174 with ball lock
- Internal square drive to DIN 3121 / ISO 1174
- For machinery usage

1.31 kg / 1 / 20

DIN 3121

Cr-Mo

M	Contents	F	M	Contents	F
3/8 DR.		1/4 DR.	3/8 DR.		1/2 DR. 
	2863P			4863P	
1/4 DR.		3/8 DR. 	3/4 DR.		1/2 DR.
	3862P			4866P	
1/2 DR.		3/8 DR.	1/2 DR.		3/4 DR. 
	3864P			6864P	



6 PC.

NEW

KING TONY

Interchangeable Air Blow Gun Set



7
PC.

- Mini blow gun with 6pcs quick release nozzle tip
- Unique design control airflow output
- Venturi nozzle for produce X2.7 boost air flow
- Flat jet nozzle tip 42mm wide low noise under 85dBA
- 100mm non-scratch nozzle tip
- 100mm steel extension nozzle tip
- Conical rubber nozzle tip allow extension wear
- Safety venting nozzle tip control under 30psi
- Plastic case size (mm) :
207 x 170 x 55 (0.068 cuft)

Mini Air Blow Gun Set

7990A0

KT NO.	Air inlet inch	Working pressure PSI	Temperature range
7990A0	1/4"	90-120	-20°C to 85°C (-4°F to 185°F)

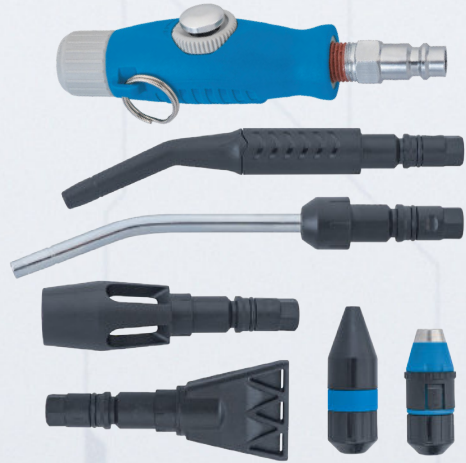

Contents

7990A0-P01(1/4" BSPT)



7990A-P02



7990A-P03



7990A-P04



7990A-P05



7990A-P06



7990A-P07

NEW

KING TONY

Interchangeable Accessories

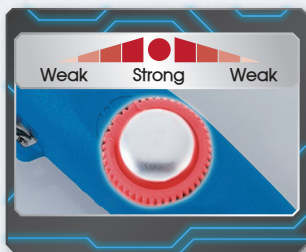

- Airflow adjusting knob (Mini type)

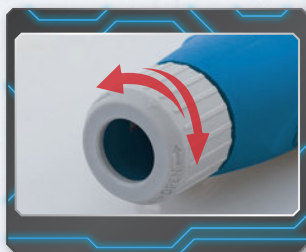

- Quick release



- Multi-angle adjustment for air blow direction (6 different angle, reduce the pressure to your wrist)

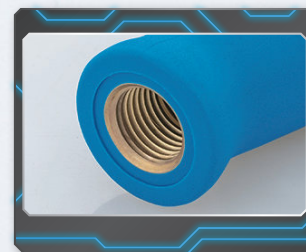

- Brass inlet

Mini Air Blow Gun

7990A0-P01 (1/4" BSPT)



NEW

KING TONY



7990A-P02

- Plastic nozzle
100mm, NY+GF. Ideal for any kind of project, avoid causing damage to object



7990A-P03

- Turbo nozzle
Special structure, increase 270% of airflow



7990A-P04

- Noise reduction nozzle (42mm)
Sound less than 85 Decibel, low noise level



7990A-P05

- Steel nozzle
ø6x100mm



7990A-P06

- Rubber nozzle
Preventing causing damage to object (Use with steel nozzle)



7990A-P07

- Safety venting nozzle
The pressure will be reduced to below 30PSI. It's to make sure the pressure won't cause damage to human body (Use with steel nozzle)

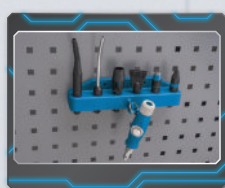

7990A-P08

- Storage rack



Screw Extractor Set

11015SQ

- Ideal tool for removing rounded/damaged/stuck bolts
- Material: 8660 steel
- Hardness: HRC49-52

kg 0.53  1 / 20

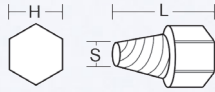

15 PC.

Hex size(H) mm	inch	Size(S) mm	Overall length(L) mm
12	1/8", 3/16", 1/4", 3/8"	3, 4, 5, 5.5, 6, 8, 10	29
16	1/2"	11, 12, 14	

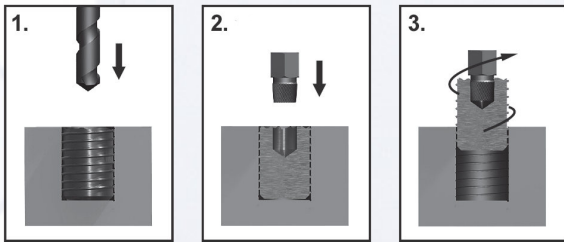

- Operation:
1. Drilling a hole which is 0.5mm bigger than the extractor on the bolt
 2. Insert the extractor in the bolt
 3. Turn counter clockwise to remove the bolt



Note: This is a manual operated tool, do not use with impact or power tools

Pipe Wrench

6522

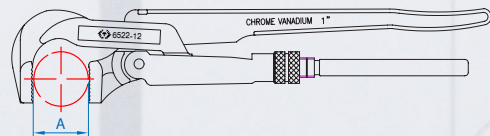
- 90° Angle Clamping Jaws
- I-beam handle design
- Special hardened teeth
- DIN 5234



KT NO.	A mm	Size inch	Overall length			
			inch	mm		
6522-12	45	1-3/4	12-1/2	320	693	1 / 20
6522-16	55	2-3/8	16-1/2	425	1265	1 / 20
6522-22	67	2-15/16	22	560	2210	1 / 10
6522-25	110	4-5/16	24-1/2	630	3000	1 / 4
6522-29	130	5-1/8	29	735	5290	1 / 2

NEW

KING TONY



- Optimized Charging Performance



- 200% Lumen Enhancement



- Significantly Enhanced Protection



6W COB LED & 1W SMD LED Rechargeable Inspection Light

9TA271

- 6W COB LED & 1W SMD LED
- White light color, Kelvin:6500K
- Switch mode:
 - Top light/Main light(low-high)/Off
- Material: Durable ABS+PC+TPE
- Rechargeable battery:3.7V 2600mAh Li-ion battery
- Charging time:3.5hours
- IP54 protection rating
- IK07 vandalproof
- EN62471 Photobiological safety
- Working temperature: -10° C to + 40° C

Switch mode	Lumen	Operating hours
Toplight	120 lm	12h
Main light-low	250 lm	6h
Main light-high	600 lm	3h

600 Lumen

6W

3-12h



Li-ion
2600 mAh
3.7V

TYPE-C
USB

IP54
IK07

3.5h

RoHS



KT NO.

L
mm



9TA271

260

186

1 / 20



• Battery indicator

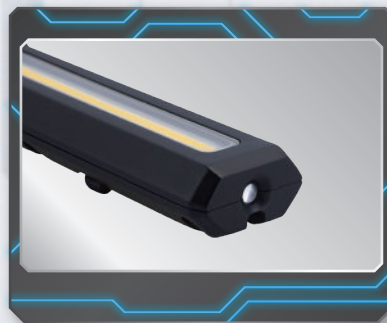

• Top light

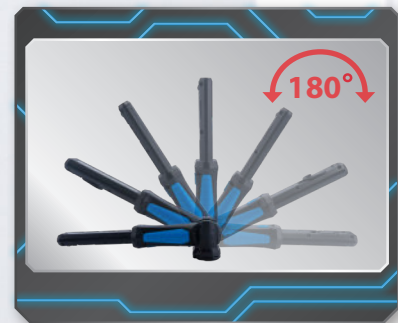

• Top light 180° swivel base with 6 positions



• Ergonomic Handle

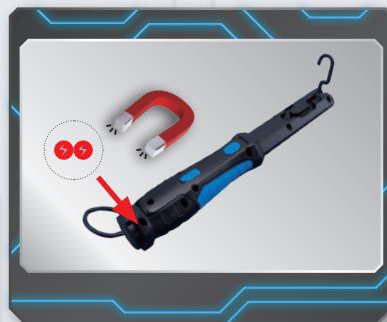

• Strong bottom magnet with two functional hooks

NEW

KING TONY

Ultra Compact Site Light

9TA48

- 30W COB LED
- White light color, kelvin : 6500K
- Rechargeable high quality 7.4V 5200mAh Li-ion
- Quick charging time : 4.5 hours
- Material : Aluminum Body, nylon stand and handle, rubber edge protector

3000 Lumen **30W** **2-25h**
Li-ion 5200mAh 7.4V **4.5h** **IP65 IK07**
CE **RoHS**

Switch mode	Lumen	Operating hours
Work light 20%	300 lm	25h
Work light 40%	750 lm	12h
Work light 60%	1500 lm	6h
Work light 80%	2250 lm	4h
Work light 100%	3000 lm	2h



- Input
- USB output (Power bank)

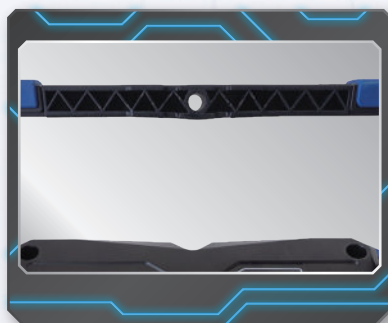

- Option to fixation

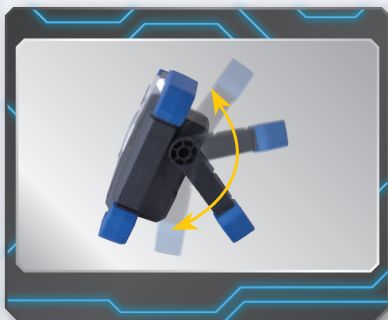

- 180° vertical rotation

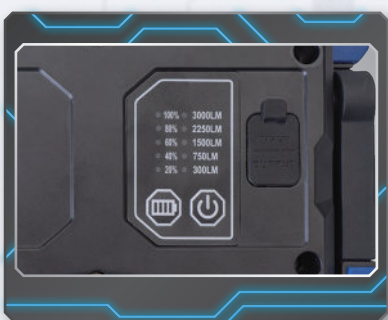

- 5 LED battery level indicators, low power warning



- Tripod mountable (option tripod not included)

KT NO.	Applicable area	L x W x H mm	Icons	Contents	Quantity
9TA48A	Europe	205 x 153 x 75	960 1 / 8	30W floodlight with power bank	x 1 PC.
9TA48B	America & Asia	205 x 153 x 75	960 1 / 8	Type-C USB	x 1 PC.
9TA48D	Australia & New Zealand	205 x 153 x 75	960 1 / 8	5V/2A Charger	

Damaged Nuts Remover Socket Set

CAUTION Can't be used with pneumatic wrench

9TD033MR

1/2"

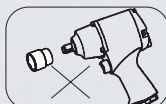

4 PC.

Contents 0.40 4 / 8

9TD403 17, 19, 21

NEW

KING TONY

Oil Filter Chain Wrench

3209

- Suitable for removing all kinds of oil filter on vehicles
- Chain design for easily removing stubborn oil filter

KT NO.	Capacity mm	kg	Box
3209-120	Ø 60~120	302	12 / 48
3209-135	Ø 60~135	333	12 / 48
3209-220	Ø 60~220	385	12 / 36



1/2"



Oil Filter Wrench for HGV Truck

9AE31X

- Oil filter wrench design for high torque requirements
- Use with a 1/2" square drive tool
- Universal tool for HGV truck, bus, tractor and marine engines



KT NO.	Ø Capacity mm	g	Box
9AE31X-120	105~118	500	6 / 24
9AE31X-135	118~130	667	6 / 24
9AE31X-145	130~143	750	6 / 24



- Strong steel band can be more stable on oil filter removal

NEW

KING TONY

Carbide Scraper & Set

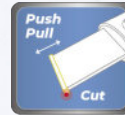

9CJ74

- The blade tip is made of tungsten carbide material, which offers high hardness and a long lifespan. Available in 16mm and 32mm width.
- It can be used to scrape off residual carbon deposits, rust marks, or silicone residue from surfaces of objects, such as old silicone on oil sumps, exhaust manifolds, or brake calipers.
- The blade tip is equipped with a protective cover, and the rear end has a hanging hole.



KT NO.	A mm	inch	L mm		
9CJ7416	16	8	210	136	10 / 40

KT NO.	A mm	inch	L mm		
9CJ7432	32	8	210	165	10 / 40

9CJ072

KT NO.		
9CJ072	301	10 / 40

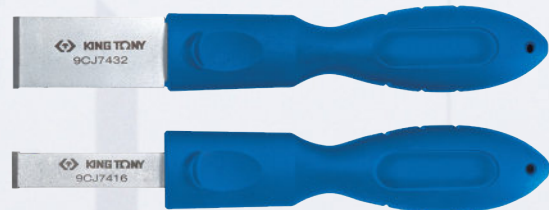

• Scrape off glue.



• Scrape off rust.



- The blade tip has been finely ground on all four sides, allowing for both pushing and pulling motions.



- Designed with ergonomic handle to conform to human ergonomics, providing a comfortable grip.

NEW

KING TONY

Signage for Display Stand

ADVT-03X

- Size: 960x55(mm)
- Magnet



	Impact Sockets		ADVT-031
	Hand Sockets		ADVT-032
	Wrenches		ADVT-033
	Hand Sockets & Accessories		ADVT-034
	Torque Wrenches		ADVT-035
	Pliers & Strippers & Cutters		ADVT-036
	VDE Insulated Tools		ADVT-037
	Power Driving Tools		ADVT-038
	KING TONY		ADVT-039

Side Panel for Display Stand

ADVT-04

ADVT-05

- Size: 240x900(mm)



ADVT-04

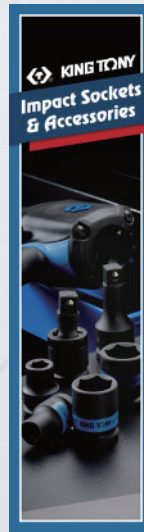
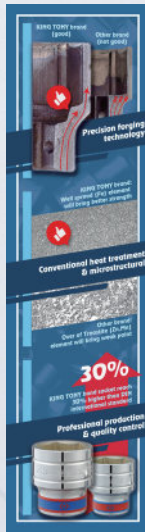

ADVT-05

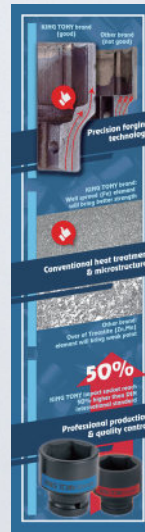

NEW

KING TONY

Personal Cooler Bag

ZS120-S

- Size : 290 x 150 x 210 mm
- Weight : 352g



Door mat

ZS417

- Size : 600 x 900 x 8mm PVC



Cutting Mat

ZS418K

- Size : 700 x 500 x 3 mm

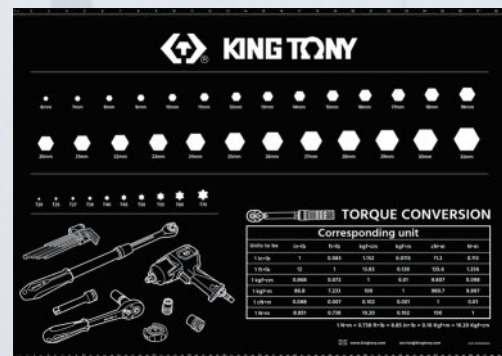

Mug

ZS606

- Capacity:550ml

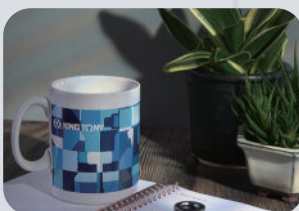

NEW

KING TONY

TOOLS STORAGE & TOOLS SYSTEM SETS







OBJECT-ORIENTED ORGANIZATION

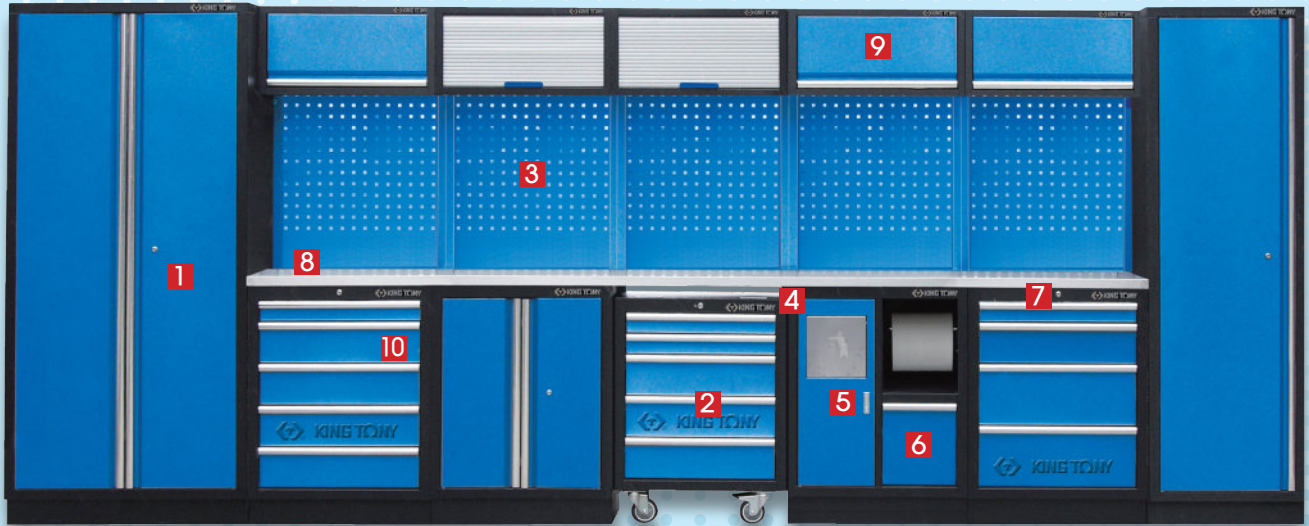

1 Flexible / adjustable shelves



2 Ball bearing slides

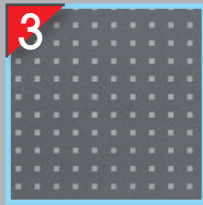

3 Steel panel for tool storage



4 Concealed handle



5 Hidden knob



6 Double volume



7 Front centralized locks



8 Stainless steel work surface



9 Cupboard with gas spring



10 The drawer with capacity 30kg



OBJECT-ORIENTED ORGANIZATION



87D11X01SA-KG

Overall: 4885 x 460 x 2000 mm

462.23 CUFT 116.75



87D11X01SA-KB

Overall: 4885 x 460 x 2000 mm

462.23 CUFT 116.75





OBJECT-ORIENTED ORGANIZATION

87D11X02SA-KG

Overall: 4235 x 460 x 2000 mm

400.87 kg CUFT 100.23



87D11X02SA-KB

Overall: 4235 x 460 x 2000 mm

400.87 kg CUFT 100.23





OBJECT-ORIENTED ORGANIZATION



87D11X03A-KG

Overall: 2955 x 460 x 2000 mm

262.26 CUFT 71.39



87D11X03A-KB

Overall: 2955 x 460 x 2000 mm

262.26 CUFT 71.39





OBJECT-ORIENTED ORGANIZATION

87D11X04A-KG

Overall: 2640 x 460 x 2000 mm

⚖️ 248.60 CUFT 64.91



87D11X04A-KB

Overall: 2640 x 460 x 2000 mm

⚖️ 248.60 CUFT 64.91

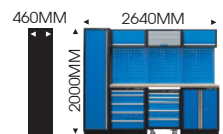

87D11X05A-KG

Overall: 2275 x 460 x 2000 mm

⚖️ 202.50 CUFT 51.83



87D11X05A-KB

Overall: 2275 x 460 x 2000 mm

⚖️ 202.50 CUFT 51.83





OBJECT-ORIENTED ORGANIZATION



87D11A-KG

Overall: 3920 x 460 x 2000 mm

KG 351.57 CUFT 89.35



87D11A-KB

Overall: 3920 x 460 x 2000 mm

KG 351.57 CUFT 89.35

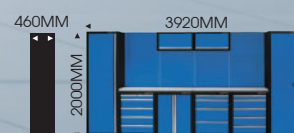



OBJECT-ORIENTED ORGANIZATION ACCESSORIES

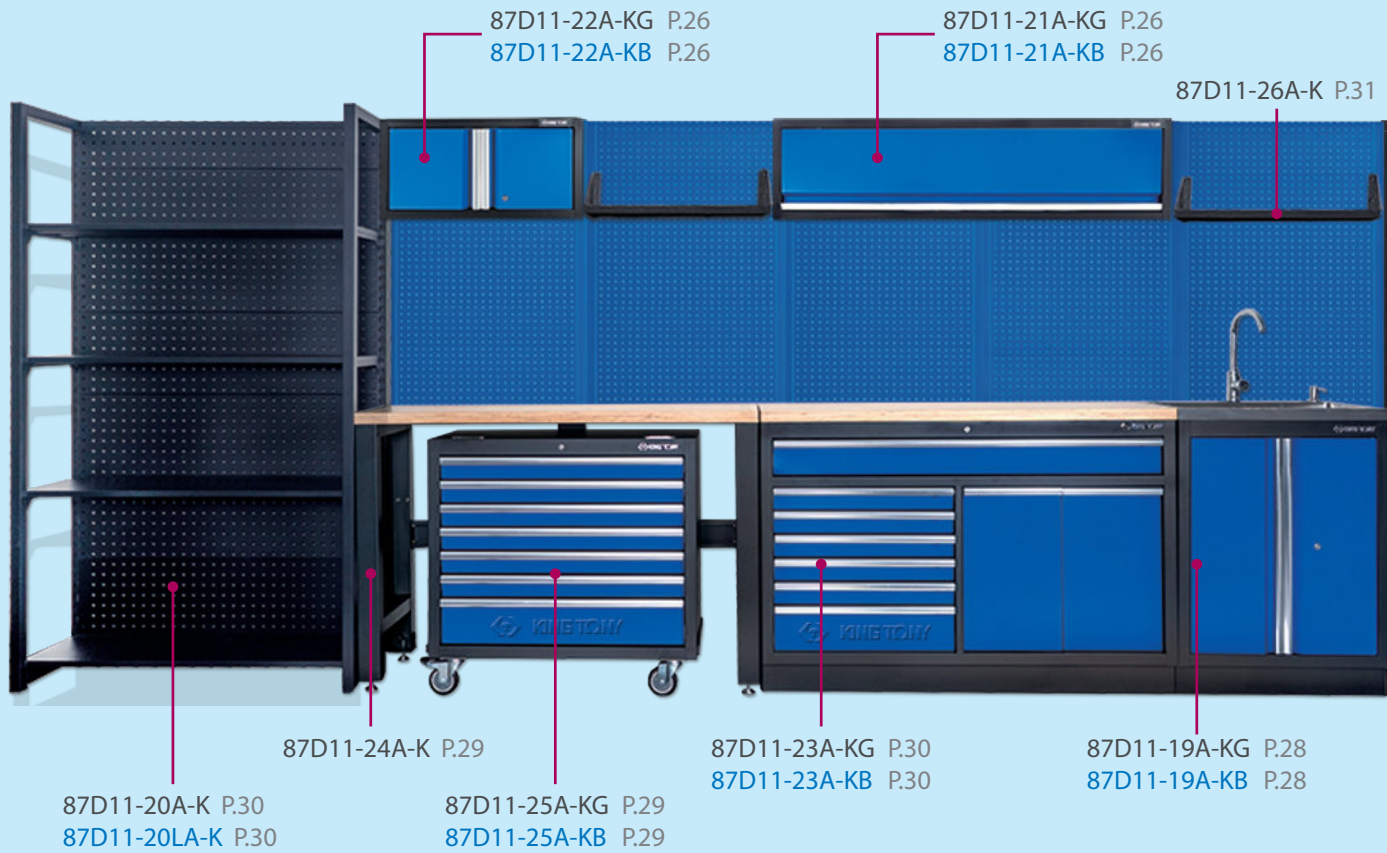

Tall Cabinet

87D11-02A-KG

87D11-02A-KB



KT NO.	Overall (mm)	Kg	CUFT
87D11-02A-KG	600 x 460 x 2000	53	9.28
87D11-02A-KB			

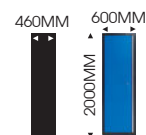

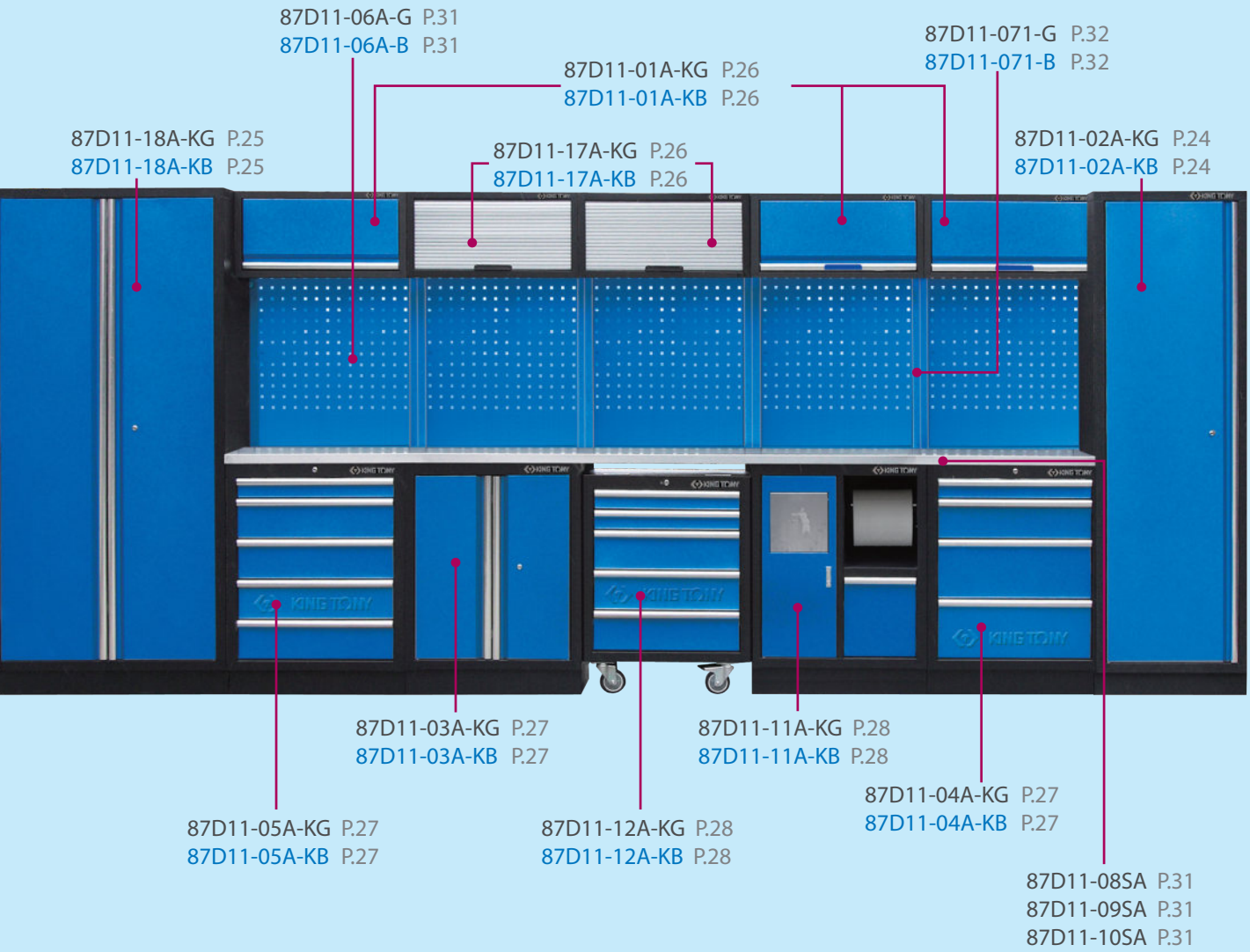

Tall Cabinet

87D11-18A-KG

87D11-18A-KB



87D11-18A-KG



87D11-18A-KB

KT NO.	Overall (mm)		CUFT
87D11-18A-KG	915 x 460 x 2000	78	12.72
87D11-18A-KB			

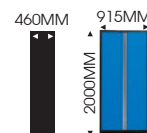



Extra Wide Wall Cabinet

87D11-21A-KG



87D11-21A-KG

KT NO.	Overall (mm)	Kg	CUFT
87D11-21A-KG 87D11-21A-KB	1360 x 281 x 350	17	7.24

87D11-21A-KB



87D11-21A-KB

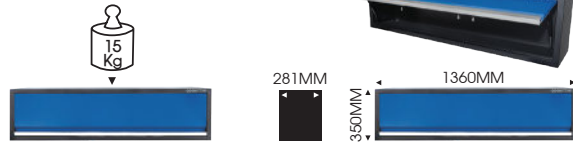

Wall Cabinet

87D11-01A-KG



87D11-01A-KG



87D11-17A-KG



87D11-22A-KG

Rolling Shutter

87D11-01A-KB



87D11-01A-KB



87D11-17A-KB



87D11-22A-KB

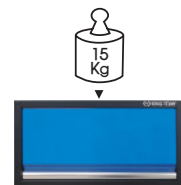
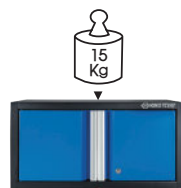

KT NO.	Overall (mm)	Kg	CUFT
87D11-01A-KG 87D11-01A-KB	680 x 280 x 350	10.0	3.73
87D11-17A-KG 87D11-17A-KB		8.4	
87D11-22A-KG 87D11-22A-KB		9	



Opened Door Cabinet

87D11-03A-KG





87D11-03A-KG

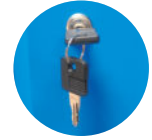
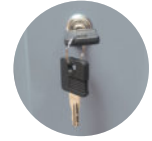

87D11-03A-KB

87D11-03A-KB



KT NO.	Overall (mm)		CUFT
87D11-03A-KG	680 x 460 x 910	28.5	13.58
87D11-03A-KB			

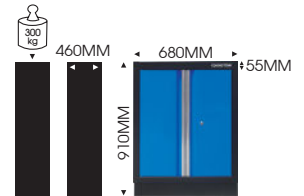

Drawer Cabinet

87D11-04A-KG



87D11-04A-KG



87D11-04A-KB

87D11-05A-KG



87D11-05A-KG



87D11-05A-KB

KT NO.	Spec.	Overall (mm)		CUFT
87D11-04A-KG	4 Drawer	680 x 460 x 910	46.70	13.58
87D11-04A-KB				
87D11-05A-KG	5 Drawer	680 x 460 x 910	49.30	13.58
87D11-05A-KB				

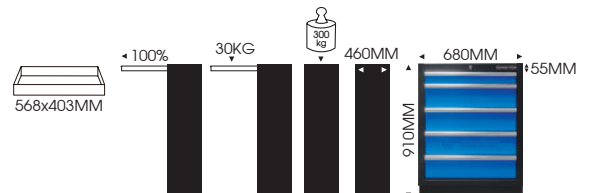



Trash Bin With Paper Holder

87D11-11A-KG

87D11-11A-KB



87D11-11A-KG

87D11-11A-KB

KT NO.	Overall (mm)	Kg	CUFT
87D11-11A-KG	680 x 460 x 910	35.20	13.58
87D11-11A-KB			

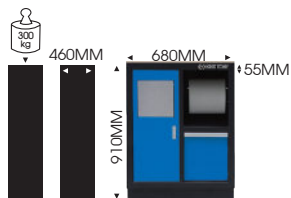

5 Drawers Cabinet

87D11-12A-KG

87D11-12A-KB

- Four swivel casters (one with brake mechanism)



87D11-12A-KG

87D11-12A-KB

KT NO.	Spec.	Overall (mm)	Kg	CUFT
87D11-12A-KG	5 Drawer	650 x 460 x 862	46	10.41
87D11-12A-KB				

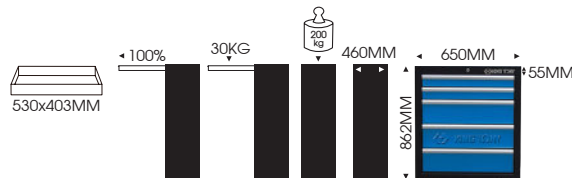

Washbasin Cabinet

87D11-19A-KG

87D11-19A-KB

- Water tap & Stainless steel sink, easy to clean
- Convenient two door cabinet



87D11-19A-KG



87D11-19A-KB

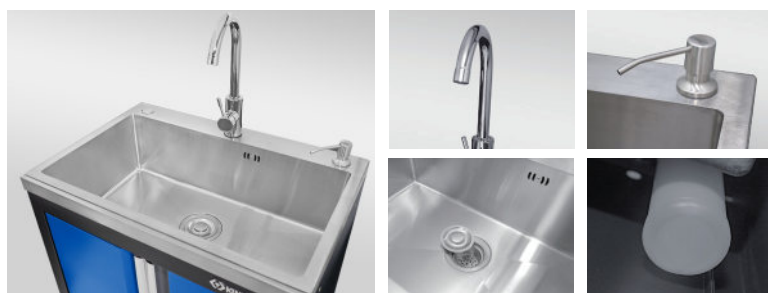

KT NO.	Overall (mm)	Kg	CUFT
87D11-19A-KG	680 x 464 x 948	33	14.23
87D11-19A-KB			

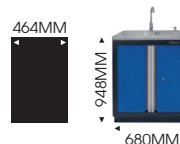



Workbench Frame

87D11-24A-K

- Workbench frame is able to combine with tool cabinet 87D11-25A-KG
- Suitable for use with workbench table(87D11-08A)

The workbench table is not included ✘

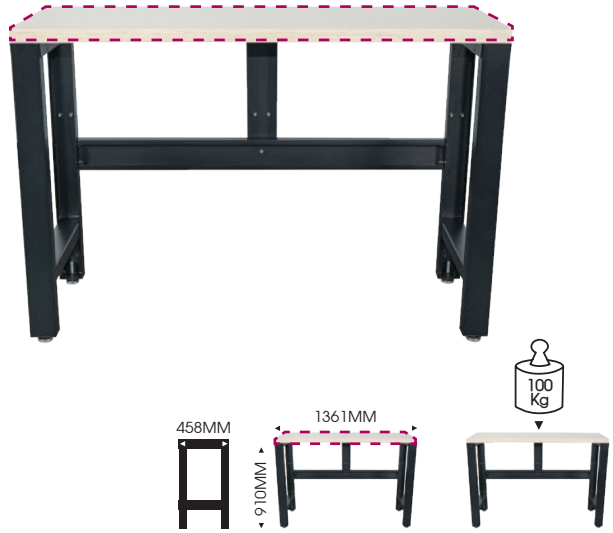

KT NO.	Overall (mm)	KG	CUFT
87D11-24A-K	1361 x 458 x 910	19.5	4.22

7 Drawer Tool Cabinet With Casters

87D11-25A-KG

- Suitable for use with workbench 87D11-24A-K
- 35in wide drawer, increasing the storage space
- Four swivel casters(one is with brake mechanism)

87D11-25A-KB



87D11-25A-KG



87D11-25A-KB

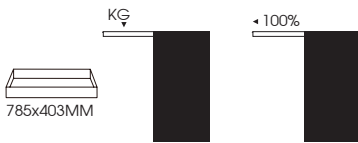

KT NO.	Spec.	Overall (mm)	KG	CUFT
87D11-25A-KG 87D11-25A-KB	Overall	895 x 460 x 732	65	14.07
	1 Drawer	785 x 403 x 137		
	6 Drawer	785 x 403 x 58		

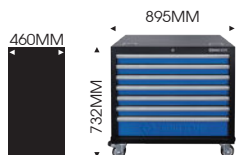

• The groove design is easy to pull out the cabinet



9 Drawer Bottom Cabinet

87D11-23A-KG

87D11-23A-KB

- 53 inch wide cabinet, with one wide drawer, six drawers, two big drawer
- Content with garage bin & storage box*18 PC.



87D11-23A-KG



87D11-23A-KB

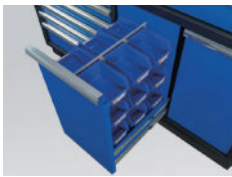

• Storage box

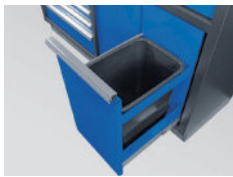

• Garage bin



• Safety mechanism

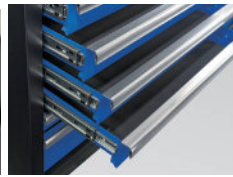

KT NO.	Spec.	Overall (mm)	Kg	CUFT
	Overall	1360 x 465 x 948	112	29.77
87D11-23A-KG	1 Drawer	1272 x 403 x 84		
87D11-23A-KB	5 Drawers	783 x 403 x 58		
	1 Drawer	783 x 403 x 137		
	2 door	284 x 371 x 531		

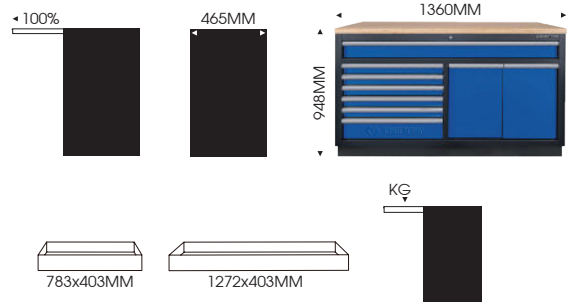

Storage Shelves

87D11-20A-K

87D11-20LA-K

- Multi-layer to storage
- Suitable for combine with 87D11 tool cabinet system



87D11-20A-K



87D11-20LA-K

KT NO.	Overall (mm)	Kg	CUFT
87D11-20A-K	680 x 458 x 2000	41	5.94
87D11-20LA-K	1200 x 458 x 2000	55	5.94

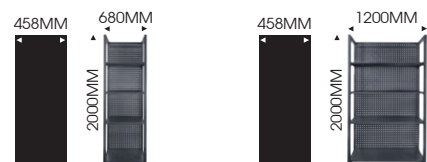



Storage Shelves

87D11-26A-K

- Wall tray for back panel, easy to storage

KT NO.	Overall (mm)			CUFT
87D11-26A-K	602 x 281 x 178	2.6	1 / 4	1.71

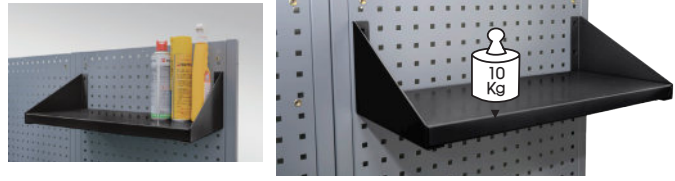

Pressed Wooden Board

87D11-08A

KT NO.	Overall (mm)	CUFT
87D11-08A	1360 x 465 x 38	12.5
87D11-09A	2042 x 465 x 38	19.0
87D11-10A	681 x 463 x 38	6.0

87D11-09A

87D11-10A



Stainless Board

87D11-08SA

KT NO.	Overall (mm)		CUFT
87D11-08SA	1360 x 465 x 38	21.0	1.61
87D11-09SA	2042 x 465 x 38	31.80	2.39
87D11-10SA	681 x 463 x 38	10.50	0.81

87D11-09SA

87D11-10SA



Back Panel

87D11-06A-G

KT NO.	Overall (mm)		CUFT
87D11-06A-G	615 x 25 x 1052	5.3	1.13
87D11-06A-B			

87D11-06A-B

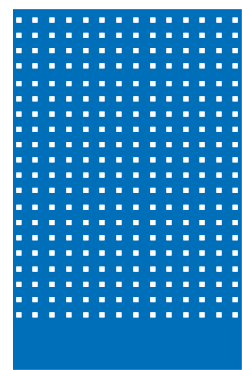
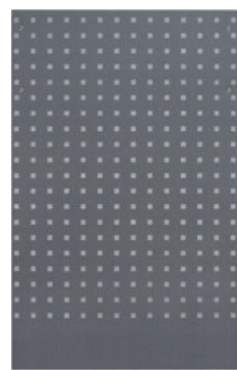
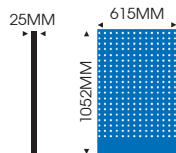

87D11-06A-G

87D11-06A-B



Pillar

87D11-071A-G

87D11-071A-B

KT NO.	Overall (mm)	KG	CUFT
87D11-071A-G	33 x 30 x 1420	1.5	0.13
87D11-071A-B			

87D11-071A-B

87D11-071A-G

Optional accessories

87D11X06SA-KG

87D11X06A-KG

87D11X06SA-KB

87D11X06A-KB

Corner Bottom Cabinet

87D11-13A-KG

87D11-13A-KB



KT NO.	Overall (mm)	KG	CUFT
87D11-13A-KG	865 x 865 x 910	42	7.06
87D11-13A-KB			

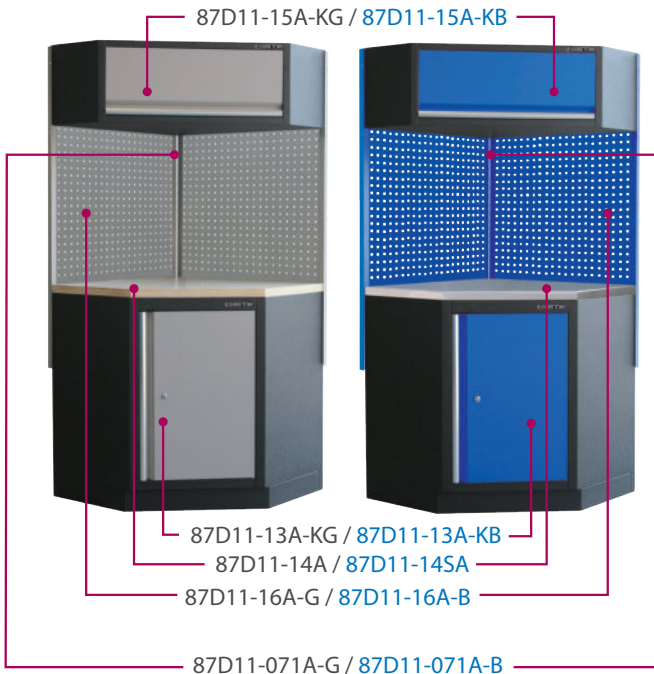
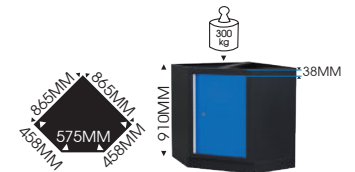

Corner Wall Cabinet

87D11-15A-KG

87D11-15A-KB

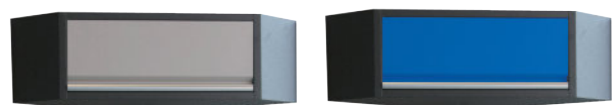

KT NO.	Overall (mm)	KG	CUFT
87D11-15A-KG	865 x 865 x 350	21	12.70
87D11-15A-KB			

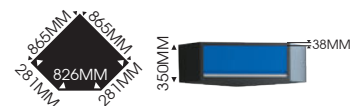



Stainless Steel Board

87D11-14SA



KT NO.	Overall (mm)	Kg	CUFT
87D11-14SA	865 x 865 x 38	19	1.94

Pressed Wooden Board

87D11-14A



KT NO.	Overall (mm)	Kg	CUFT
87D11-14A	865 x 865 x 38	13	1.94

Corner Back Panel

87D11-16A-G

87D11-16A-B

KT NO.	Overall (mm)	Kg	CUFT
87D11-16A-G 87D11-16A-B	800 x 25 x 1052	6.95	1.45

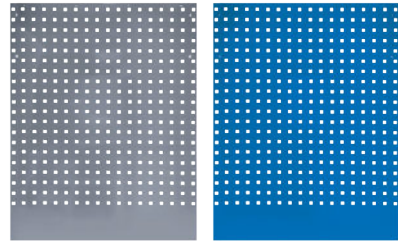
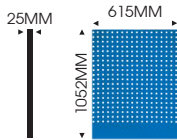

Adjusting Feet

KT NO.	Contents	Kg
87D11-05A-10	<ul style="list-style-type: none"> ▪ Pack by 4 PC. 	700

Hook

KT NO.	Contents	Kg
87E02-051A	<ul style="list-style-type: none"> ▪ 1" Single hook ▪ Pack by 10 PC. 	20
87E02-053A	<ul style="list-style-type: none"> ▪ 3" extra long single hook ▪ Pack by 10 PC. 	30
87E02-061A	<ul style="list-style-type: none"> ▪ 1" Double hook ▪ Pack by 10 PC. 	50
87E02-063A	<ul style="list-style-type: none"> ▪ 3" extra long double hook ▪ Pack by 10 PC. 	68



Tool Trolley

KT NO.	Loading 	Wheel 	Work top 	Drawers 	100% Open 	Risk-free 	Bumper 	Auto-return 	INDEX
--------	-------------	-----------	--------------	-------------	---------------	---------------	------------	-----------------	-----------

L	87432-B	360	5"X1-1/4"	Cutting mat	5 / 7	●	X	-	-	P.37
	87434-B	360	5"X1-1/4"	Cutting mat	5 / 7	●	X	-	-	P.37
	87432-G	680	5"X2"	Cutting mat	5 / 7	●	●	-	●	P.37
	87434-G	680	5"X2"	Cutting mat	5 / 7	●	●	-	●	P.37
	87634	360	5"X1-1/4"	Cutting mat	7	●	-	●	-	P.38
	87G31	500	5"X2"	Steel	6 / 7	●	-	●	●	P.40
	87G38	400	5"X2"	PVC multil-f	6 / 7	●	-	-	-	P.39
	87SQ31	500	5"X2"	Stainless	6 / 7 / 8	●	●	●	●	N5
XL	87SQ32	700	5"X2"	Stainless	6 / 7 / 8	●	●	●	●	N6
	87SQ33	700	5"X2"	Stainless	6 / 7 / 8	●	●	●	●	N6
XXL	87435	600	6"X2"	Cutting mat	13	●	-	-	-	P.38
SV	87SQ34	700	5"X2"	Wooden	10	●	●	●	●	N8
	87441	540	4"X1-1/4"	Cutting mat	1 / 3	●	-	-	-	P.43
	87446	600	4"X1-1/4"	Cutting mat	3	●	-	-	-	P.44
	87G41	150	4"X1"	PVC multil-f	-	-	-	-	-	P.40



Customized Color Choice Chart



8743X-XB-B

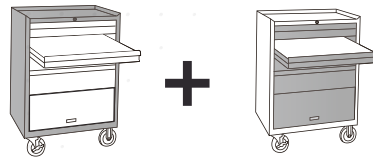

		-RK	
		-B	
		-BK	
		-K	
		-G	
		-OK	

(Other colors are optional, produce with minimum quantity)

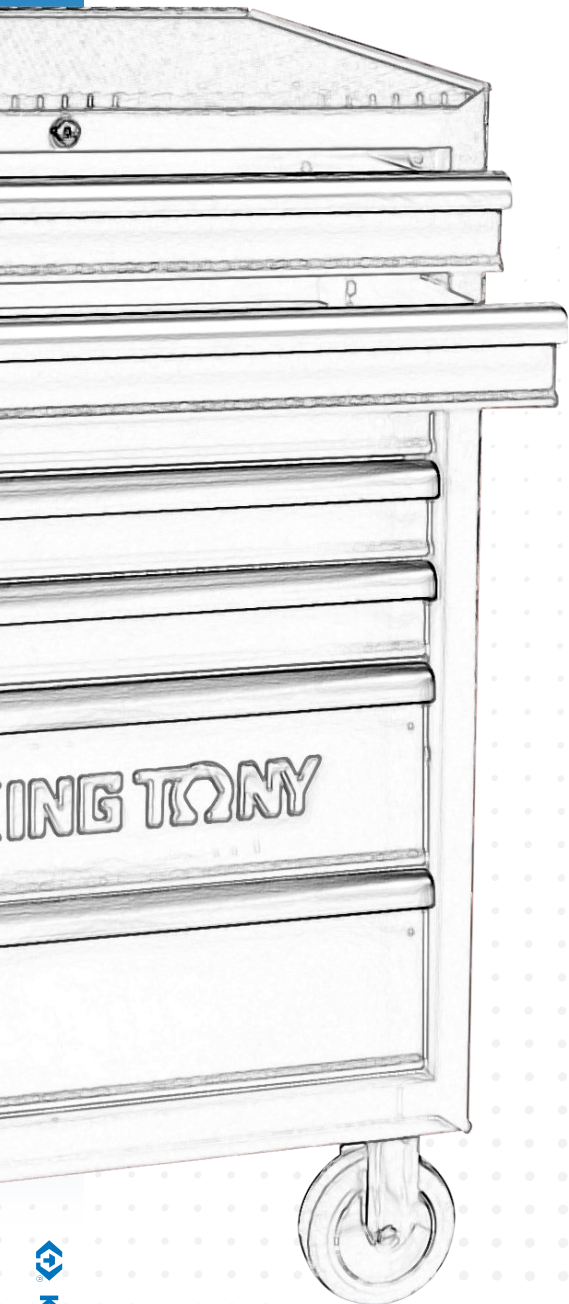

Load bearing



- Overall supporting weight for tool trolley at a safety level



- Overall supporting weight for drawers at a safety level

Convenient



- Convenient and safety with Central lock system



- 100% drawer opening, does not interfere with the removal of tools



- 360° swivel wheel with brake function



- The size of the drawer conforms to TCS, and the tool set can be purchased freely according to the demand

Robustness



- Body frame are constructed with one-piece steel sheet for integral strength



- The bottom of the drawers are stamped in order to strengthen effectively

Protection



- Protection bumpers are for to avoid collisions and to protect object during maneuver



- Risk Free System (RFS) allows open one drawer at a time which prevents the loss of center of gravity from tilting and instability



- Press to open drawer is a safe and reliable system

Features



• 100% open ball bearing slide for drawer



• Industrial TPR floor brake casters



• One piece steel body



• Central locking system + 10mm top mat



• Embossed & hammed edge drawer increase strength



• Add strength and safety

Tool Trolley

(Other colors are optional, produce with minimum quantity)



87432-5B



87434-7B



87432-5G



87434-7G

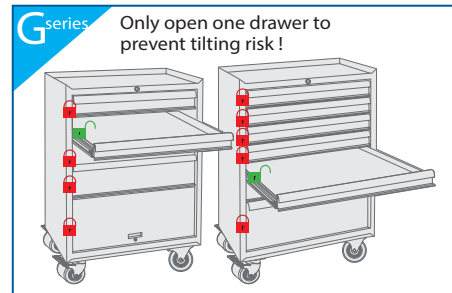
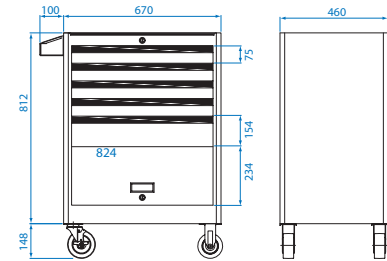

KT NO.	Spec.	Dimension(mm) Width x Depth x Height	Casters	Static load	KG	CUFT
87432-5B	4 Drawer	576 x 380 x 75	5"x1-1/4"	360 Kg	56	12.24
	1 Drawer	576 x 380 x 154				
	Bulk Drawer	603 x 404 x 234				
87434-7B	5 Drawer	576 x 380 x 75	5" x 2"	680 Kg	56	
	2 Drawer	576 x 380 x 154				
87432-5G	4 Drawer	576 x 380 x 75	5" x 2"	680 Kg	56	
	1 Drawer	576 x 380 x 154				
87434-7G	Bulk Drawer	603 x 404 x 234	5" x 2"	680 Kg	64	
	5 Drawer	576 x 380 x 75				
	2 Drawer	576 x 380 x 154				



Classic Bumper Type Tool Trolley

87634-7B

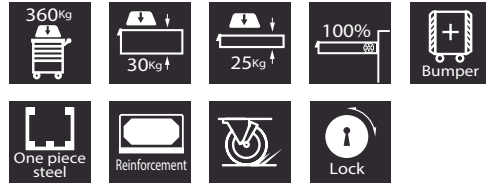

- Soft bumpers each side avoids scratch or damage vehicle
- More space for bottles & hanging
- Easily move two side handle bar & industrial TPR casters
- 100% pull out ball bearing drawer
- One piece steel for heavy load structure
- Central locking system + 10mm top mat

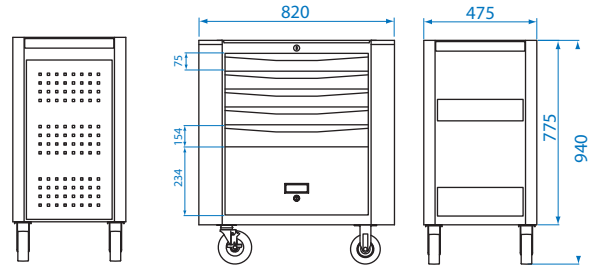

KT NO.	Spec.	Dimension(mm) Width x Depth x Height	Casters	Static load		CUFT
87634-7B	5 Drawer	576 x 380 x 75	5" x 1-1/4"	360 Kg	66.14	15.64
	2 Drawer	576 x 380 x 154				

Tool Trolley

87435-13B

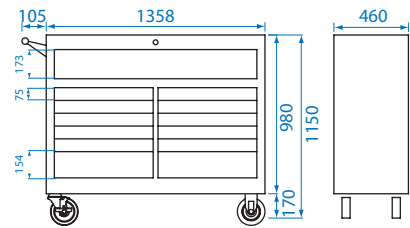
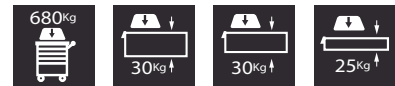

KT NO.	Spec.	Dimension(mm) Width x Depth x Height	Casters	Static load		CUFT
87435-13B	10 Drawer	576 x 380 x 75	6" x 2"	600 Kg	166	31.54
	2 Drawer	576 x 380 x 154				
	1 Drawer	1215 x 390 x 173				

Features



• Trash can hook



• Side compartment



• Industrial TPR floor swivel casters



• Multi-functional working top

Tool Trolley

87G38-7B-K



- Magnetic drawer closures
- Multi-functional working top
- Side locking system

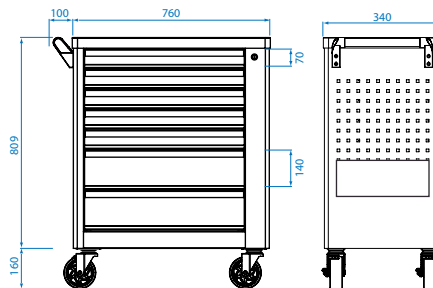

KT NO.	Spec.	Dimension(mm) Width x Depth x Height	Casters	Static load		CUFT
87G38-7B-K	Overall	752 x 450 x 807	5" x 2"	400 Kg	58	13.19
	Overall+4 Casters	752 x 450 x 982				
	5 Drawers 2 Drawers	570 x 380 x 70 570 x 380 x 140				





Features



• Side handle bar



• Flat side panel



• Top platform



• Industrial TPR floor brakes casters



• Garbage bin

Heavy Duty Tool Trolley & Chest



87G31-7B-BK

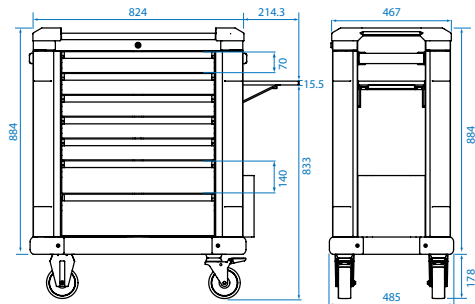

KT NO.	Spec.	Dimension(mm) Width x Depth x Height	Casters	Static load		CUFT
87G31-7B-BK	Overall	824 x 485 x 884	5" x 2"	500 Kg	75.00	16.85
	Overall + 4 Casters	824 x 485 x 1062				
	5 Drawers	575 x 410 x 70				
	1 Drawers	575 x 410 x 110				
	1 Drawers	575 x 410 x 140				

Heavy Duty Tool Trolley & Chest

87G11-4B-BK

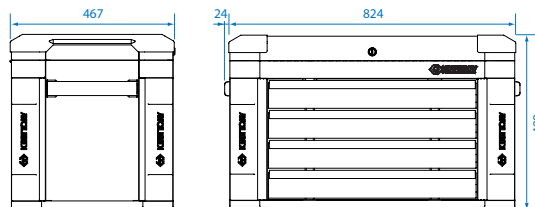

KT NO.	Spec.	Dimension(mm) Width x Depth x Height		Kg	CUFT
		87G11-4B-BK	Overall 4 Drawers		

87G001DQ-BK (include 87G11-4B-BK + 87G31-7B-BK)



- 4 drawers top chest + 7 drawers tool trolley
- ABS corner protection bumpers avoids damaging vehicle
- 100% pull out ball bearing drawer with auto-return system
- Heavy duty ball bearing sides, 35kgs capacity for each drawer
- Top chest lid with hydraulic bars
- With side tray and garbage bin
- Internally welded joints for durability

KT NO.	Spec.	Dimension(mm) Width x Depth x Height		Casters	Static load	Kg	CUFT
		87G001DQ-BK	Overall Overall +4 Casters				





Accessory

87432-15

- Plastic top mat
- Size : 920(W) x 490(D) x 50(H)mm



84087637BKT

- Plastic mat
- Size : 665(W) x 455(H) x 19(D) mm



87432-31

- Side handle bar
- Size : (Ø)38.5 x 457(L) mm



87432-32

- Can holder



87432-52

- Paper holder
- Size(H x L x D) : 45 x 290 x 65 mm

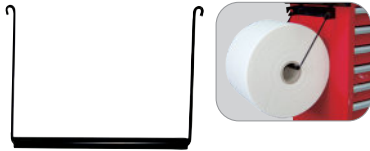

87432-17

- Flat side panel
- Size : 456 x 370mm



87432-23



87432-24



KT NO.	Frame(mm) Width x Depth x Height	Material	Divider Size mm
87432-23	574 x 358 x 40	Steel	Long: 560x40(2PC.) Short: 368x40(2PC.)
87432-24	-	Plastic	Long: 570x40(3PC.) Short: 375x40(3PC.)

87432-33

- Magnetic tool holder
- Size : 458 x 52 x 17mm



87432-34

- Bottle side holder



87432-41

- Work panel
- Size : 656(W) x 500(H) x 30(D) mm

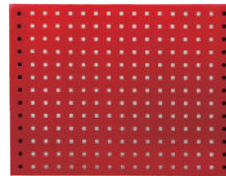

CAUTION Can't install side tray(87432-32) at the same time

Tool Trolley



87441-1B

- 1 drawer trolley
- Two 3.5" deep trays are positioned for convenience



87441-3B

- 3 drawer trolley
- 2 PC. protective mat for top and bottom shelves
- 3 PC. protective drawer liners

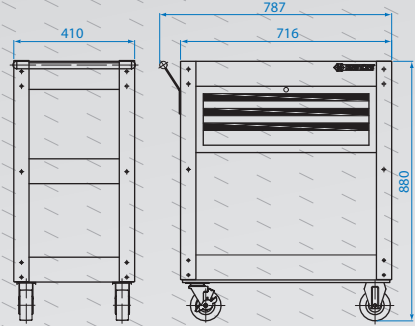

87G41-B

- With multi-functional working top
- 4" x 1" Heavy duty casters (2 Fixed and 2 swivel with stop function)

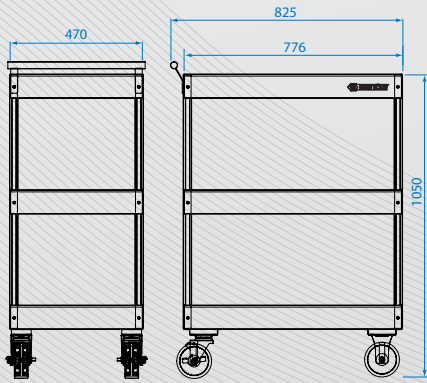

KT NO.	Spec.	Dimension(mm) Width x Depth x Height	Casters	Static load		CUFT
87441-1B	overall	716 x 410 x 750	4" x 1-1/4"	540 Kg	23.2	2.7
	overall + 4" x 1-1/4" Casters	716 x 410 x 880				
	1 Drawer	569 x 275 x 75				
87441-3B	overall	716 x 410 x 750	4" x 1-1/4"	540 Kg	33.0	4.95
	overall + 4" x 1-1/4" Casters	716 x 410 x 880				
	1 Drawer	569 x 275 x 75				
	2 Drawer	569 x 275 x 50				
87G41-B	Overall	776 x 470 x 900	4" x 1"	150 Kg	23.0	3.67
	Overall + 4 Casters	776 x 470 x 1050				





Tool Trolley

- 3 drawer trolley
- 2 PC. protective mat for top and bottom shelves
- 3 PC. protective drawer liners

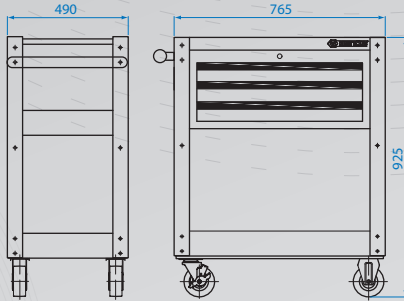









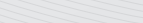

▪ Multiple space bar to hold other tools



KT NO.	Spec.	Dimension(mm) Width x Depth x Height	Casters	Static load		CUFT
87446-3B-KR	overall	765 x 490 x 760	5"x1-1/4"	600 Kg	38	13
	overall + 5"x1-1/4" Casters	765 x 490 x 925				
87446-3B-KB	3 Drawer	576 x 380 x 75				

Accessory

KT NO.	Contents
87502-01	 Tool holder 500mmL
87502-02	 Magnetic tool holder for workbench backpanel Size : 458 x 52 x 17mm
87502-050	 U Shape hook
87502-051	 1" Shape hook
87502-054	 4" Shape hook
87502-058	 8" Shape hook
87502-061	 1" Double hook
87502-064	 4" Double hook
87502-068	 8" Double hook
87502-11	 <ul style="list-style-type: none"> ▪ Cutting board ▪ Oil-resistant, acid-resistant, moisture-resistant and anti-static ▪ 10mm PP foaming board
87502-12	 <ul style="list-style-type: none"> ▪ 4 PC. Adjusting device ▪ Includes adjustable bolt & adjustable pad



Roller Seat

Material: PVC leather + foam cushion + finishing powder coating steel

Two Open Storage Areas



KT NO.	Dimension(mm) Width x Depth x Height			CUFT
87452B-B	350 x 260 x 240	6.4	1 / 1	0.49
87452C-B		6.3	1 / 1	

87C34-3B-B

- Material : PVC leather + foam cushion + finishing powder coating steel
- 3 ball bearing drawers : 274 x 148 x 35 mm
- 3 bottle side holder



KT NO.	Dimension(mm) Width x Depth x Height			CUFT
87C34-3B-B	370 x 400 x 365	8.8	1	2.43



Workbench

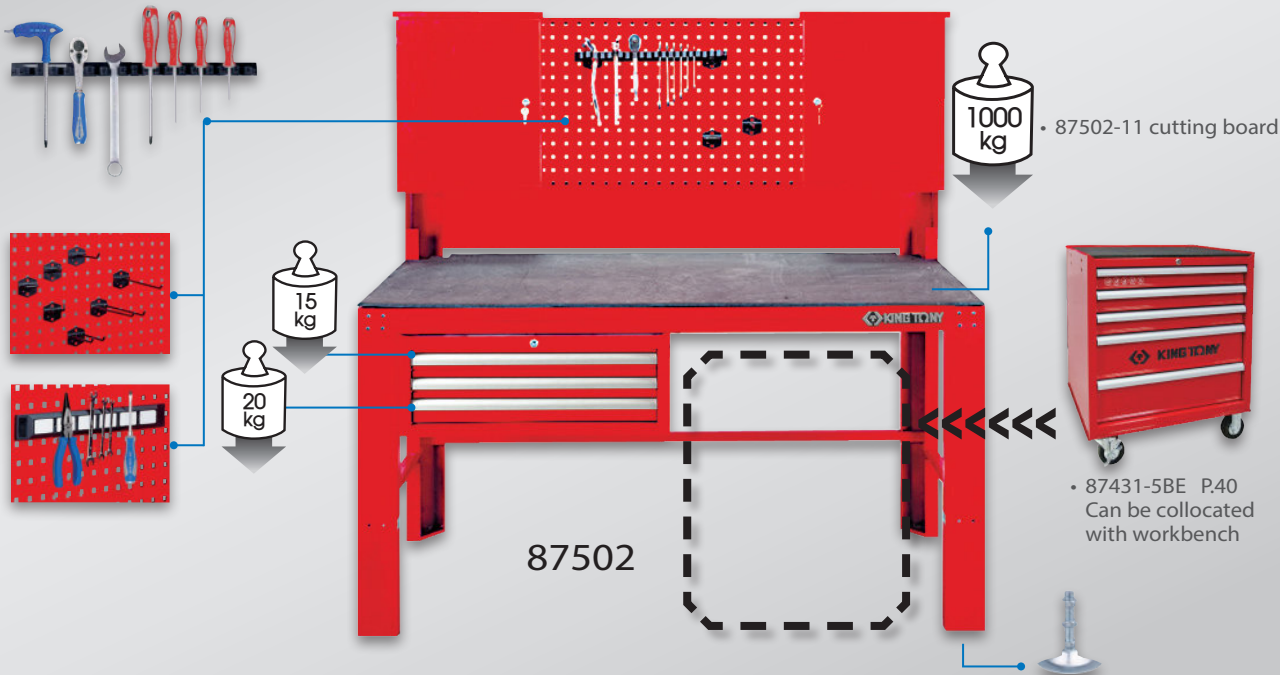

87431-5BE

- Four swivel casters(one is with brake mechanism)

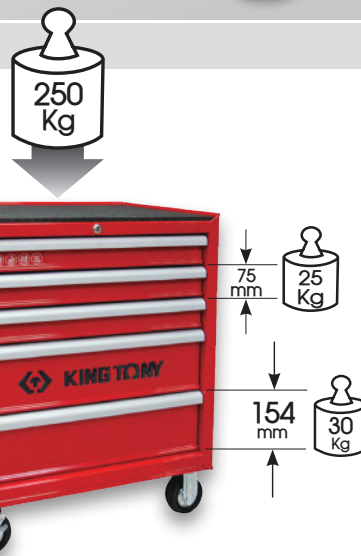
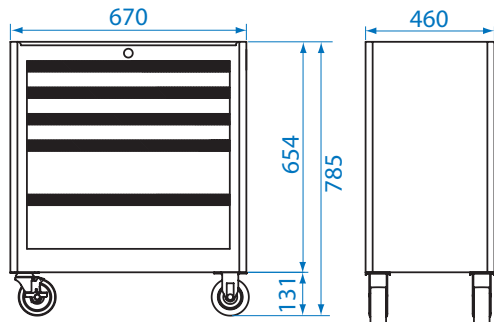

KT NO.	Spec.	Dimension(mm) Width x Depth x Height	Casters	Static load		CUFT
87431-5BE	3 Drawer	576 x 380 x 75	4" x 1-1/4"	250 Kg	50	10.03
	2 Drawer	576 x 380 x 154				

87502P02

- Drawer chest for workbench



KT NO.	Spec.	Dimension(mm) Width x Depth x Height		CUFT
87502P02	Overall	660 x 307 x 251	13.00	2.7
	2 Drawer	569 x 275 x 50		
	1 Drawer	569 x 275 x 75		

87502P03





- 2 PC. wall cabinets

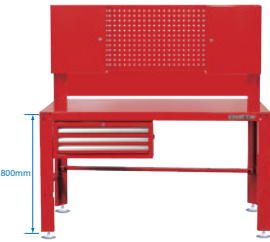

KT NO.	Spec.	Dimension(mm) Width x Depth x Height		CUFT
87502P03	Overall	400 x 200 x 500	14.00	4.5

Workbench

• Workbench excludes cutting board & tool holder

KT NO.		Spec.	Dimension(mm) Width x Depth x Height	Kg	CUFT	
87502		<ul style="list-style-type: none"> 3 drawer chest-ball bearing slide 2 wall cabinets 	Overall	1525 x 700 x 1520	86.00	13.4
			3 Drawer chest	660 x 307 x 251		
			2 Drawer	569 x 275 x 50		
			1 Drawer	569 x 275 x 75		
			Wall cabinet	400 x 200 x 500		
87502P01		<ul style="list-style-type: none"> Workbench with back panel 	Overall	1525 x 700 x 1520	59.00	6.5
87502P011		<ul style="list-style-type: none"> Workbench 	Overall	1525 x 700 x 800	48.00	6.5
87502P012		<ul style="list-style-type: none"> Back panel 	Overall	1525 x 20 x 700	13.50	2.7

87512

KT NO.		Spec.	Dimension(mm) Width x Depth x Height	Kg	CUFT	
87512		<ul style="list-style-type: none"> 3 drawer chest ball bearing slide 1 wall cabinet 	Overall	1565 x 766 x 1403	130.10	21.19
			3 Drawer chest	668 x 313 x 270		
			2 Drawer	568 x 262 x 50		
			1 Drawer	568 x 262 x 75		
			Wall cabinet	1565 x 203 x 603		

Wall Mounted Type Tool Cabinet

87201

- With 20 PC. hooks
 - 5 PC. U shape hook (87502-050)
 - 10 PC. 1" single hook (87502-051)
 - 5 PC. 1" double hook (87502-061)
- Heavy duty design for storage heavy duty tool
- Powder coating finishing
- Full opened door with 2 aluminum alloy handles
- 4 holes on the back of cabinet to be fixed on the wall
- Double wall door panel design, peg hole at inside wall of door

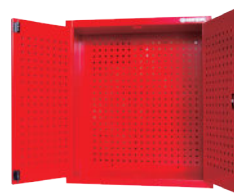

Steel thickness: (body) 1.0 mm



87502-050



87502-051



87502-061

KT NO.	Spec.	Dimension(mm) Width x Depth x Height	Kg	CUFT
87201	Overall	820 x 250 x 900	24.00	8



Tool Chest



87411-6B



87411-9B



87419-5B
(Extra deep)



87417-10B
(Extra deep)

- Powder coating
- Ball bearing slide
- Central locking system
- Hemmed edge design to improve strength and safety
- Drawer quick release and detent design

Selective colors:



(Produce with minimum quantity)



• Ball bearing slides

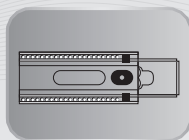

• Steel ball



• Lockable



• Plastic drawer divider for cabinet



• Bottom rubber mats to avoid slipping

KT NO.	Spec.	Dimension(mm)		kg	CUFT
		Width x Depth x Height			
87411-6B	Overall	660 x 307 x 374		25.40	3.97
	Top	646 x 290 x 60			
	3 Drawer	170 x 275 x 50			
	2 Drawer	569 x 275 x 50			
	1 Drawer	569 x 275 x 75			
87411-9B	Overall	660 x 307 x 427		30.20	4.3
	Top	646 x 290 x 60			
	6 Drawer	170 x 275 x 50			
	2 Drawer	569 x 275 x 50			
	1 Drawer	569 x 275 x 75			

KT NO.	Spec.	Dimension(mm)		kg	CUFT
		Width x Depth x Height			
87419-5B	Overall	660 x 455 x 483		40.00	8.58
	Top	646 x 420 x 70			
	2 Drawer	576 x 410 x 48.5			
	3 Drawer	576 x 410 x 75			
87417-10B	Overall	660 x 455 x 483		51.20	8.58
	Top	646 x 420 x 70			
	6 Drawer	169 x 410 x 48.5			
	1 Drawer	169 x 410 x 154			
	2 Drawer	576 x 410 x 48.5			
	1 Drawer	576 x 410 x 75			



87421-3B



87422-3B (Extra deep)

- 3 drawer chest
- Intermediate type
- Heavy gauge steel
- Drawer slides type-ball bearing
- Grooved full width drawer pulls add strength and offer to list contents of drawer
- Central locking system
- 10mm Top mat
- Powder coating finish
- 4 pins on the middle chest corners to tie in with top chest for extra security
- Overall size (mm) - 660(W) x 307(D) x 251(H) for 87421-3B
Overall size (mm) - 660(W) x 455(D) x 254(H) for 87422-3B

KT NO.	Spec.	Dimension(mm) Width x Depth x Height	Kg	CUFT
87421-3B	Overall	660 x 307 x 251	13.00	2.7
	2 Drawer	569 x 275 x 50		
	1 Drawer	569 x 275 x 75		
87422-3B	Overall	660 x 455 x 254	24.8	5
	2 Drawer	576 x 410 x 48.5		
	1 Drawer	576 x 410 x 75		

Selective colors:



(Produce with minimum quantity)

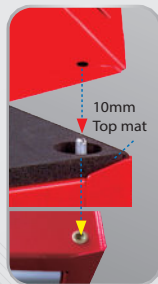

• Ball bearing slides

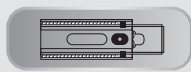

• Steel ball



- Heavy gauge steel plus flange reinforced design
- Close cover synchronously lock all of the drawers
- Powder coating
- Overall size (mm) - 535(W) x 220(D) x 287(H)

KT NO.	Spec.	Dimension(mm) Width x Depth x Height	Kg	CUFT
87401-2	2 Drawer	504 x 195 x 79	8.80	2.05
87401-3	3 Drawer	504 x 195 x 52	10.20	
87401-3H	3 Drawer	504 x 195 x 52	11.20	



87401-2



87401-3



87401-3H

Only 87401-3H:



• Internal lock system



• Ball bearing slides

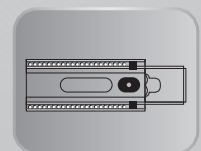

• Steel ball



Tool Box

87402

- 3 section fold up type and adjustable
- Tubular handle, curved hinge
- Shaped pressing on flat surface to reinforced steel strength

KT NO.	Spec.	Dimension(mm) Width x Depth x Height	Kg	CUFT
87402	5	470 x 220 x 260	5.60	1.22
87408	compartments	530 x 220 x 260	6.70	1.3

87A05

- 3 section fold up type and adjustable
- Tubular handle, curved hinge
- Shaped pressing on flat surface to reinforced steel strength

KT NO.	Spec.	Dimension(mm) W x D x H	Kg	CUFT
87A05	5 compartments	470 x 220 x 260	5.10	1.41
87A05-KB				
87A051		530 x 220 x 260	6.80	1.48
87A051-KB				

87A05-KB

87408



87A051

87A051-KB



87A08

- Material : PP + Metal
- Shock-resistant reinforced polypropylene shell with metal cover
- Impact resistant and sturdy bumper at corners
- 30kgs load on top and stackable design
- V groove on top for sawing or placement
- Easy to use with grip handle for carry
- Portable tote tray take tools or small parts
- Lockable allow use padlock for security
- Metal double clasp

KT NO.	Spec.	Dimension(mm) Width x Depth x Height	Kg	CUFT
87A08	2 compartments	470 x 210 x 207	2.0	0.91



87404

- Material : PP
- Multi-function box, extra space for tools and parts
- Lightweight
- Durable design for tool storage



87404

87407



87407

KT NO.	Spec.	Dimension(mm) Width x Depth x Height	Kg	CUFT
87404	2	560 x 278 x 270	2.40	1.75
87407	compartments	445 x 240 x 206	1.74	0.79



Parts Box

87137

- Parts box
- Material : PP

KT NO.	Dimension(mm) Width x Depth x Height		
	180 x 39 x 96	109	
87137	180 x 39 x 96	109	



• PP plastic storage box for spare parts

Portable Storage Box

8714101B

- Adjustable compartment is suitable for arranging different size of parts and accessories
- Transparent cover make it easy to find the parts you need
- The box is stackable design, you can combine two boxes together easily
- Durable material, easy to carry



- Adjustable compartment
- Suitable for arranging parts & accessories
- Stackable design
- Slide to lock



KT NO.	Size mm		
8714101B	376 x 290 x 67	790	1 / 16

Fabric Tool Bag

87711C

- Waterproof 600D Oxford
- Lightweight stainless bar & comfortable EVA handle
- Velcro cover for easy access & quickly take out tools
- Adjustable ambi-bag with soft padded shoulder strap

- 39 inner pockets for multiple-tools storage
- 50% less weight than metal box

KT NO.	Dimension(mm) Width x Depth x Height			
	510 x 255 x 345	3.00		
87711C	510 x 255 x 345	3.00	1 / 1	



87721B

- Heavy duty 600D Oxford
- Wide opening at top with zipper for easy access and security
- Removable shoulder strap
- Removable compartment for greater organization
- External and internal side pockets

KT NO.	Dimension(mm) Width x Depth x Height			
	360 x 200 x 260	0.95		
87721B	360 x 200 x 260	0.95	1 / 1	





Fabric Tool Bag

87722B

- Waterproof, reinforced rubber base protects tools
- 600D Oxford
- Internal and external storage pockets
- Zip fastening and rubber comfort grip handles
- Removable padded shoulder strap for comfortable carry

KT NO.	Dimension(mm)			
	Width x Depth x Height			
87722B	380 x 230 x 350	1.80	1 / 5	



87732D

- For travelling, gyms
- Shoe compartment with a waterproof material
- Multi-layered and able to carry all types of protective gear
- Durable hard bumpers on base corners
- Inner flat zippered mesh pocket on flap and main compartment separation

CONSTRUCTION :

- 2 ventilation holes on the side
- 2 big webbing handle on top and the side to be able to move and carry the bag
- 2 strap handles to lift up the bag and carry on the shoulder
- 2 mesh pockets on internal sides of the bag
- 2 small front pockets
- 2 side pockets with zippers

KT NO.	Dimension(mm)			
	Width x Depth x Height			
87732D	500 x 260 x 210	1.00	20	



87724D



- External and internal side pockets
- Removable shoulder strap
- 600D Nylon Oxford

KT NO.	Dimension(mm)			
	Width x Depth x Height			
87724D	330 x 125 x 250	0.52	20	



87733D

- Durable fabric, smooth zipper and soft padding back
- Comfortable and Long-Lasting Usage
- Adjustable Waist Belt max to 130cm
- With 3 zippered pockets
- Convenient Earphone Hole
- Glow-in-the-dark logo keep you safe in the dark

KT NO.	Dimension(mm)			
	Width x Depth x Height			
87733D	420 x 120 x 150	0.19	50	



Multi-use Backpack

87731D

- Multi-layered, easy to organize
- Extra side pocket



• External USB charge port design





• The breathable and comfortable shoulder straps foam is added inside



KT NO.	Dimension(mm) Width x Depth x Height		
87731D	310 x 150 x 440	0.6	40

87723B

- Material: 600D polyester
- Max Load: 20 kg
- Includes 14 pockets
- A water-proof and wear-resistant PVC base
- The main bag has a large capacity for easy access to tools. Multiple pockets can hold various tools within the backpack

KT NO.	Dimension(mm) Width x Depth x Height		
87723B	350 x 210 x 490	1.75	4



• The pads on the back of the product can absorb vibrations and increase breathability, making it more comfortable to carry





Modular Stacking Box

Modular Stacking Box

According to the demand of tools in different working environments, we've designed toolboxes to cope with different working situations. It is more convenient for the out-of-home technician to carry the tools, also reducing the time for the technician to go back and forth between the vehicle and the construction site.

This saves the technician's time and energy, improving the technician's work efficiency and mobility



- For better clarity you can attach labels to either the front or the sides of the case to optimize your workflow



- Fixing boxes in pallet truck



- I-Locking the 90° twist system is also extremely practical since you can open it just using one hand



- With four swivel casters of which two are braked by an integrated brake





•The sturdy and ergonomic handles on the lid and in the front can be easily carried according to your requirement

• The double-layer tool pouch can adjust the space through the buckle to facilitate the user take the tools



87405-3
456 x 372 x 262 mm



87405-2
456 x 372 x 155 mm



87405-1
456 x 372 x 115 mm



87405-9
655 x 490 x 170 mm



Tool Box Set

37 PC.



9052-001MRV

Plastic case size (mm) :
456 x 372 x 155 (0.93 cuft)

TOOLS STORAGE & TOOLS SYSTEM SETS



Pouch 1

6 PC.



Pouch 2

21 PC.



EVA foam(9-90110GPV)

10 PC.



Pouch 1

Contents



6CB21

6716-06A

6216-06A

6336-08A



6318-08A

6146-08A

Pouch 2

Contents

	1471	PH0 x 75, PH1 x 100, PH2 x 100
	1472	3 x 75, 4 x 100, 5.5 x 125, 6.5 X 150
	1120MR	H1.5, H2, H2.5, H3, H4, H5, H6, H8, H10
	20002UB	5 x 6mm, 8 x 10mm



6CB02

3611VE-08

79095-05M

EVA foam(9-90110GPV)

Contents



8.69

CUFT 1.16



6511-10

3611-10R

76223-08

76210-10



7821-50

67B3-55

9CJ1120

6AG11-20



6311-08

67A1-07

Tool Box Set

112 PC.



9052-002MRV

Plastic case size (mm) :
456 x 372 x 155 (0.93 cuft)



Pouch 1

13 PC.



Pouch 2

7 PC.



EVA foam(9-7592MPV)

92 PC.



Pouch 1

Contents

	1062	8, 9, 10, 11, 12, 13, 14, 16, 17, 18, 19, 22
	9TA281	

Pouch 2

Contents

3611-10R	6AB31-75	6211-06	6111-07
6311-08	6511-10	79095-05M	

EVA foam(9-7592MPV)

Contents



10.46 KG 1.16 CUFT

	2335MR	4, 4.5, 5, 5.5, 6, 7, 8, 9, 10, 11, 12, 13, 14
	4335MR	10, 13, 15, 16, 17, 18, 19, 20, 21, 22, 24, 27, 30, 32
	1147PR	T10H, T15H, T20H, T25H, T27H, T30H, T40H, T45H, T50H
	1120MR	H1.5, H2, H2.5, H3, H4, H5, H6, H8, H10
	20002UB	5 x 6mm, 8 x 10mm
	1032CQ	
	1005APR	
	2792	
	4791R	
	4251-10R	
	2179DF	
	7821-30	
	4773-10GS	
	2755-55G	
	2142	





Handy case

Handy Case Series

The outside of handy case can afford high load capacity, and great crash-resistance. There are four different sizes with the conception of T.C.S mod. Therefore, its design is based on the user perspective , easy to carry and store, make every user enjoying their work.

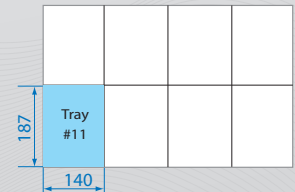
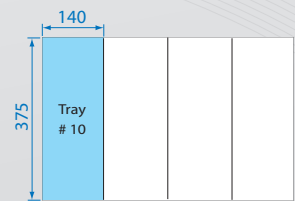
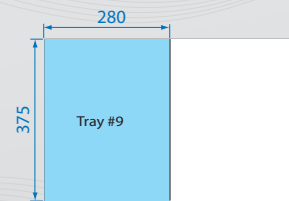
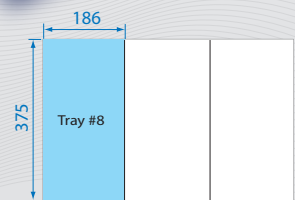
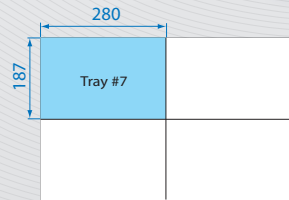
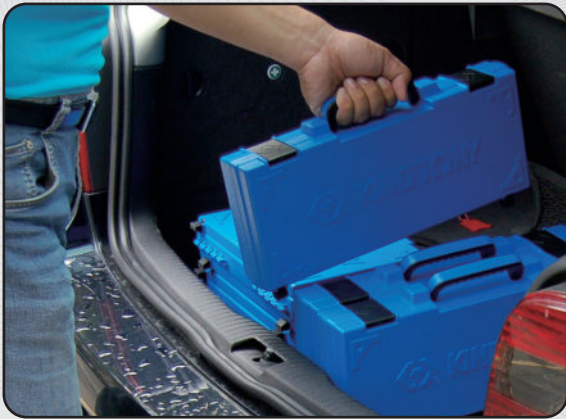

Handy Case

820011

- Made of shockproof PE-HD for heavy duty contents
- Ideal for tool storage & tool box system
- Easy to pile and store
- Anti-collision
- Case for Eva foam / tray



• Steel buckle provides security & strength



• Foam protection against collisions



• Hexagon overlap in 4 corners, easy to file up



• Extra space for thumb taking out

KT NO.	Size mm	EVA / Tray		
820011	422 x 372 x 92	#9	1417	1 / 4

82000

- Tool case made of sturdy ABS material
- Ideal for tool storage & tool box system
- Easy to pile and store
- Case for Eva foam / tray



• Plastic padding for better stable storage
• The hinge construction makes box more durable



• 180° swivel handle easy to carry



• Easy and quick to lock



• Foam protection against collisions



• Hexagon overlap in 4 corners, easy to pile up



• Extra space for thumb taking out

KT NO.	Size mm	EVA / Tray		
820001	294 x 231 x 66	# 7	641	1 / 6
820002	389 x 184 x 66	#10	651	1 / 5
820003	389 x 229 x 66	# 8	793	1 / 4
820005	199 x 171 x 50	#11	293	1 / 8

Multi-Storage Case

827011

- Heavy duty plastic blow case with foam padded internal
- High impact polystyrene with dividers make 12 spaces
- Easy to carry tools from trolley & store bolts, nuts
- Mini case (278 x 87 x 42 mm)



Blow case size (mm) :
422 x 372 x 92 (0.51 Cuft)

KT NO.	Contents		
827011	84700011B x4	2.19	1 / 4

Plastic Tray

847000

- For accessories, parts and consumables
- Easily combine the parts box sizes depending on the handy case
- Easy to carry and segment

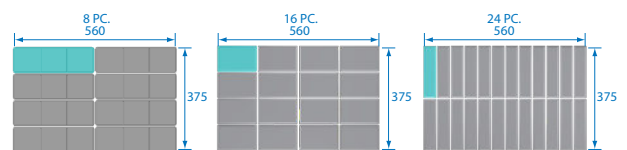

KT NO.	Size		
84700011B	283 x 93 x 43	150	8 / 72
84700002B	140 x 93 x 43	75	16 / 144
84700003B	187 x 47 x 43	50	24 / 216



Tools Control & Security Storage System

How to complete your tool trolley set and tool chest set

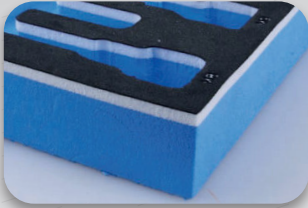

Three-colors fabrication



waterproof



Laser marking



Missing tools detected

Drawer (646x290 mm)

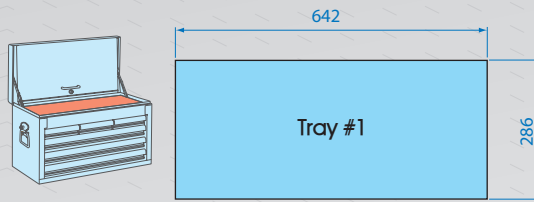

Drawer (172x275 mm)

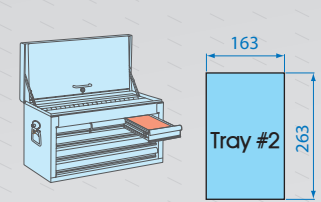

Drawer (572x275 mm)

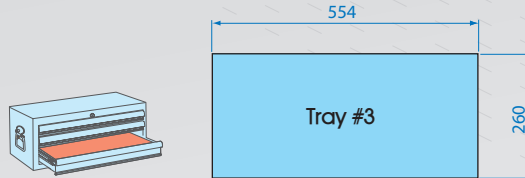

Drawer (579x380 mm)

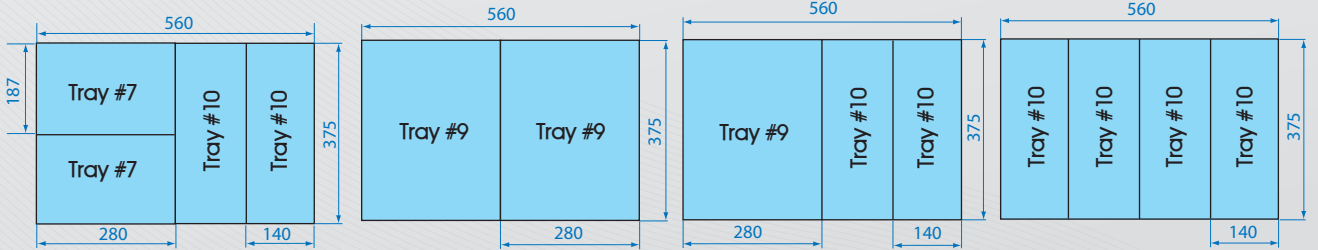
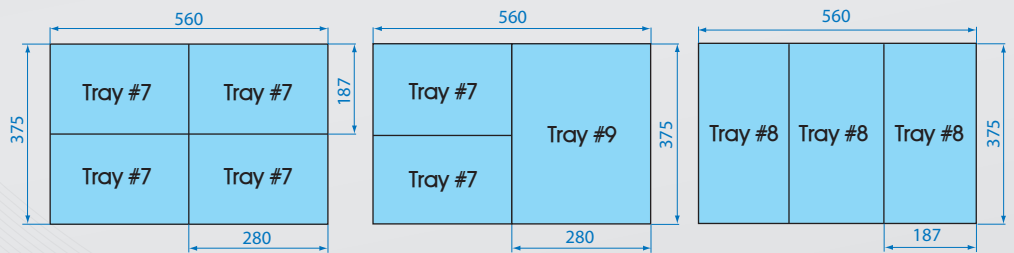
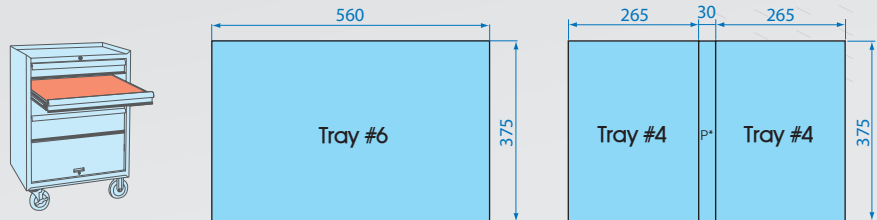

Drawer (896 x 379 mm)

▪ for 87462-7G-KB

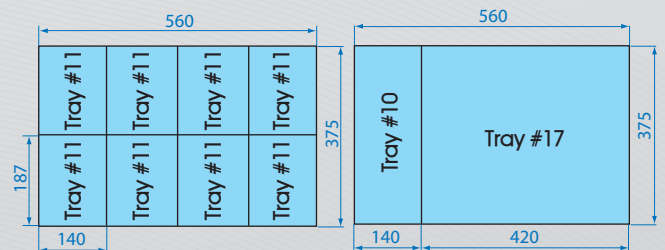
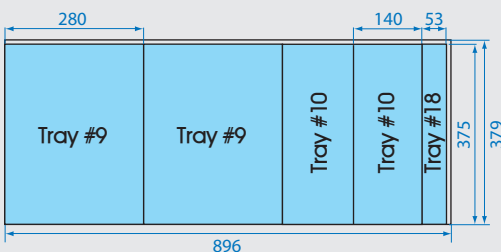
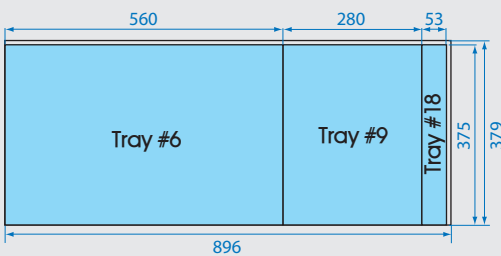

▪ **Security:**

Separate spaces for each tools to prevent them being left in dangerous areas

▪ **Benefit:**

Tools are quickly located and immediately returned after use to avoid loss

3 colors EVA foam offers convenient identification of use with sustained sizes and mark

▪ **Efficiency:**

A quick glance helps for missing tools

Durable material prevents being dirty for easy maintenance





Tool Trolley Contents

235 PC.



Contents No. 934-235MRVD

24.15 CUFT 2.62

- Special tool set for Automobile, suitable for VOLKSWAGEN-GROUP, MERCEDES-BENZ, OPEL, BMW & Japanese passenger car



9-4537MRV #9 P.80



9-2565MRV #7 P.76
9-4129PRV #7 P.76



9-4147PRV #10 P.88

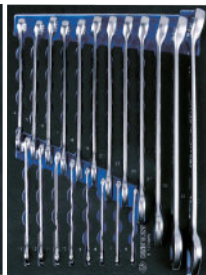

9-90135MRV #10 P.88



9-1220MRV #9 P.81



9-31124MRV #6 P.75

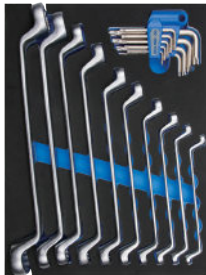

9-90119MRV #9 P.82



9-40104GPV #10 P.88
9-40113GPV #10 P.88



9-44214GPV #10 P.88



9-90118PRV #10 P.89



Tool Trolley Set

235 PC.



88.15
CUFT 14.86



934-235MRV
(87434-7B P.37)



934-235MRV-G
(87434-7B-G P.37)



934-235MRV-B
(87434-7B-B P.37)



90.29
CUFT 18.26



9634-235MRV
(87634-7B P.38)



9634-235MRV-G
(87634-7B-G P.38)



9634-235MRV-B
(87634-7B-B P.38)



Tool Trolley Contents

286 PC.



Contents No. 934-010MRVD 28.1 CUFT 2.51

- Special tool set for automobile, suitable for VOLKSWAGEN-GROUP, MERCEDES-BENZ, OPEL, BMW & Japanese passenger car



9-3544MRV #9 P.79



9-4537MRV #9 P.80



9-4147PRV #10 P.88



9-4401MPV #10 P.88



9-2565MRV #7 P.76
9-4129PRV #7 P.76



9-90119MRV #9 P.82



9-1220MRV #9 P.81

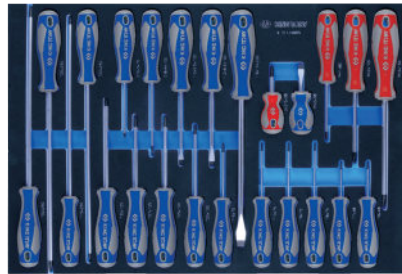

9-31124MRV #6 P.75



9-40104GPV #10 P.88



9-40113GPV #10 P.88



9-90135MRV #10 P.88



9-90118PRV #10 P.89

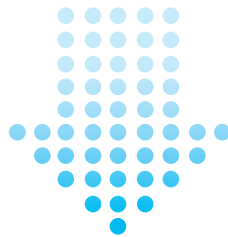

Tool Trolley Set

286 PC.



92.10
CUFT 15.03



934-010MRV
(87434-7B P.37)



934-010MRV-G
(87434-7B-G P.37)



934-010MRV-B
(87434-7B-B P.37)



94.24
CUFT 18.43



9634-010MRV
(87634-7B P.38)



9634-010MRV-G
(87634-7B-G P.38)



9634-010MRV-B
(87634-7B-B P.38)



Tool Trolley Contents

325 PC.



Contents No. 934-011MRVD

33.14 CUFT 3.75



9-3544MRV #9 P.79 | 9-4537MRV #9 P.80



9-2565MRV #7 P.76 | 9-1112MRV #9 P.82
9-4143FRV #7 P.77

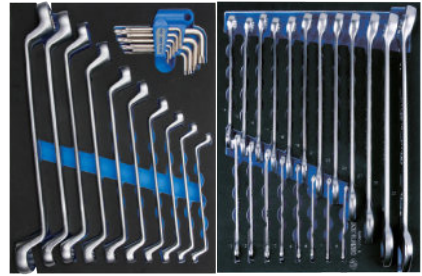

9-90119MRV #9 P.82 | 9-1220MRV #9 P.81

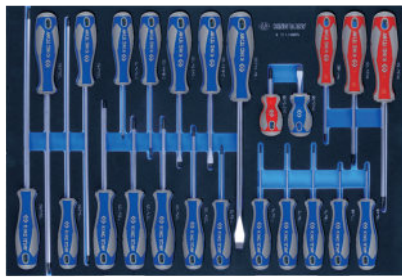

9-31124MRV #6 P.75



9-40104GPV #10 P.88 | 9-40113GPV #10 P.88
9-90135MRV #10 P.88 | 9-90118PRV #10 P.89



9-90413TQV #6 P.75

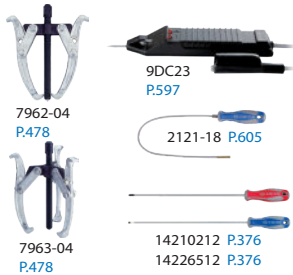

7962-04 P.478

9DC23 P.597

2121-18 P.605

7963-04 P.478

14210212 P.376
14226512 P.376

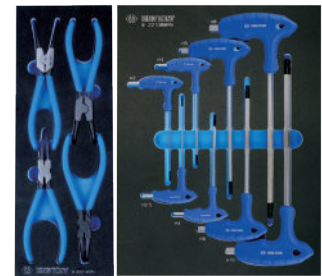

9-44214GPV #10 P.88 | 9-22108MRV #9 P.83

Tool Trolley Set

325 PC.

97.14
CUFT 15.99



934-011MRV
(87434-7B P.37)



934-011MRV-G
(87434-7B-G P.37)



934-011MRV-B
(87434-7B-B P.37)

99.28
CUFT 19.39



9634-011MRV
(87634-7B P.38)



9634-011MRV-G
(87634-7B-G P.38)



9634-011MRV-B
(87634-7B-B P.38)



Tool Trolley Contents

327 PC.



Contents No. 934-019MRVD Kg 56.68 CUFT 4.6



9-9003MRV01 #6 P.72



9-6314MRV #6 P.72



9-99430MFV #6 P.72



9-30208MRV #9 P.83



9-1220MRV #9 P.81



9-42116GPV #9 P.82



9-6414MPV #9 P.81



9-40104GPV #10 P.88



9-40113GPV #10 P.88



9-4147PRV #10 P.88



9-10112MRV #7 P.77
9-4143FRV #7 P.77



9-1044CQV #10 P.89
9-21-20-07MRV #10 P.89



Tool Trolley Set

327 PC.



Kg 120.68
CUFT 16.84



934-019MRV
(87434-7B P.37)



934-019MRV-G
(87434-7B-G P.37)



934-019MRV-B
(87434-7B-B P.37)



Kg 122.82
CUFT 20.24



9634-019MRV
(87634-7B P.38)



9634-019MRV-G
(87634-7B-G P.38)



9634-019MRV-B
(87634-7B-B P.38)



Tool Trolley Contents

525 PC.



Contents No. 935-525CRVD

68.08 CUFT 6.51



9-9003MRV01 #6 P.72



9-6314MRV #6 P.72

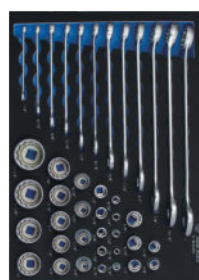

9-9040SRV #9 P.80



9-4129PRV #7 P.76

9-3612MR #7 P.127



9-4147PRV #10 P.88



9-4401MPV #10 P.88

9-4435MP #9 P.129



9-1112MRV #9 P.82



9-1220MRV #9 P.81

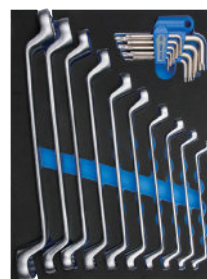

9-90119MRV #9 P.82



9-91190CRV #9 P.83



9-91124MRV #6 P.75



9-90217GRV #6 P.74

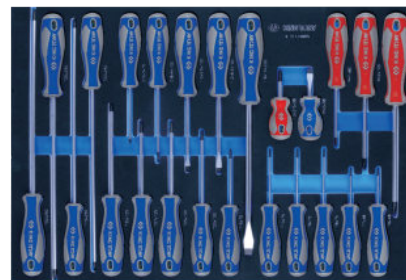

9-31124MRV #6 P.75



9-22108MRV #9 P.83



9-4143FRV #7 P.77

9-30904AY #7 P.127



9-90413TQV #6 P.75



74010 P.493

74020 P.493

74060 P.493



7861-16 P.470

7811-12 P.470

7851-16 P.471



7911-12 P.494

21-20-101 P.481

6532-14 P.370



79094-08C P.482



Tool Trolley Set

525 PC.



234.08
CUFT 38.05

935-525CRV
(87435-13B P.38)

Tool Chest Set

187 PC.



911-004CRV

47.38 CUFT 6.51



9-9077CRV #1 P.69



9-42102GPV #2 P.70

9-40122GPV #2 P.70

9-40112GPV #2 P.70



9-91131MRV #3 P.71



9-91126SRV #3 P.71



9-90145CRV #3 P.71



79093-05C P.482



7811-16 P.470



87411-6B P.48

Tool Chest Set

219 PC.



911-000CRV

48.27 CUFT 6.10



9-7069CRV #1 P.69



9-42114GPV #2 P.70

9-40102GPV #2 P.70

9-2548CRV #2 P.70



9-90129CRV #3 P.71



9-90128SR #3 P.111



9-90138CR #3 P.112



87411-6B P.48



Tool Chest Set

306 PC.



919-001CRV

66.01 CUFT 11.05



9-9003MRV01 #6 P.72

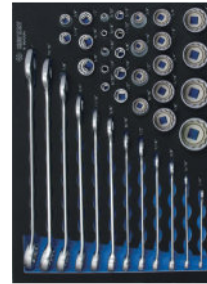

9-9040SRV #9 P.80



9-1220MRV #9 P.81



9-90217GRV #6 P.74

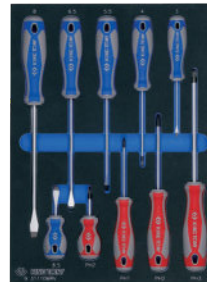

9-31110MRV #9 P.84

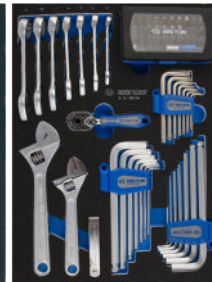

9-91190CRV #9 P.83



9-91124MRV #6 P.75



79094-08C P.482



87419-5B P.48

7911-12 P.494



Tool Set Content

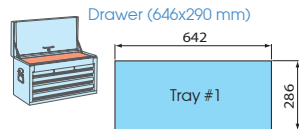

9-7069CRV

Tray category #1 (642 x 286mm)

70 PC.

Contents		7.5	1 / 2
	3330M	6, 7, 8, 9, 10, 11, 12, 13, 14, 15, 16, 17, 19, 20, 21, 22	
	3330S	3/8, 7/16, 1/2, 9/16, 5/8, 11/16, 3/4, 13/16	
	4330MR	10, 11, 12, 13, 14, 15, 16, 17, 18, 19, 20, 21, 22, 23, 24, 27, 30, 32	
	4330SR	3/8, 7/16, 1/2, 9/16, 5/8, 11/16, 3/4, 13/16, 7/8, 15/16, 1	
	463516RC		463521RC
	4791R		3779-08G
	4779-10GR		3452-08F
	4452-15FR		3812
	3571-08		4572-10
	4813		3221-03
	3221-06		4251-05R
	4251-10R		7911-12



9-9077CRV

Tray category #1 (642 x 286mm)

77 PC.

Contents		7.95	1 / 2
	2330M	4, 5, 6, 7, 8, 9, 10	
	2330S	3/16, 7/32, 1/4, 9/32, 5/16, 11/32, 3/8	
	3330M	10, 11, 12, 13, 14, 15, 17, 19	
	3330S	3/8, 7/16, 1/2, 9/16, 5/8, 11/16, 3/4, 13/16	
	4330MR	10, 11, 12, 13, 14, 15, 16, 17, 18, 19, 20, 21, 22, 23, 24, 27, 30, 32	
	4330SR	3/8, 7/16, 1/2, 9/16, 5/8, 11/16, 3/4, 13/16, 7/8, 15/16, 1, 1-1/16, 1-1/8, 1-3/16, 1-1/4	
	463021RC		2792
	3792		3792
	4791R		2779-55G
	3779-08G		3814
	4779-10GR		2221-04
	3221-06		4251-10R
	3452-08F		4452-15FR
	4572-12		





Tool Set Content

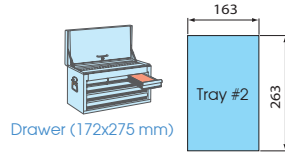

9-2548CRV Tray category #2 (263 x 163mm)

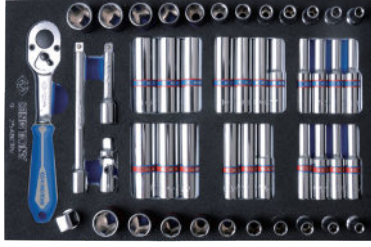

48 PC.

Contents

1.28 kg 1 / 10

	2235M	4, 5, 5.5, 6, 7, 8, 9, 10, 11, 12, 13
	2235S	5/32, 3/16, 7/32, 1/4, 9/32, 5/16, 11/32, 3/8, 7/16, 1/2
	2335M	4, 4.5, 5, 5.5, 6, 7, 8, 9, 10, 11, 12, 13
	2335S	5/32, 3/16, 7/32, 1/4, 9/32, 5/16, 11/32, 3/8, 7/16, 1/2
	2792	
	2813	
	2779-55G	
	2221-02	
	2221-04	

9-40102GPV Tray category #2 (263 x 163mm)



2 PC.

Contents

1.00 kg 1 / 10

	6011-10R		6511-10
--	----------	--	---------

9-40112GPV Tray category #2 (263 x 163mm)



2 PC.

Contents

0.69 kg 1 / 10

	6231-08		6311-08
--	---------	--	---------

9-40122GPV Tray category #2 (263 x 163mm)



2 PC.

Contents

0.95 kg 1 / 10

	6111-08		6011-10R
--	---------	--	----------

9-42102GPV Tray category #2 (263 x 163mm)

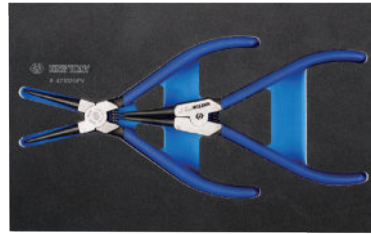

2 PC.

Contents

0.32 kg 1 / 10

	68HS-07		68SS-07
--	---------	--	---------

9-42114GPV Tray category #2 (263 x 163mm)



4 PC.

Contents

0.60 kg 1 / 10

	68HS-07		68SS-07
	68HB-07		68SB-07

Tool Set Content

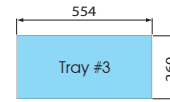
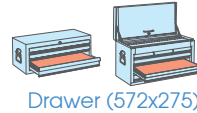

9-91126SRV

Tray category #3 (554 x 260mm)

Contents		3.28 kg	1 / 3
5060	1/4, 5/16, 3/8, 7/16, 1/2, 9/16, 5/8, 11/16, 3/4, 13/16, 7/8, 15/16, 1		
5930	5/16 x 3/8, 3/8 x 7/16, 1/2 x 9/16, 9/16 x 5/8		
1130SR	3/32, 1/8, 5/32, 3/16, 1/4, 5/16, 3/8		
3611R	6, 12		



26 PC.

9-91131MRV

Tray category #3 (554 x 260mm)

Contents		2.98 kg	1 / 4
1930	8x10, 10x12, 11x13, 14x17		
1060	6, 7, 8, 9, 10, 11, 12, 13, 14, 15, 16, 17, 18, 19, 20, 21, 22, 24		
1125MR	H1.5, H2.5, H2, H3, H4, H5, H6, H8, H10		



31 PC.

9-90145CRV

Tray category #3 (554 x 260mm)

Contents		4.04 kg	1 / 3
1060	27, 30, 32		
5060	1-1/16, 1-1/8, 1-1/4		
1481	PH1x75, PH2x100, PH3x150		
1482	5.5x75, 6.5x100, 8x150		
1025S	3.0, 4.0, 5.0, 6.0		
1025P	PH1, PH2 x 2, PH3		
1025Z	PZ1, PZ2 x 2, PZ3		
1025T	T10, T15, T20, T25, T27, T30, T40		
1025H	H3, H4, H5, H6		
1025U	T10H, T15H, T20H, T25H, T27H, T30H, T40H		
7702-25	753-63	2141	



45 PC.

9-90129CRV

Tray category #3 (554 x 260mm)

Contents		2.5 kg	1 / 4
1421	PH0 x 60, PH1 x 80, PH2 x 38, PH2 x 100, PH3 x 150		
1422	3 x 75, 6.5 x 38, 6.5 x 100, 6.5 x 150, 8 x 175		
1130SR	3/32, 1/8, 5/32, 3/16, 1/4, 5/16, 3/8		
1120MR	H1.5, H2, H2.5, H3, H4, H5, H6, H8, H10		
6111-07	6231-07		
6311-06			



29 PC.



Tool Set Content

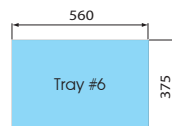
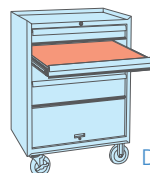

Drawer (579 x 380 mm)



9-6314MRV

Tray category #6 (560 x 375mm)

Contents

9.96 kg 1/2

		6335M	33, 34, 35, 36, 38, 41, 46, 50
		6572-20	6779-20F
		6251-04	6251-08
		6251-16	6814



14 PC.

9-9003MRV01

Tray category #6 (560 x 375mm)

Contents

7.30 kg 1/3

		2235M	4, 4.5, 5, 5.5, 6, 7, 8, 9, 10, 11, 12, 13
		2335M	4, 4.5, 5, 5.5, 6, 7, 8, 9, 10, 11, 12, 13
		3023	T10, T15, T20, T25, T27, T30, T40, T45, T50
		3025	H3, H4, H5, H6, H8, H10, H12
		3235M	10, 12, 13, 14, 15, 16, 17, 18, 19, 21
		3330M	8, 10, 11, 12, 13, 14, 15, 16, 17, 18, 19, 20, 21, 22
		4330MR	10, 12, 13, 14, 15, 16, 17, 18, 19, 20, 21, 22, 23, 24, 27, 28, 30, 32
		7702-50	7703-50
		2792	3792
		4791R	
		363516	363521
		36A014	



103 PC.

Contents

		2813			3812		4813
		2221-02			3221-03		4251-05R
		2221-04			3221-10		4251-10R
		2771-55G			3771-08G		
		4771-10GR			4462-18F		

9-99430MFV

9-99430MFV01

Tray category #6 (560 x 375mm)



30 PC.

9-99430MFV

Contents

12.38 kg 1/2

		8435M	27, 30, 32, 33, 36
		6575M	E24, E26, E28, E30, E32
		3375M	E4, E5, E6, E7, E8, E11
		4375M	E10, E12, E14, E16, E18, E20, E22
		4025	H14, H17, H19
		8866P	7823-20
		320560	9DC22



31 PC.

9-99430MFV01

Contents

12.38 kg 1/2

		8435M	27, 30, 32, 33, 36
		6575M	E24, E26, E28, E30, E32
		3375M	E4, E5, E6, E7, E8, E11
		4375M	E10, E12, E14, E16, E18, E20, E22
		4025	H14, H17, H19
		4866P	8866P
		7823-20	
		320560	9DC22

Tool Set Content

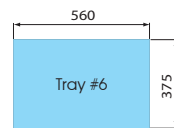
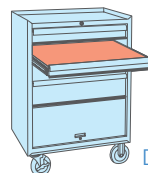

Drawer (579 x 380 mm)



9-44803AMPV

9-44803AMPV01

Tray category #6 (560 x 375mm)



9-44803AMPV



9-44803AMPV01

41 PC.

KT NO.	Contents		kg 9.50	1/2
9-44803AMPV		<ul style="list-style-type: none"> 4945M 17, 19, 21 4435M 10, 11, 12, 13, 14, 15, 16, 17, 18, 19, 21, 22, 24 	<ul style="list-style-type: none"> 79900-10 34423-1A 	
9-44803AMPV01		<ul style="list-style-type: none"> 4535M 10, 11, 12, 13, 14, 15, 16, 17, 18, 19, 21, 22, 24, 27, 30, 32 	<ul style="list-style-type: none"> 4797P 4260-03P 4260-05P SY-211M x2 33411-71 	

9-44805AMPV

Tray category #6 (560 x 375mm)

Contents		kg 9.76	1/2
	4945M 17, 19, 21		
	4435M 10, 11, 12, 13, 14, 15, 16, 17, 18, 19, 21, 22, 24		
	4535M 10, 11, 12, 13, 14, 15, 16, 17, 18, 19, 21, 22, 24, 27, 30, 32		



41 PC.

9-94437MRV

Tray category #6 (560 x 375mm)

Contents		kg 4.61	1/2
	1060 8, 9, 10, 11, 12, 13, 14, 15, 16, 17, 18, 19, 20, 21, 22, 23, 24		
	3731M 8, 10, 11, 12, 13, 14, 15		
	4435M 17, 19, 21		
	1836P PH2, PH3		
	1836S 9, 11		
	1880P PH2, PH3		
	1880S 8, 10		



37 PC.





Tool Set Content

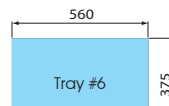
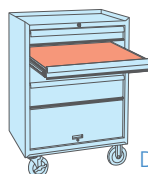

Drawer (579 x 380 mm)



9-90217GRV

Tray category #6 (560 x 375mm)

Contents

3.89 1 / 6

764	3,4,5,6		
76105-06		76717-05	
7811-16		6011-10R	
6111-08	6231-07	6311-08	
6314-05	68HB-07	68HS-07	
68SB-07	68SS-07	6511-10C	



17 PC.

9-91122MRV

Tray category #6 (560 x 375mm)

Contents

3.18 1 / 5

1060	8, 9, 10, 11, 12, 13, 14, 15, 16, 17, 19, 21, 22, 24		
115HM	H6, H7, H8, H9, H10, H11, H12, H13		



22 PC.

9-22124MRV50

Tray category #6 (560 x 375mm)

Contents

2.18 1 / 5

115HM	H7, H8, H10, H11, H12, H13		
ST20109MR		ST20419PR	



24 PC.

9-31920MRV

Tray category #6 (560 x 375mm)

Contents

2.01 1 / 2

1421	PH0 x 60, PH2 x 38, PH2 x 300		
1422	3 x 75, 6.5 x 38, 6.5 x 300		
1427	T8H x 75, T10H x 75, T15H x 75, T20H x 100, T25H x 100, T27H x 100, T30H x 125,		
1461	PH2 x 100, PH3 x 150		
1462	6.5 x 100, 8 x 150		
43280212		48280180	
2121-18			



20 PC.



Tool Set Content

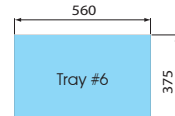
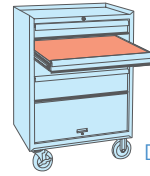

Drawer (579 x 380 mm)



9-31124MRV

Tray category #6 (560 x 375mm)

Contents		kg 2.41	1 / 5
⊕	1421	PH2x38, PH1x80, PH2x100, PH3x150	
⊖	1422	3x75, 4x100, 5.5x100, 6.5x100, 10x200, 6.5x38	
⊛	1423	T6x48, T7x48, T8x75, T9x75, T10x75, T15x75, T15x250, T20x100, T20x250, T25x100, T25x250, T27x100, T30x125, T30x250	

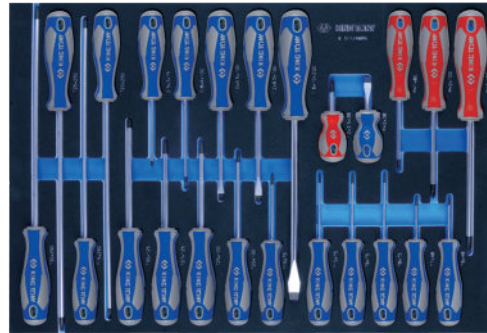

24 PC.

9-91124MRV

Tray category #6 (560 x 375mm)

Contents		kg 4.12	1 / 5
	3731	10, 12, 13, 14, 17, 18, 19	
⊕	1421	PH2 x 300	
⊖	1422	5 x 300	
	74030		6615-11
	3611-10R 3611-12R		9TK118
	79063-12		11409SQ05



24 PC.



9-90413TQV

Tray category #6 (560 x 375mm)

Contents		kg 2.49	1 / 5
⊙	115HM	8, 10, 13	
	9CZ101		115345R
	48280180		43280212
	43240115Y		75102-08G
	75202-08G		75302-08G
	75402-08G		75502-08G



13 PC.

9-91217MRV

Tray category #6 (560 x 375mm)

Contents		kg 6.11	1 / 2
⊕	1421	PH1 x 80, PH2 x 100	
⊖	1422	3 x 75, 4 x 100, 5.5 x 125, 6.5 x 150, 8 x 175	
⊛	1423	T15 x 75, T20 x 100, T25 x 100, T27 x 100, T30 x 125	
	48280180		9CF220
	7823-10 7823-20		7821-30



17 PC.



Tool Set Content

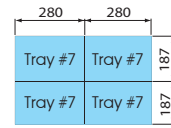
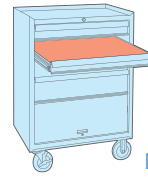

Drawer (579 x 380 mm)



9-2331SRV

Tray category #7 (280 x 187mm)

Contents

0.97 kg 1 / 10

- 2335S 5/32, 3/16, 7/32, 1/4, 9/32, 5/16, 11/32, 3/8, 7/16, 15/32, 1/2, 9/16
- 2235S 5/32, 3/16, 7/32, 1/4, 9/32, 5/16, 11/32, 3/8, 7/16, 1/2, 9/16
- 2771-55G 2571-45 2142
- 2221-02
- 2221-04 2792 2178DF
- 2221-06

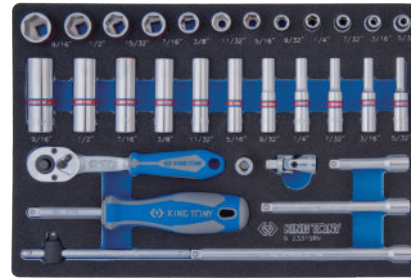

31 PC.

9-2534MRV

Tray category #7 (280 x 187mm)

Contents

1.11 kg 1 / 10

- 2335M 4, 4.5, 5, 5.5, 6, 7, 8, 9, 10, 11, 12, 13, 14
- 2235M 4, 4.5, 5, 5.5, 6, 7, 8, 9, 10, 11, 12, 13, 14
- 2771-55G 2571-45
- 2792 2178DF 2142
- 2221-02, 2221-04, 2221-06

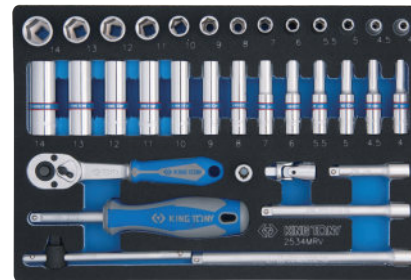

34 PC.

9-2565MRV

Tray category #7 (280 x 187mm)

Contents

1.38 kg 1 / 10

- 2335M 4, 4.5, 5, 5.5, 6, 7, 8, 9, 10, 11, 12, 13, 14
- 2235M 4, 4.5, 5, 5.5, 6, 7, 8, 9, 10, 11, 12, 13, 14
- 2375M E4, E5, E6, E7, E8
- 2013X T8, T9, T10, T15, T20, T25, T27, T30, T40
- 2015X H3, H4, H5, H6, H8
- 2018X PZ1, PZ2
- 2011X PH1, PH2
- 2012X 3.5, 5.5, 8
- 1025T T6, T7
- 1025M M4, M5, M6, M8, M10



65 PC.

Contents

- 2792 2813 276A-04G
- 2221-02, 2221-04, 2221-06

9-4138PRV

Tray category #7 (280 x 187mm)

Contents

1.85 kg 1 / 10

- 4033 T20, T25, T27, T30, T40, T45, T50, T55, T60
- 4035 H4, H5, H6, H7, H8, H10, H12, H14, H17



18 PC.

9-4129PRV

Tray category #7 (280 x 187mm)

Contents

2.07 kg 1 / 10

- 4025 H3, H4, H5, H6, H7, H8, H10, H12, H14, H17, H19
- 4026 M5, M6, M8, M10, M12, M14
- 402B M16, M18



19 PC.

Tool Set Content

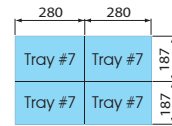
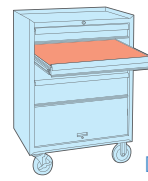

Drawer (579 x 380 mm)



9-7128PRV

Tray category #7 (280 x 187mm)

Contents

1.30 kg 1 / 10

	3023	T15, T20, T25, T27, T30, T40, T45, T50
	3025	H3, H4, H5, H6, H7, H8, H10, H12
	3375	E8, E10, E12, E14, E16, E18
	4375	E10, E12, E14, E16, E18, E20



28 PC.

9-4429MPV

Tray category #7 (280 x 187mm)

Contents

2.75 kg 1 / 4

	4535M	10, 11, 12, 13, 14, 15, 16, 17, 18, 19, 21, 22, 24, 27, 30, 32, 33, 34, 36
--	-------	--



19 PC.

9-10112MRV

Tray category #7 (280 x 187mm)

Contents

1.13 kg 1 / 10

	3731	10, 11, 12, 13, 14, 15, 16, 17, 19
	373202R	
	373203R	
	373204R	

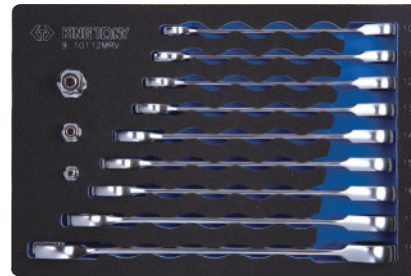

12 PC.

9-4143FRV

Tray category #7 (280 x 187mm)

Contents

1.63 kg 1 / 8

	1636H	H5, H6, H7, H8, H10, H12
	1636M	M6, M8, M10, M12
	1636T	T30, T40, T45, T50, T55, T60
	1832H	H3, H4, H5, H6, H7, H8, H10, H12
	1832T	T15, T20, T25, T27, T30, T40, T45, T50
	1836P	PH2, PH3
	1836S	9 x 1.6, 11 x 2
	1880P	PH2, PH3

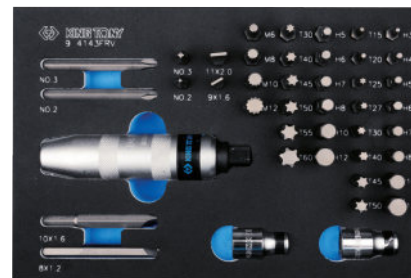

43 PC.

Contents

	1880S	8 x 1.2, 10 x 1.6
	414810M, 414810S	4112

9-25VE01MRV

Tray category #7 (280 x 187mm)

Contents

1.30 kg 1 / 10

	2335VE	5, 6, 7, 8, 9, 10, 11, 12, 13, 14,
	2035VE	H3, H4, H5, H6
	2221VE	4, 6
	2771VE-55	2178VE-05



18 PC.



Tool Set Content

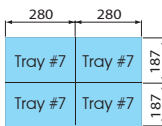
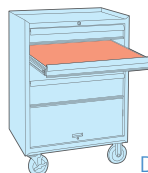

Drawer (579 x 380 mm)



9-30904AYV

Tray category #7 (280 x 187mm)

Contents

kg 0.45 / 1 / 10

- 43250115Y
- 43260115Y
- 43270115Y
- 43290115Y



4 PC.

Tool Set Content

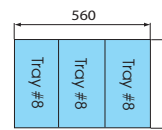
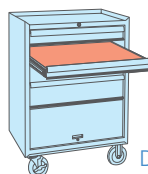

Drawer (579 x 380 mm)



9-35VE01MRV

Tray category #8 (375 x 187mm)

Contents

kg 2.16 / 1 / 6

- 3335VE 10, 11, 12, 13, 14, 17, 19
- 3025VE H5, H6, H8
- 3221VE 6, 10,
- 3771VE-08 3178VE-08



14 PC.

9-45VE01MRV

Tray category #8 (375 x 187mm)

Contents

kg 3.22 / 1 / 6

- 4335VE 8, 10, 12, 13, 14, 17, 19, 21, 22, 24
- 4025VE H8, H10
- 4251VE 5, 10
- 4771VE-10 4178VE-08



16 PC.

9-2550MRV

Tray category #8 (375 x 187mm)

Contents

kg 1.37 / 1 / 15

- 2335M 4, 4.5, 5, 5.5, 6, 7, 8, 9, 10, 11, 12, 13, 14
- 2375M E4, E5, E6, E7, E8
- 2031 PH1, PH2, PH3, PH4
- 2032 4, 5.5, 6.5, 8, 10
- 2033 T8, T9, T10, T15, T20, T25, T27, T30, T40
- 2035 H3, H4, H5, H6, H7, H8, H10



50 PC.

Contents

- 2771-55G 2178DF
- 2792 2571-45
- 2293-04 2221-02
- 2293-06



Tool Set Content

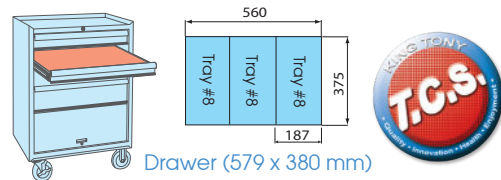

Drawer (579 x 380 mm)

9-30909AYV Tray category #8 (375 x 187mm)

- Use for scribing, alignment, installing and removing O rings, seals, cotter pins and washers
- Use for removing old gaskets more easily and quickly

Contents		Kg 0.89	1 / 12	
	43250115Y		43350175Y	
	43260115Y		43360175Y	
	43270115Y		43370175Y	
	43290115Y		43390175Y	
	43240115Y			

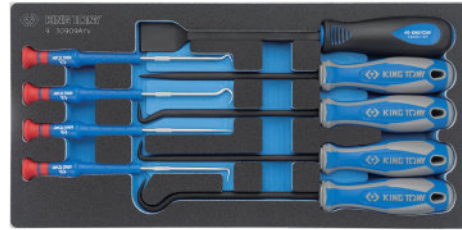

9 PC.

Tray category #8 (375 x 187mm)

Tool Set Content

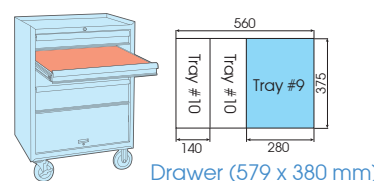

Drawer (579 x 380 mm)

9-3544MRV Tray category #9 (375 x 280mm)

Contents		Kg 3.19	1 / 5	
	3335M	10, 11, 12, 13, 14, 15, 16, 17, 18, 19, 20, 21, 22		
	3375M	E7, E8, E10, E11, E12		
	3230M	8, 10, 11, 12, 13, 14, 16, 17, 19		
	3750M	10, 11, 12, 13, 14, 15, 16, 17, 18, 19		
	3812 / 3814	3221-03 / 3221-06 / 3221-10		3779-08G



44 PC.

9-4221MRV Tray category #9 (375 x 280mm)

Contents		Kg 3.97	1 / 5	
	4230	8, 9, 10, 11, 12, 13, 14, 15, 16, 17, 18, 19, 21, 22, 24, 27, 30, 32, 33, 34, 36		



21 PC.

9-4526MRV05 Tray category #9 (375 x 280mm)

Contents		Kg 5.05	1 / 4	
	4335MR	8, 10, 11, 12, 13, 14, 15, 16, 17, 18, 19, 21, 22, 23, 24, 27, 30, 32		
	4779-10FR		4572-12	
	4452-15FR		4791R	
			4251-05R	4251-10R



24 PC.



Tool Set Content

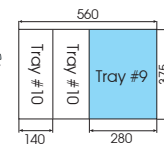
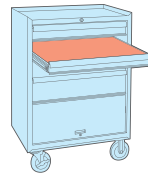

Drawer (579 x 380 mm)

9-4527MRV02

Tray category #9 (375 x 280mm)

Contents

4.72 1 / 5

		4335MR	8, 9, 10, 11, 12, 13, 14, 15, 16, 17, 18, 19, 21, 22, 23, 24, 27, 29, 30, 32
		4771-10GR	4791R
		4572-12	4251-05R 4251-10R
		4452-15FR	4581-10



27
PC.

9-4537MRV

Tray category #9 (375 x 280mm)

Contents

4.39 1 / 5

		4335MR	8, 10, 11, 12, 13, 14, 15, 16, 17, 18, 19, 20, 21, 22, 23, 24, 26, 27, 28, 30, 32
		4375M	E10, E12, E14, E16, E18, E20, E22, E24
		4779-10GR	4293-02
		4251-05R 4251-10R	463516RC 463521RC
		4791R	463014RC



37
PC.

9-9040SRV

Tray category #9 (375 x 280mm)

Contents

3.02 1 / 5

		2335S	5/32, 3/16, 7/32, 1/4, 9/32, 5/16, 11/32, 3/8, 7/16, 1/2
		3330S	3/8, 7/16, 1/2, 9/16, 5/8
		4330SR	3/8, 7/16, 1/2, 9/16, 5/8, 11/16, 3/4, 13/16, 7/8, 15/16, 1, 1-1/8, 1-1/4,
		5060	1/4, 5/16, 3/8, 7/16, 1/2, 9/16, 5/8, 11/16, 3/4, 7/8, 15/16, 1

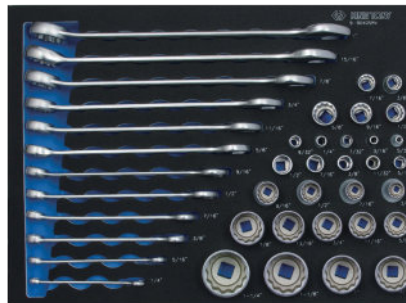

40
PC.

9-7560MRV01

Tray category #9 (375 x 280mm)

Contents

6.24 1 / 2

		2335M	4, 5, 5.5, 6, 7, 8, 9, 10, 11, 12, 13, 14
		4335MR	10, 11, 13, 14, 15, 16, 17, 18, 19, 20, 21, 22, 24, 27, 30, 32
		1025S	3, 4.5, 5, 6.5, 8
		1025P	PH0, PH1, PH2, PH3
		1025U	T10H, T15H, T20H, T25H, T27H, T30H, T40H
		1025Z	PZ1, PZ2, PZ3
		276A-04G	4771-10GR
		4452-15FR	4572-12 2745
		213312DF	2792 4791R
		2223-02 2223-04	4251-05R 4251-10R 2813



60
PC.



Tool Set Content

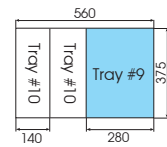
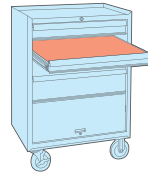

Drawer (579 x 380 mm)

Tray category #9 (375 x 280mm)

9-4419MPV

Contents

5.6 kg 1 / 2

	4435M	10, 11, 12, 13, 14, 15, 16, 17, 18, 19, 21, 22, 24, 27, 30, 32, 33, 34, 36
--	-------	--



19 PC.

9-6414MPV

Contents

10.08 kg 1 / 2

	6435M	19, 21, 22, 24, 26, 27, 29, 30, 32, 33, 35, 36, 38, 41
--	-------	--



14 PC.

Tray category #9 (375 x 280mm)

9-1220MRV

Contents

3.49 kg 1 / 4

	1060	6, 7, 8, 9, 10, 11, 12, 13, 14, 15, 16, 17, 18, 19, 21, 22, 24, 27, 30, 32
--	------	--

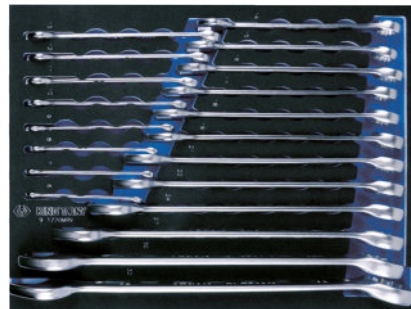

20 PC.

Tray category #9 (375 x 280mm)

9-12D20MRV

Contents

3.45 kg 1 / 4

	1062	6, 7, 8, 9, 10, 11, 12, 13, 14, 15, 16, 17, 18, 19, 21, 22, 24, 27, 30, 32
--	------	--



20 PC.

Tray category #9 (375 x 280mm)



Tool Set Content

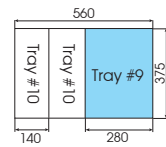
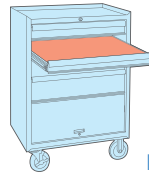

Drawer (579 x 380 mm)

Tray category #9 (375 x 280mm)

9-12A1MRV

Contents

1.75 kg 1 / 10

1061 8, 10, 12, 13, 14, 16, 17, 18, 19, 22, 24



11 PC.

9-1112MRV

Tray category #9 (375 x 280mm)

Contents

2.34 kg 1 / 4

1900 6x7, 8x9, 10x11, 12x13, 14x15, 16x17, 18x19, 20x22, 21x23, 24x27, 25x28, 30x32



12 PC.

9-90119MRV

Tray category #9 (375 x 280mm)

Contents

3.04 kg 1 / 4

1970 6x7, 8x9, 10x11, 12x13, 14x15, 16x17, 18x19, 20x22, 24x27, 30x32
1143 T10, T15, T20, T25, T27, T30, T40, T45, T50



19 PC.

9-42116GPV

Tray category #9 (375 x 280mm)

Contents

1.54 kg 1 / 5

68SB-07 68HS-07 68SS-07
68HB-07 68HS-10 68SS-10



6 PC.

Tool Set Content

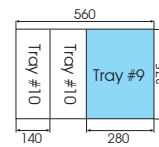
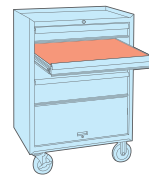

Drawer (579 x 380 mm)



9-91190CRV

Tray category #9 (375 x 280mm)

Contents

2.22 kg 1 / 10

⊖	1025S	3.0, 4.0, 5.0, 6.0
⊕	1025P	PH1, PH2 x 2, PH3
⊗	1025Z	PZ1, PZ2 x 2, PZ3
⊛	1025T	T10, T15, T20, T25, T27, T30, T40
⊙	1025H	H3, H4, H5, H6
⊚	1025U	T10H, T15H, T20H, T25H, T27H, T30H, T40H
⊠	1025R	RB2
■	7702-25	753-63
⊗	10D0	10,12,13,14,17,18,19
⊙	1130MR	H2.5, H3, H4, H5, H6, H8, H10



90 PC.

Contents

⊙	1130SR	3/32, 1/8, 5/32, 3/16, 1/4, 5/16, 3/8
⊛	1147R	T10H, T15H, T20H, T25H, T27H, T30H, T40H
⊗	3611-06R	77328-26
	3611-08R	
⊙	276A-04G	

9-22108MRV

Tray category #9 (375 x 280mm)

Contents

0.89 kg 1 / 5

⊙	1160MR	H2, H2.5, H3, H4, H5, H6, H8, H10
---	--------	-----------------------------------



8 PC.

9-22308TRV

Tray category #9 (375 x 280mm)

Contents

0.71 kg 1 / 10

⊛	1163TR	T10, T15, T20, T25, T30, T40, T45, T50
---	--------	--

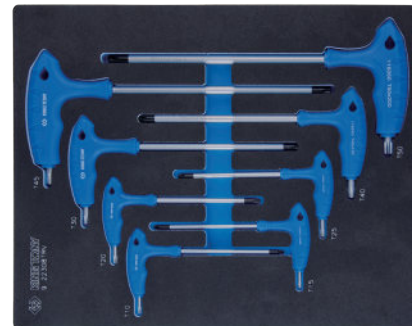

8 PC.

9-30208MRV

Tray category #9 (375 x 280mm)

Contents

1.41 kg 1 / 5

⊕	1461	PH1 x 75, PH2 x 100, PH3 x 150
⊖	1462	5.5 x 100, 6.5 x 100, 6.5 x 150, 8 x 150, 8 x 175



8 PC.



Tool Set Content

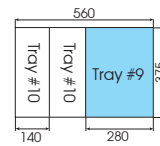
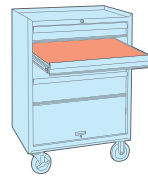

Drawer (579 x 380 mm)



9-31110MRV

Tray category #9 (375 x 280mm)

Contents

2.46 kg 1 / 5

	1421	PH1 x 80, PH2 x100, PH3 x 150, PH2 x 38
	1422	3 x 75, 4 x 100, 5.5 x 125, 6.5 x 38, 6.5 x 150, 8 x 175

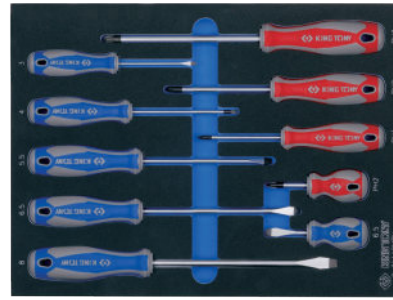

10 PC.

9-55VE01MRV

Tray category #9 (375 x 280mm)

Contents

2.34 kg 1 / 5

	2335VE	5, 6, 7, 8, 9, 10, 11, 12, 13, 14,
	2035VE	H3, H4, H5, H6
	2221VE	4, 6
	3335VE	10, 11, 12, 13, 14, 15, 16, 17, 18, 19
	3235VE	8, 10, 12, 14
	3025VE	H8, H10
	3221VE	6, 10
	2771VE-55	2178VE-05
	3771VE-08	3178VE-08



38 PC.

Tray category #9 (375 x 280mm)

9-12FVE15MRV

Tray category #9 (375 x 280mm)

Contents

1.96 kg 1 / 10

	10F0	7, 8, 9, 10, 11, 12, 13, 14, 16, 17, 18, 19, 21, 22, 24
--	------	---



15 PC.

9-12FVG15MRV

Tray category #9 (375 x 280mm)

Contents

2.86 kg 1 / 5

	10G0	7, 8, 9, 10, 11, 12, 13, 14, 16, 17, 18, 19, 21, 22, 24
--	------	---



15 PC.

Tool Set Content

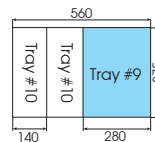
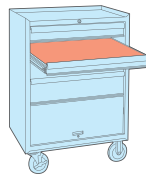

Drawer (579 x 380 mm)



9-30612MRV

Tray category #9 (375 x 280mm)



12 PC.

Contents		kg 1.30	1 / 10
1471	PH0 x 75, PH1 x 100, PH2 x 100, PH3 x 150		
1472	3 x 75, 4 x 100, 3.5 x 100, 5.5 x 125, 6.5 x 150, 8 x 175		
1474	1 x 125, 2 x 150		

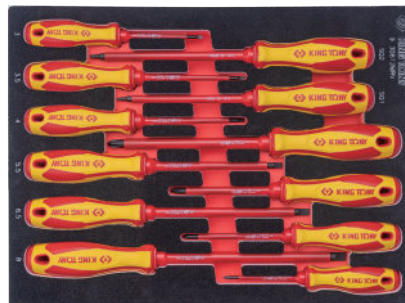

9-40606GPV

Tray category #9 (375 x 280mm)



6 PC.

Contents		kg 1.88	1 / 10
6216-06A	6116-07A		
6318-08A	6336-08A		
6716-06A	6146-08A		

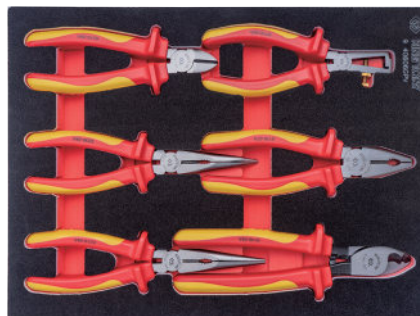



Tool Set Content

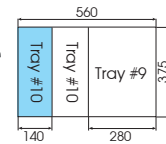
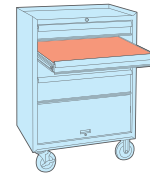

Drawer (579 x 380 mm)

9-2544SRV

9-2044SRV

Tray category #10 (375 x 140mm)



9-2544SRV



9-2044SRV

44
PC.

KT NO.

Contents

0.92 1 / 6

9-2544SRV	2335S	5/32, 3/16, 7/32, 1/4, 9/32, 5/16, 11/32, 3/8, 7/16, 15/32, 1/2	2235S 5/32, 3/16, 7/32, 1/4, 9/32, 5/16, 11/32, 3/8, 7/16, 1/2 1025S 3, 4.5, 5, 6.5, 8 1025P PH0, PH1, PH2, PH3 5025H H3/64, H1/16, H5/64, H3/32, H7/64, H1/8, H9/64, H5/32	2752-06G 2178DF 2792 2223-02 2223-04 2142
9-2044SRV	2330S	5/32, 3/16, 7/32, 1/4, 9/32, 5/16, 11/32, 3/8, 7/16, 15/32, 1/2		

9-2548MRV

9-2048MRV

Tray category #10 (375 x 140mm)



9-2548MRV

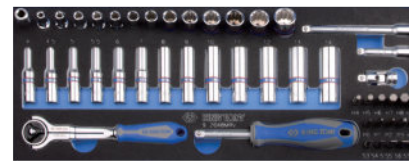

9-2048MRV

48
PC.

KT NO.

Contents

1.09 1 / 6

9-2548MRV	2335M	4, 4.5, 5, 5.5, 6, 7, 8, 9, 10, 11, 12, 13, 14	2235M 4, 4.5, 5, 5.5, 6, 7, 8, 9, 10, 11, 12, 13, 14 1025S 3, 4.5, 5, 6.5, 8 1025P PH0, PH1, PH2, PH3 1025H H3, H4, H5, H6, H7, H8, H10	2752-06G 2178DF 2792 2223-02 2223-04 2142
9-2048MRV	2330M	4, 4.5, 5, 5.5, 6, 7, 8, 9, 10, 11, 12, 13, 14		

Tool Set Content

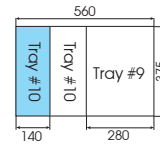
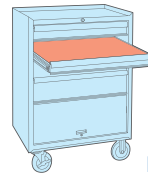

Drawer (579 x 380 mm)



9-2553MRV

Tray category #10 (375 x 140mm)

Contents

0.98 kg 1/6

	2335M	4, 5, 5.5, 6, 7, 8, 9, 10, 11, 12, 13, 14
	1025H	H3, H4, H5, H6, H7, H8, H10
	1025S	3, 4.5, 5, 6.5, 8
	1025P	PH0, PH1, PH2, PH3
	1025U	T10H, T15H, T20H, T25H, T27H, T30H, T40H
	1025Z	PZ1, PZ2, PZ3
	1025T	T10, T15, T20, T25, T27, T30, T40



53 PC.

Contents

	7702-25		2792		2813
	276A-04G		213312DF		
	2223-02		2223-04		2745

9-2553MRV01

Tray category #10 (375 x 140mm)

Contents

0.97 kg 1/6

	2335M	4, 4.5, 5, 5.5, 6, 7, 8, 9, 10, 11, 12, 13, 14
	1025H	H3, H4, H5, H6, H7, H8, H10
	1025T	T10, T15, T20, T25, T27, T30, T40
	1025U	T10H, T15H, T20H, T25H, T27H, T30H, T40H
	1025P	PH1, PH2, PH3
	1025Z	PZ1, PZ2, PZ3
	1025S	3, 4.5, 5, 6.5, 8



55 PC.

Contents

	7702-25		276A-04G
	2571-45		213312DF
	2221-02		2745
	2221-04		2792
	2221-06		2142

9-3523MRV10

Tray category #10 (375 x 140mm)

Contents

1.73 kg 1/6

	3335M	6, 7, 8, 9, 10, 11, 12, 13, 14, 15, 16, 17, 19, 21, 22, 23, 24	
	3771-08G		3792
	3571-08		3452-08F
	3293-03		3293-06



23 PC.

9-3523MRV11

9-3023MRV11

Tray category #10 (375 x 140mm)

KT NO.

Contents

1.09 kg 1/6

9-3523MRV11		3335M	6, 7, 8, 9, 10, 11, 12, 13, 14, 15, 16, 17, 18, 19, 21, 22, 24		3771-08G
					3293-03
					3293-06
					3453-08
9-3023MRV11		3330M	6, 7, 8, 9, 10, 11, 12, 13, 14, 15, 16, 17, 18, 19, 21, 22, 24		3571-08
					3792



9-3523MRV11

23 PC.



9-3023MRV11



Tool Set Content

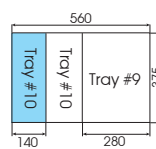
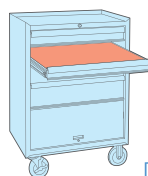

Drawer (579 x 380 mm)



9-4147PRV

Tray category #10 (375 x 140mm)

Contents

1.81 kg 1 / 5

	40D0	H6, H8, H10
	4066	M8, M9, M10, M12, M14
	4023	T20, T25, T27, T30, T40 T45, T50, T55, T60

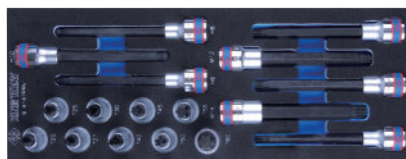

17 PC.

9-4401MPV

Tray category #10 (375 x 140mm)

Contents

2.23 kg 1 / 6

	4945M	17, 19, 21
	4535M	17, 19, 32, 34, 36
	4415M	17, 19, 21



11 PC.

9-90135MRV

Tray category #10 (375 x 140mm)

Contents

1.81 kg 1 / 6

	1930	8x10, 10x12, 11x13, 12x14, 17x19, 19x22
	1120MR	H1.5, H2, H2.5, H3, H4, H5, H6, H8, H10



15 PC.

9-90135SRV

Tray category #10 (375 x 140mm)

Contents

1.28 kg 1 / 6

	5930	5/16 x 3/8, 3/8 x 7/16, 1/2 x 9/16, 9/16 x 5/8, 11/16 x 3/4, 3/4 x 7/8
	1125SR	1/16, 5/64, 3/32, 1/8, 5/32, 3/16, 1/4, 5/16, 3/8



15 PC.

9-40104GPV

Tray category #10 (375 x 140mm)

Contents

1.08 kg 1 / 8

	6311-08		6111-06
	6231-07		6319-11C



4 PC.

9-40113GPV

Tray category #10 (375 x 140mm)

Contents

1.12 kg 1 / 8

	6011-10R		6516-10C		6314-05
--	----------	--	----------	--	---------



3 PC.

9-44214GPV

Tray category #10 (375 x 140mm)

Contents

1.08 kg 1 / 8

	67HS-07		67HB-07		68SS-07		68SB-07
--	---------	--	---------	--	---------	--	---------

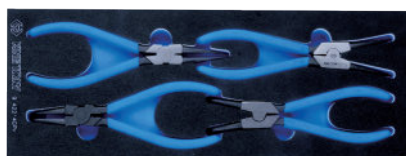

4 PC.

Tool Set Content

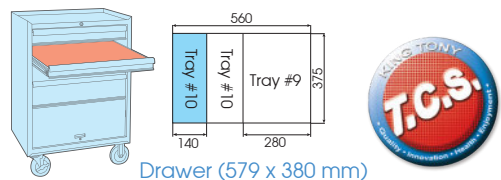

Drawer (579 x 380 mm)

9-30216MRV Tray category #10 (375 x 140mm)

Contents		kg 0.71	1/6
	1461 PH2 x 100, PH3 X 150		
	1462 5.5 X 100, 6.5 X 150		
	1411 PH2 x 38		
	1412 6.5 x 38		

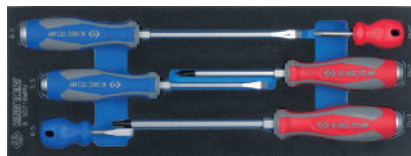

6 PC.

9-1044CQV Tray category #10 (375 x 140mm)

Contents		kg 1.75	1/6
	1636H H4, H5, H6, H7, H8, H10, H12		
	1680H H4, H5, H6, H7, H8, H10, H12		
	1636M M5, M6, M8, M10, M12		
	1680M M5, M6, M8, M10, M12		
	1636T T20, T25, T27, T30, T40, T45, T50, T55, T60		



44 PC.

Contents	
	1680T T20, T25, T27, T30, T40, T45, T50, T55, T60
	314810M
	414810M

9-90118PRV Tray category #10 (375 x 140mm)

Contents		kg 1.28	1/6
	76104-05		7821-30
	76217-06		76403-06
	76220-07		76404-06
			76405-65
			76406-07



8 PC.

9-90305TQV 9-90305TQV01 Tray category #10 (375 x 140mm)



5 PC.

9-90305TQV



9 PC.

9-90305TQV01

KT NO.	Contents		kg 0.91	1/6
9-90305TQV			7971-07	
	9BM120			77141-08
9-90305TQV01			77335-25	
	11205SQ			79093-05C

9-21-20-07MRV Tray category #10 (375 x 140mm)

Contents		kg 0.91	1/6	Each Q'ty
	4 x 8 mm		4 x 10 mm	20
	4 x 8 mm		4 x 10 mm	
	4.8 x 8 mm		4.8 x 10 mm	
	21-20-101			1



121 PC.



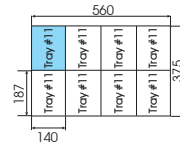
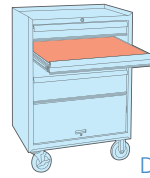

Drawer (579 x 380 mm)



Tool Set Content

9-2516MRV03 Tray category #11 (187 x 140mm)

Contents 0.47 1 / 12

2335M	4, 4.5, 5, 5.5, 6, 7, 8, 9, 10, 11, 12, 13, 14
2771-55G	2571-45
2221-06	2792

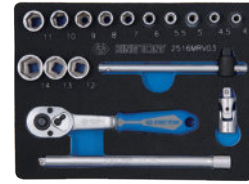

17 PC.

9-2524MRV Tray category #11 (187 x 140mm)

Contents 0.63 1 / 12

2335M	4, 4.5, 5, 5.5, 6, 7, 8, 9, 10, 11, 12, 13, 14
2771-55G	2571-45 2142
2221-02	2221-04
2221-06	2792 2178DF



21 PC.

9-2528MRV Tray category #11 (187 x 140mm)

Contents 0.48 1 / 12

2335M	4, 4.5, 5, 5.5, 6, 7, 8, 9, 10, 11, 12, 13, 14
1025H	H3, H4, H5, H6
1025S	4, 5
1025T	T10, T15, T20, T30
1025P	PH1, PH2
276A-04G	2792
2221-06	2142

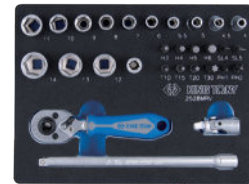

29 PC.

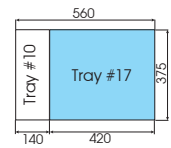
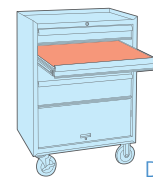

Drawer (579 x 380 mm)

9-91113SRV Tray category #17 (375 x 420mm)

Contents 3.65 1 / 5

5970	1/4 x 5/16, 3/8 x 7/16 1/2 x 9/16, 5/8 x 11/16 3/4 x 7/8, 15/16 x 1 1-1/16 x 1-1/8, 1-1/8 x 1-1/4 1-3/16 x 1-5/16
3812	2813 3814 4813



13 PC.

Tool Set Content

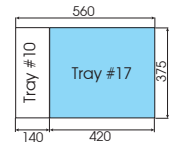
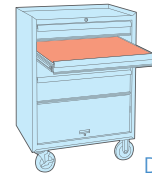

Drawer (579 x 380 mm)

Tray category #17 (375 x 420mm)



32 PC.

Contents	3.96 kg	1 / 4
4335VE 8, 10, 11, 12, 13, 14, 15, 16, 17, 18, 19, 20, 21, 22, 24, 27, 30, 32		
4025VE H4, H5, H6, H8, H10		
4035VE H4, H5, H6, H8, H10		
4251VE 5, 10		
4771VE-10 4178VE-08		





Fill Your Drawer

How to complete your tool trolley set and tool chest set

The drawer of tool chest includes one top drawer and different size



- Do not move the box / trolley unit unless you have closed the cover and locked the drawers
- Never open more than one loaded drawer at the same time
- Watch for sharp edges, we suggest to put on gloves before you lift the unit

Drawer (646x290 mm)

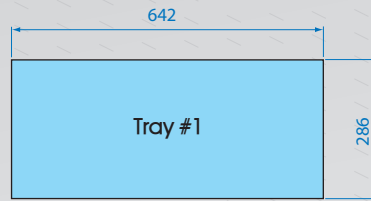
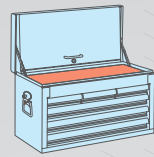

Drawer (172x275 mm)

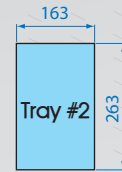
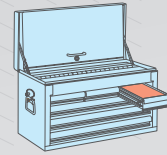

Drawer (572x275 mm)

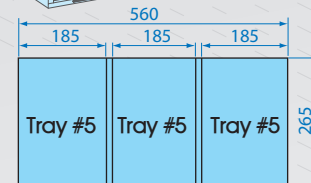
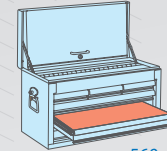
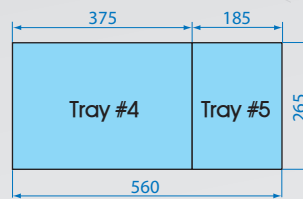
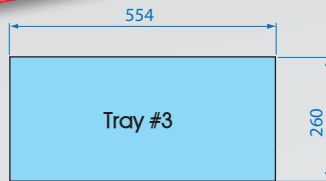
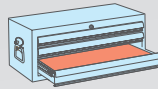

Drawer (579x380 mm)

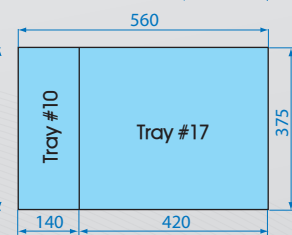
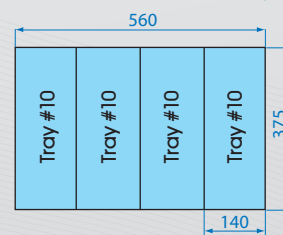
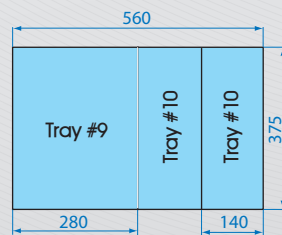
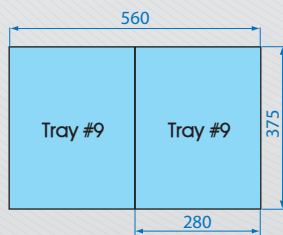
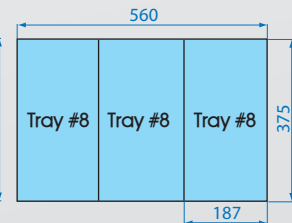
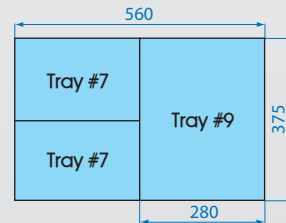
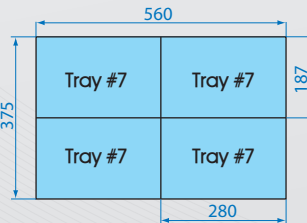
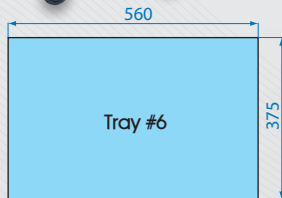
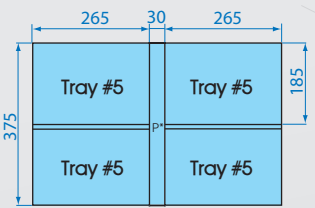
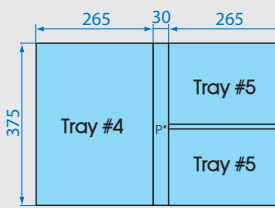
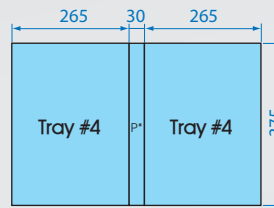
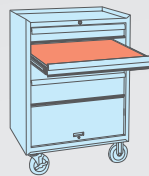

Drawer (504 x 195 mm)

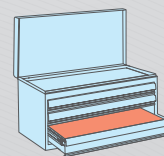
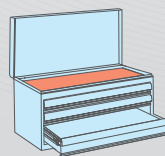

87402 Drawer (470 x 220 mm) #14
87408 Drawer (530 x 220 mm) #15

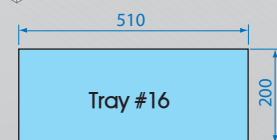
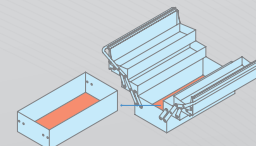
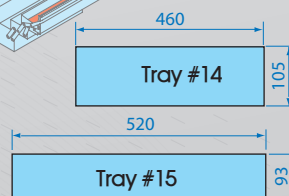
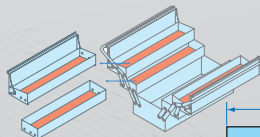

Tool Trolley Contents

101 PC.



Contents No. 932-009MRD

19.80 CUFT 2.41



9-4333MR #4 P.114



9-4120PR #5 P.123
9-4119PR #5 P.123

84700612B



9-1219MR01 #4 P.116



9-1711MR #4 P.118

84700612B



9-90106SR #4 P.121



9-40103GP #5 P.124

84700612B



1110MR P.326



34423-1A P.305

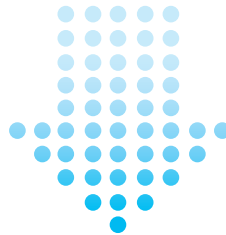

Tool Trolley Set

101 PC.



75.8
CUFT 14.65



932-009MR
(87432-5B P.37)



932-009MR-G
(87432-5B-G P.37)



932-009MR-B
(87432-5B-B P.37)



85.94
CUFT 18.05



9634-009MR
(87634-7B P.38)



9634-009MR-G
(87634-7B-G P.38)



9634-009MR-B
(87634-7B-B P.38)





Tool Trolley Contents

144 PC.



Contents No. 932-010MRD

17.50 CUFT 1.86



9-4328MR #4 P.114
84700612B



9-5575MR #4 P.115



9-1216MR01 #4 P.116



9-1709MR #4 P.117
84700612B



9-90106SR #4 P.121



9-31106MR #5 P.124
9-40103GP #5 P.124
84700612B



34423-1A P.305

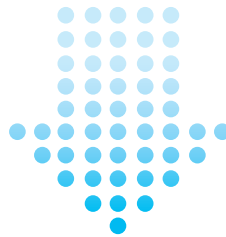

Tool Trolley Set

144 PC.



73.5
CUFT 14.1



932-010MR
(87432-5B P.37)



932-010MR-G
(87432-5B-G P.37)



932-010MR-B
(87432-5B-B P.37)



83.64
CUFT 17.5



9634-010MR
(87634-7B P.38)



9634-010MR-G
(87634-7B-G P.38)



9634-010MR-B
(87634-7B-B P.38)

Tool Trolley Contents

170 PC.



Contents No. 941-101MRD

24.80 KUFT 2.54

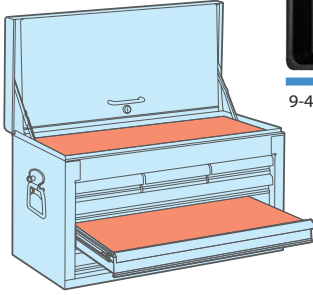

9-4026MR02 #1 P.110



9-3023MR01 #4 P.114

9-2526MR #5 P.123

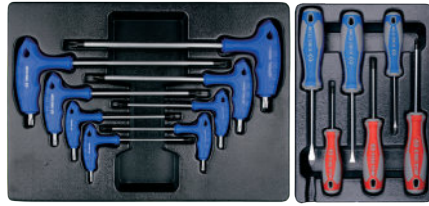

9-22308PR #4 P.121

9-31106MR #5 P.124



9-4120PR #5 P.123

9-4119PR #5 P.123

9-1303MR #5 P.123

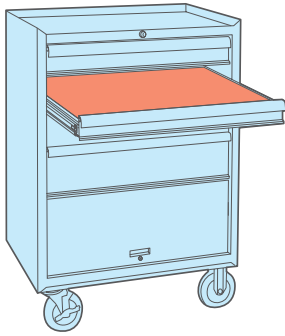

9-1711MR #4 P.118

84700612B

9-1216MR #4 P.116



9-90103RR #4 P.121

9-20110MR #5 P.124

84700612B

9-40103GP #5 P.124



9-4128FR #5 P.124



1010PR P.473

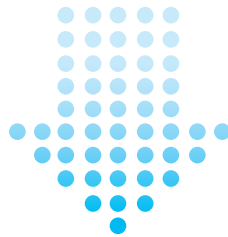

Tool Trolley Set

170 PC.



106.2 KUFT 18.31



941-101MR
(87411-6B P.48)
(87432-5B P.37)



125.2 KUFT 19.21



9644-101MR
(87411-6B P.48)
(87634-7B P.38)



Tool Trolley Contents

173 PC.



Contents No. 932-000MRD

24.70 CUFT 2.10



9-4333MR #4 P.114
84700612B



9-7540MR #4 P.115



9-1216MR01 #4 P.116



9-1711MR #4 P.118



9-90131MR #4 P.116



9-31110MR #4 P.84

84700612B



9-22108MR #4 P.121
84700612B

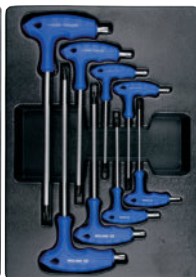

9-22308PR #4 P.121



9-90103PP #4 P.121

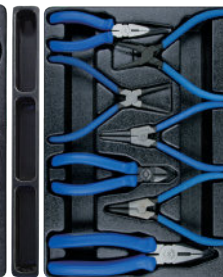

9-40207GP #4 P.120

84700612B



1006PR #4 P.473



Tool Trolley Set

173 PC.



80.70
CUFT 14.34



932-000MR
(87432-5B P.37)



932-000MR-G
(87432-5B-G P.37)



932-000MR-B
(87432-5B-B P.37)

Tool Trolley Contents

179 PC.



Contents No. 932-008MRD

20.52 CUFT 2.41



9-4522MR #4 P.113 84700612B 9-3523MR #4 P.114 9-1219MR01 #4 P.116 84700612B 9-90315MR #4 P.118 9-91120MR #4 P.119 84700612B 9-31909PR #4 P.122



9-90103PP01 #4 P.121 84700612B 9-40207GP #4 P.120 9-4120PR #5 P.123 9-31106MR #5 P.124 9-4119PR #5 P.123 84700612B 9-2526MR #5 P.123 1010PR #4 P.473 9DC23 P.597

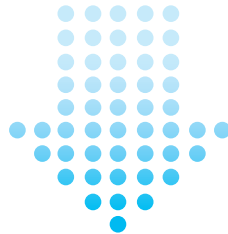

Tool Trolley Set

179 PC.



76.52
CUFT 14.65



932-008MR
(87432-5B P.37)



932-008MR-G
(87432-5B-G P.37)



932-008MR-B
(87432-5B-B P.37)



86.66
CUFT 18.05



9634-008MR
(87634-7B P.38)



9634-008MR-G
(87634-7B-G P.38)



9634-008MR-B
(87634-7B-B P.38)





Tool Trolley Contents

197 PC.



Contents No. 934-001MRD

28.70 CUFT 3.70



9-90408TQ #6 P.125



9-4516MR #4 P.113

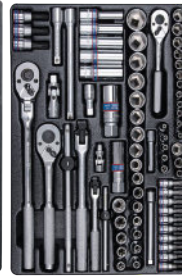

9-5575MR #4 P.115



9-1711MR #4 P.118



9-1218MR #4 P.116

84700612B

84700612B



9-22108MR #4 P.121



9-31909PR #4 P.122

84700612B



9-90310MR #4 P.122



9-90106SR #4 P.121

84700612B



9-90205GN01 #4 P.120



9-4128FR #5 P.124

84700612B

9-40103GP #5 P.124



7962-04 P.478



2121-18 P.605

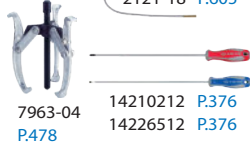

7963-04 P.478

14210212 P.376
14226512 P.376



42114GP P.344



1108MR P.326



Tool Trolley Set

197 PC.

92.7 CUFT 15.94

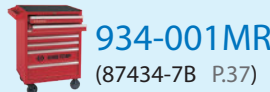

934-001MR (87434-7B P.37)

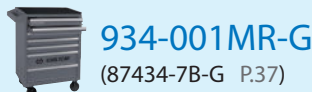

934-001MR-G (87434-7B-G P.37)

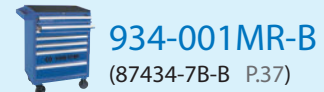

934-001MR-B (87434-7B-B P.37)

94.84 CUFT 15.94

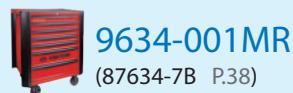

9634-001MR (87634-7B P.38)

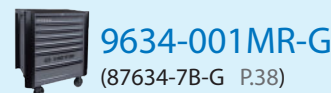

9634-001MR-G (87634-7B-G P.38)

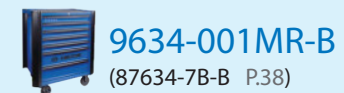

9634-001MR-B (87634-7B-B P.38)



Tool Chest Set

69 PC.

901-068MR 18.80 CUFT 2.05

901-069MR 18.40 CUFT 2.05



9-4338MR #11 P.130 (901-069MR use)



9-4338MR01 #11 P.130 (901-068MR use)



9-90121MR #12 P.130



9-90104GP #12 P.130



87401-3 P.49

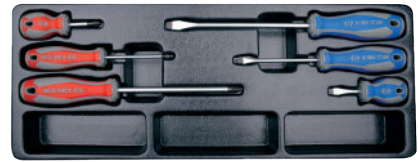

9-31006MR #12 P.131

Tool Chest Set

74 PC.

901-073MR 19.50 CUFT 2.05



9-4338MR03 #11 P.130



9-90126MR #12 P.130



9-90104GP #12 P.130



87401-3 P.49

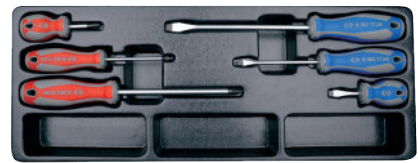

9-31006MR #12 P.131



Tool Chest Set

219 PC.

911-000CR

50.50 CUFT 6.10

911-000CR02

50.80 CUFT 6.10



9-7069CR #1 110 (911-000CR use)

9-7069CR01 #1 P.110 (911-000CR02 use)



87411-6B P.48



9-90129CR #3 P.112



9-90138CR #3 P.112



9-2548CR #2 P.111 (911-000CR use)



9-2548CR01 #2 P.111 (911-000CR02 use)

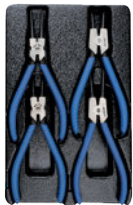

9-42114GP #2 P.111



9-40102GP #2 P.111



9-90128SR #3 P.111

Tool Chest Set

107 PC.

911-002CR

40.50 CUFT 5.12



87411-6B P.48



7811-16 P.470



4042CR #476 x 282mm P.202



20107SR P.414 20109MR P.414



9-42144GP #4 P.120



9-31106MR #5 P.124



9-90138CR #3 112

Tool Chest Set

235 PC.

911-003CR

46.16 CUFT 6.10

911-003CR01

46.16 CUFT 6.10



9-7078CR #1 P.110 (911-003CR use)



9-7078CR01 #1 P.110 (911-003CR01 use)



9-90220MR #3 P.112 (911-003CR use)



9-90220MR01 #3 P.112 (911-003CR01 use)



9-90154CR #3 P.113 (911-003CR use)



9-90154CR01 #3 P.113 (911-003CR01 use)



87411-6B P.48



9-90329CR #3 P.112



9-2548CR01 #2 P.111 (911-003CR use)



9-2548CR #2 P.111 (911-003CR01 use)

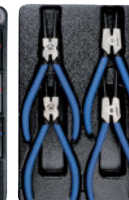

9-42114GP #2 P.111



9-40102GP #2 P.111





Tool Box Contents

62 PC.



Contents No. 902-062MRD

8.80 KU KUFT 1.22



9-4116FR #14 P.132

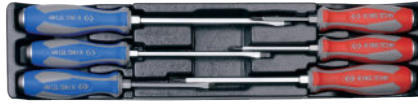

9-30206MR #14 P.132



9-1217MR #14 P.132



9-4319MR #14 P.131



9-90120MR #14 P.132



9-40203GP #14 P.132



Tool Box Set

62 PC.

14.4 KU KUFT 1.22



902-062MR (87402 P.50)

13.9 KU KUFT 1.22



9A05-062MR (87A05 P.50)



9A05-062MR-KB (87A05-KB P.50)

Tool Box Contents

63 PC.



Contents No. 902-164MRD

10.20 KU KUFT 1.22



9-4116FR #14 P.132



9-4219MR #14 P.131

- 1060 P.322 8, 10, 12, 13, 14, 17, 19, 21, 22, 24
- 1120MR P.414 H1.5, H2, H2.5, H3, H4, H5, H6, H8, H10
- 1421 P.376 PH1 x 80, PH2 x 38, PH3 x 150
- 1422 P.376 5.5 x 100, 6.5 x 38, 8 x 175

- 6111-07 P.353 76217-06 P.472 76223-08 P.472
- 6311-06 P.354 76403-05 P.472 76404-06 P.472 76405-65 P.472 76406-07 P.472
- 6511-10 P.356 76104-05 P.471
- 3611-08R P.342 7811-16 P.470



Tool Box Set

63 PC.

15.8 KU KUFT 1.22



902-164MR (87402 P.50)

15.3 KU KUFT 1.22



9A05-164MR (87A05 P.50)



9A05-164MR-KB (87A05-KB P.50)

Tool Box Contents

65 PC.



Contents No. 902-065MRD

9.10 CUFT 1.22



9-4116FR #14 P.132



9-4319MR #14 P.131



9-90115MR #14 P.132



9-1716MR #14 P.132

- ⊕ 1421 P.376 PH1 x 80, PH2 x 38, PH3 x 150
- ⊖ 1422 P.376 5.5 x 100, 6.5 x 38, 8 x 175

- 6111-07 P.353
- 6311-06 P.354
- 6511-10 P.356
- 3611-08P P.342
- 76104-05 P.471
- 76217-06 P.472
- 76223-08 P.472
- 76403-05 P.472
- 76404-06 P.472
- 76405-65 P.472
- 76406-07 P.472
- 7811-16 P.470

Tool Box Set

65 PC.



14.7 CUFT 1.22



902-065MR (87402 P.50)

14.2 CUFT 1.22



9A05-065MR (87A05 P.50)



9A05-065MR-KB (87A05-KB P.50)

Tool Box Contents

68 PC.



Contents No. 902-068MRD

10.30 CUFT 1.22



9-4116FR #14 P.132



9-4319MR01 #14 P.131

- 1060 P.322 8, 10, 11, 12, 13, 14, 15, 16, 17, 18, 19, 21, 22, 24
- 1120MR P.414 H1.5, H2, H2.5, H3, H4, H5, H6, H8, H10
- ⊕ 1421 P.376 PH1 x 80, PH2 x 38, PH3 x 150
- ⊖ 1422 P.376 5.5 x 100, 6.5 x 38, 8 x 175

- 7911-12 P.494
- 76217-06 P.472
- 76223-08 P.472
- 76403-05 P.472
- 76404-06 P.472
- 76405-65 P.472
- 76406-07 P.472
- 7821-30 P.470
- 6111-07 P.353
- 6311-06 P.354
- 6511-10 P.356
- 3611-12P P.342
- 76104-05 P.471

Tool Box Set

68 PC.



15.9 CUFT 1.22



902-068MR (87402 P.50)

15.4 CUFT 1.22



9A05-068MR (87A05 P.50)



9A05-068MR-KB (87A05-KB P.50)



Tool Box Contents

81 PC.



Contents No. 902-084MRD01

13.60 CUFT 1.22



9-4116FR03 #14 P.132



9-4219MR07 #14 P.131



1215MR P.323

- 4230M P.179 16, 17, 18, 19, 20, 21, 22, 24, 25, 26
- 1421 P.376 PH1 x 100, PH2 x 150, PH3 x 150
- 1422 P.376 6.5 x 100, 6.5 x 150, 8 x 150
- 6231-07 P.353 6311-06 P.354
- 6463-08C P.355 6516-10C P.355

- 6031-07R P.360 76104-05 P.471
- 3611-08R P.342 76105-06 P.471
- 3611-12R P.342 76213-04 P.472
- 20218MR P.412 76215-05 P.472
- 7851-16 P.471 76220-07 P.472
- 7811-16 P.470 76306-05 P.471
- 76403-05 P.472
- 76404-06 P.472



Tool Box Set

81 PC.

19.24
CUFT 1.22



902-084MR01
(87402 P.50)

18.74
CUFT 1.22



9A05-084MR01
(87A05 P.50)



9A05-084MR01-KB
(87A05-KB P.50)

Tool Box Contents

84 PC.



Contents No. 902-084SRD

15.90 CUFT 1.22



9-4116FR03 #14 P.132



9-4219SR08 #14 P.131



1216SR P.323

- 4230S P.179 1/2, 9/16, 5/8, 11/16, 3/4, 13/16, 7/8, 15/16, 1, 1-1/16, 1-1/8, 1-1/4
- 1421 P.376 PH1 x 100, PH2 x 150, PH3 x 150
- 1422 P.376 6.5 x 100, 6.5 x 150, 8 x 150
- 6231-07 P.353 6311-06 P.354
- 6463-08C P.355 6516-10C P.355
- 20107SR P.414 6031-07R P.360

- 3611-08R P.342 76104-05 P.471
- 3611-12R P.342 76105-06 P.471
- 7811-16 P.470 76213-04 P.472
- 7851-16 P.471 76215-05 P.472
- 76220-07 P.472
- 76306-05 P.471
- 76403-05 P.472
- 76404-06 P.472



Tool Box Set

84 PC.

21.55
CUFT 1.22



902-084SR
(87402 P.50)

21.0
CUFT 1.22



9A05-084SR
(87A05 P.50)



9A05-084SR-KB
(87A05-KB P.50)

Tool Box Contents

88 PC.



Contents No. 902-089MRD01

13.90 KG 1.22 CUFT















9-4116FR #14 P.132



9-4319MR01 #14 P.131



1812MR P.341

 1060 P.322	6, 7, 8, 9, 10, 11, 12, 13, 14, 15, 16, 17, 18, 19, 20, 21, 22, 24	 1421 P.367	PH2 x 38, PH3 x 150
 1900 P.326	6 x 7, 8 x 10, 11 x 13, 12 x 13, 17x19, 22 x 24	 1422 P.367	3 x 75, 5 x 100
 1120MR P.414	H1.5, H2, H2.5, H3, H4, H5, H6, H8, H10	 6111-07 P.353	 3611-08R P.342
 1147R P.416	T10H, T15H, T20H, T25H, T27H, T30H, T40H	 6311-06 P.354	 7911-12 P.494
		 6516-10C P.355	 7821-80 P.470

Tool Box Set

88 PC.



19.5 KG 1.22 CUFT



902-089MR01 (87402 P.50)

19.0 KG 1.22 CUFT



9A05-089MR01 (87A05 P.50)



9A05-089MR01-KB (87A05-KB P.50)

Tool Box Contents

103 PC.



Contents No. 902-103MRD

19.20 KG 1.22 CUFT



9-4116FR #14 P.132



9-4319MR01 #14 P.131



1812MR P.341

 1060 P.322	8, 9, 10, 11, 12, 13, 14, 15, 16, 17, 18, 19, 21, 22, 23, 24, 27, 30, 32	 6111-07 P.353	 7911-12 P.494
 1120MR P.414	H1.5, H2, H2.5, H3, H4, H5, H6, H8, H10	 6311-06 P.354	 7821-80 P.470
 1147R P.416	T10H, T15H, T20H, T25H, T27H, T30H, T40H	 6516-10C P.355	 76220-07 P.472
 1421 P.376	PH0 x 60, PH1 x 100, PH2 x 100, PH3 x 150	 6231-08 P.353	 76226-12 P.472
 1422 P.376	3 x 75, 4 x 100, 5 x 75, 5.5 x 125, 6.5 x 150, 8 x 175	 6431-10 P.355	 76402-45 P.472
		 6011-10R P.360	 76403-05 P.472
		 3611-12R P.342	 76404-06 P.472
		 79093-03C P.482	 76405-65 P.472
			 76406-07 P.472
			 76408-08 P.472
			 76412-09 P.472
			 76414-10 P.472

Tool Box Set

103 PC.



24.8 KG 1.22 CUFT



902-103MR (87402 P.50)

24.3 KG 1.22 CUFT



9A05-103MR (87A05 P.50)



9A05-103MR-KB (87A05-KB P.50)



Tool Box Contents

109 PC.



Contents No. 902-109MRD

19.40 CUFT 1.22



9-4116FR #14 P.132



9-4319MR01 #14 P.131



1812MR P.341



1306MR P.332

- | | | | |
|--------------|--|-----------------|--|
| 1060 P.322 | 8, 9, 10, 11, 12, 13, 14, 15, 16, 17, 18, 19, 21, 22, 23, 24, 27, 30, 32 | 6111-07 P.353 | 7911-12 P.494 |
| 1120MR P.414 | H1.5, H2, H2.5, H3, H4, H5, H6, H8, H10 | 6311-06 P.354 | 7811-16 P.470 |
| 1147R P.416 | T10H, T15H, T20H, T25H, T27H, T30H, T40H | 6516-10C P.355 | 76220-07 P.472
76226-12 P.472 |
| 1421 P.376 | PH0 x 60, PH1 x 100, PH2 x 100, PH3 x 150 | 6232-08 P.353 | 76402-45 P.472
76403-05 P.472
76404-06 P.472
76405-65 P.472
76406-07 P.472
76408-08 P.472
76412-09 P.472
76414-10 P.472 |
| 1422 P.376 | 3 x 75, 4 x 100, 5 x 75, 5.5 x 125, 6.5 x 150, 8 x 175 | 6431-10 P.355 | |
| | | 6011-10R P.360 | |
| | | 3611-12R P.342 | |
| | | 79093-05C P.482 | |

Tool Box Set

109 PC.



24.99 CUFT 1.22



902-109MR
(87402 P.50)

24.5 CUFT 1.22



9A05-109MR
(87A05 P.50)



9A05-109MR-KB
(87A05-KB P.50)

Tool Box Contents

132 PC.



Contents No. 902-132CRD

24.50 CUFT 1.51



9-4116FR #14 P.132

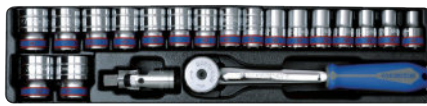

9-4319MR01 #14 P.131



1812MR P.341



1226MR P.323

- | | | | | | |
|--------------|--|-----------------|---------------|----------------------------------|----------------------------------|
| 1005GQ P.495 | 30617MR P.432 | 20208MR01 P.413 | 11205SQ P.489 | 6111-07 P.353 | 7911-12 P.494 |
| 1421 P.376 | PH0 x 60, PH1 x 100, PH2 x 100, PH3 x 150 | | | 6311-06 P.354 | 7811-12 P.470 |
| 1422 P.376 | 3 x 75, 4 x 100, 5 x 75, 5.5 x 125, 6.5 x 150, 8 x 175 | | | 6516-10C P.355 | 76104-05 P.471
76220-07 P.472 |
| | | | | 6231-07 P.353 | 6011-10R P.360 |
| | | | | 6721-10 P.465 | 2121-18 P.605 |
| | | | | 6711-06 P.355 | 7971-07 P.458 |
| | | | | 3611-08P P.342
3611-12P P.342 | 79093-03C P.482 |
| | | | | 20419PR P.417 | |

Tool Box Set

132 PC.



30.1 CUFT 2.73



902-132CR
(87402 P.50)

29.1 CUFT 2.92



9A05-132CR
(87A05 P.50)



9A05-132CR-KB
(87A05-KB P.50)

Tool Box Contents

77
PC.



Contents No. 908-077CRD

19.80 CUFT 0.99



9-4029CR #15 P.133



9-90111MR #15 P.133



9-4156PR #15 P.133



9-30206MR #14 P.132



9-1215MR03 #16 P.133



9-6010MR #16 P.133



Tool Box Set

77
PC.

26.52
CUFT 2.29



908-077CR
(87408 P.50)





Tool Box Contents

25 PC.



Contents No. 41026MRD

3.96 CUFT 0.78

- 

4330MR [P.178](#)
10, 11, 12, 13, 14, 15,
16, 17, 18, 19, 20, 21,
22, 23, 24, 27, 30, 32
- 

463021RC [P.182](#)
- 
4791R [P.192](#)
- 
4452-15FR [P.190](#)
- 
4768-10F [P.186](#)
- 
4572-12 [P.191](#)
- 
4251-05R [P.190](#)
4251-10R [P.190](#)



Tool Box Set

25 PC.

5.7 CUFT 0.78



41026MR
(87407 P.50)

Tool Box Contents

25 PC.



Contents No. 41526MRD

3.96 CUFT 0.78

- 

4335MR [P.178](#)
10, 11, 12, 13, 14, 15,
16, 17, 18, 19, 20, 21,
22, 23, 24, 27, 30, 32
- 

463521RC [P.182](#)
- 
4791R [P.192](#)
- 
4452-15FR [P.190](#)
- 
4768-10F [P.186](#)
- 
4572-12 [P.191](#)
- 
4251-05R [P.190](#)
4251-10R [P.190](#)



Tool Box Set

25 PC.

5.7 CUFT 0.78



41526MR
(87407 P.50)









Tool Box Contents

17 PC.





Contents No. 41517MRVD 2.26 CUFT 0.91

-   4335MR P.178 10, 11, 13, 14, 15, 16, 17, 18, 19, 21, 22, 24
-  4771-10GR P.186
-  4791R P.192
-  4251-05R P.190
-  3611-08R P.342
-  6111-06 P.353



Tool Box Set

17 PC.















 4.26  **41517MRV**
CUFT 0.91 (87A08 P.50)

Tool Box Contents

42 PC.





Contents No. 41542MRVD 4.65 CUFT 0.91

-   4335MR P.178 10, 11, 13, 14, 15, 16, 17, 18, 19, 21, 22, 24
-   1421 P.376 PH0 x 60, PH1 x 80, PH2 x 100
-   1422 P.376 3 x 75, 5.5 x 100, 6.5 x 150
-   1130MR P.414 H2.5, H3, H4, H5, H6, H8, H10
-  1062 P.320 8, 9, 10, 11, 12, 13, 14, 17, 18, 19, 22, 24
-  4251-05R P.190
-  3611-08R P.342
-  6111-06 P.353
-  4771-10GR P.186
-  4791R P.192



Tool Box Set

42 PC.

 6.65  **41542MRV**
CUFT 0.91 (87A08 P.50)

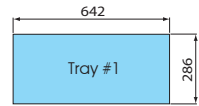

Tool Set Content

9-4526MR

9-4026MR02 Tray category #1 (642 x 286mm)



9-4526MR



9-4026MR02

24 PC.

KT NO.	Contents		kg 4.6	1 / 5
9-4526MR	4335MR	10, 11, 12, 13, 14, 15, 16, 17, 18, 19, 20, 21, 22, 23, 24, 27, 30, 32	463521RC	4768-10F
9-4026MR02	4330MR		463021RC	4768-10P
			4572-12	4251-05R 4251-10R
			4452-15FR	

9-7069CR

9-7069CR01 Tray category #1 (642 x 286mm)



9-7069CR



9-7069CR01

70 PC.



KT NO.	Contents		kg 8.8	1 / 2
9-7069CR	3779-08G	3330M 6, 7, 8, 9, 10, 11, 12, 13, 14, 15, 16, 17, 19, 20, 21, 22	463521RC	463516RC
	4779-10GR	3330S 3/8, 7/16, 1/2, 9/16, 5/8, 11/16, 3/4, 13/16	3452-08F	4452-15FR
9-7069CR01	3769-08P	4330MR 10, 11, 12, 13, 14, 15, 16, 17, 18, 19, 20, 21, 22, 23, 24, 27, 30, 32	4572-10	3221-03 3221-06
	4768-10P	4330SR 3/8, 7/16, 1/2, 9/16, 5/8, 11/16, 3/4, 13/16, 7/8, 15/16, 1	3792	4791R
			3812	4813
				7911-12

9-7078CR

9-7078CR01 Tray category #1 (642 x 286mm)



9-7078CR



9-7078CR01

78 PC.

KT NO.	Contents		kg 8.67	1 / 2
9-7078CR	3769-08P	3330M 8, 9, 10, 11, 12, 13, 14, 15, 16, 17, 18, 19, 20, 21, 22	3235M 10, 12, 13, 14, 15, 16, 17, 18, 19, 22	363516
	4768-10P	3330S 3/8, 7/16, 1/2, 9/16, 5/8, 11/16, 3/4, 13/16	4462-18F	3221-03 3221-10
9-7078CR01	3779-08G	4330MR 10, 11, 12, 13, 14, 15, 16, 17, 18, 19, 20, 21, 22, 23, 24, 25, 27, 28, 30, 32	4251-05R	4251-10R
	4779-10GR	4330SR 3/8, 7/16, 1/2, 9/16, 5/8, 11/16, 3/4, 13/16, 7/8, 15/16, 1, 1-1/8, 1-1/4	3792	4791R
			3812	4813

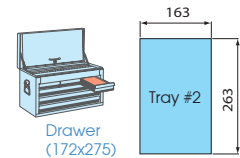

Tool Set Content

9-2548CR

9-2548CR01 Tray category #2 (263 x 163mm)













9-2548CR



9-2548CR01

48 PC.

KT NO.	Contents		kg 1.28	1 / 10	
9-2548CR	 2779-55G	 4, 5, 5.5, 6, 7, 8, 9, 10, 11, 12, 13  5/32, 3/16, 7/32, 1/4, 9/32, 5/16, 11/32, 3/8, 7/16, 1/2	 4, 4.5, 5, 5.5, 6, 7, 8, 9, 10, 11, 12, 13  5/32, 3/16, 7/32, 1/4, 9/32, 5/16, 11/32, 3/8, 7/16, 1/2		
9-2548CR01	 2769-55P	 2792  2813  2221-02  2221-04			

9-40102GP

9-42114GP Tray category #2 (263 x 163mm)





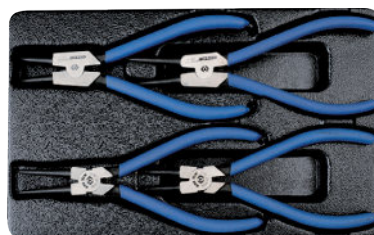

2 PC.



4 PC.





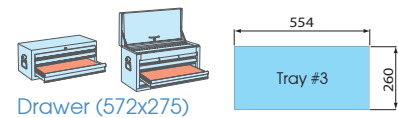





Contents	kg 1.0	1 / 10
 6011-10R	 6511-10	

Contents		kg 0.6	1 / 10
 68HS-07	 68SS-07		
 68HB-07	 68SB-07		



9-90128SR

Tray category #3 (554 x 260mm)

Contents		kg 4.8	1 / 4
 5060	1/4, 5/16, 3/8, 7/16, 1/2, 9/16, 5/8, 11/16, 3/4, 13/16, 7/8, 1		
 5970	1/4 x 5/16, 3/8 x 7/16, 1/2 x 9/16, 5/8 x 11/16, 3/4 x 7/8, 15/16 x 1, 1-1/16 x 1-1/8		
 76105-06	 7811-16		
 76215-05  76217-06  76220-07  76224-10	 76404-06  76406-07  76408-08		



28 PC.



Tool Set Content

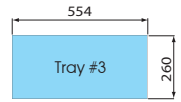
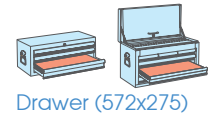

9-90138CR

Tray category #3 (554 x 260mm)

Contents

4.8 kg 1/4

	1060	6, 7, 8, 9, 10, 11, 12, 13, 14, 15, 16, 17, 19, 20, 21
	1900	8 x 9, 10 x 11, 12 x 13, 14 x 15, 18 x 19
	1970	6 x 7, 8 x 9, 10 x 11, 12 x 13, 14 x 15, 16 x 17, 18 x 19
	1930	10 x 11, 12 x 14, 14 x 17
	5900	1/4 x 5/16, 3/8 x 7/16, 7/16 x 1/2, 9/16 x 5/8, 11/16 x 3/4, 13/16 x 7/8
	3611P	8, 12



38 PC.

9-90329CR

Tray category #3 (554 x 260mm)

Contents

3.37 kg 1/4

	1060	6, 7, 8, 10, 11, 12, 13, 14, 15, 16, 17, 18, 19, 21
	5060	7/16, 1/2, 9/16, 5/8, 11/16, 3/4
	10D0	10, 12, 13, 14, 17, 18, 19
	3611R	6, 8



29 PC.

9-90129CR

Tray category #3 (554 x 260mm)

Contents

2.5 kg 1/4

	1421	PH0 x 60, PH1 x 80, PH2 x 38, PH2 x 100, PH3 x 150
	1422	3 x 75, 6.5 x 38, 6.5 x 100, 6.5 x 150, 8 x 175
	1130SR	3/32, 1/8, 5/32, 3/16, 1/4, 5/16, 3/8
	1120MR	H1.5, H2, H2.5, H3, H4, H5, H6, H8, H10
	6111-07	6231-07
	6311-06	



29 PC.

9-90220MR



9-90220MR

9-90220MR01

Tray category #3 (554 x 260mm)



9-90220MR01

20 PC.

KT NO.

Contents

2.51 kg 1/4

9-90220MR		14280204		3025	H3, H4, H5, H6, H8, H10, H12		1421	PH1x80, PH2x100
		14240206		3023	T30, T40		1422	4x100, 5.5x125, 6.5x150, 8x175
9-90220MR01		14232004		6111-08		6232-08		6311-08
		14232504						



Tool Set Content

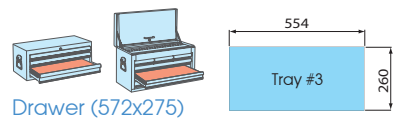

9-90154CR

9-90154CR01 Tray category #3 (554 x 260mm)

KT NO.	PC.	Contents	kg 2.86	1 / 4
9-90154CR	54	1032CQ01	<ul style="list-style-type: none"> 1130MR H2.5, H3, H4, H5, H6, H8, H10 1130SR 3/32, 1/8, 5/32, 3/16, 1/4, 5/16, 3/8 	
9-90154CR01	53	1032CQ	<ul style="list-style-type: none"> 7811-16 74030 76717-05 761 Ø 4 x 120 764 Ø 3 x 125, Ø 4 x 150, Ø 5 x 165 	

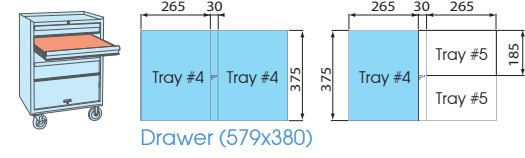
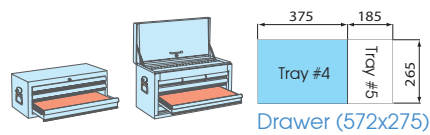

9-4516MR Tray category #4 (375 x 265mm)

Contents		kg 3.12	1 / 10
4335MR	8, 10, 11, 12, 13, 14, 17, 19, 21, 23, 24		
4791R	4768-10F	4452-15FR	
4251-05R	4251-10R		



16 PC.

9-4522MR Tray category #4 (375 x 265mm)

Contents		kg 2.96	1 / 10
4335MR	8, 10, 11, 12, 13, 14, 15, 16, 17, 18, 19, 20, 21, 22, 24		
463521RC	463516RC	4791R	
4768-10F	4251-03R, 4251-05R, 4251-10R		



22 PC.

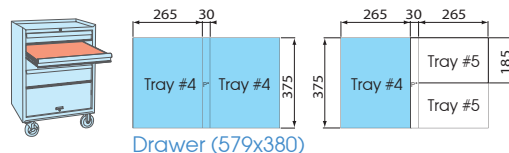
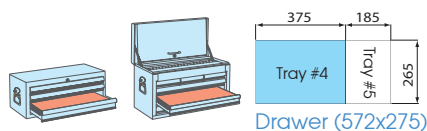

Tool Set Content

9-3523MR

9-3023MR01 Tray category #4 (375 x 265mm)



9-3523MR



9-3023MR01

22
PC.

KT NO.	Contents	kg 1.38 1 / 10		
9-3523MR	3335M 6, 7, 8, 9, 10, 11, 12, 13, 14, 15, 16, 17, 19, 20, 21, 22	3769-08F	3221-03 3221-06	3452-08F
9-3023MR01	3330M	3769-08P	3792	3571-08

9-4328MR Tray category #4 (375 x 265mm)

Contents	kg 4.6 1 / 6	
4335MR 8, 9, 10, 11, 12, 13, 14, 15, 16, 17, 18, 19, 20, 21, 22, 23, 24, 27, 29, 32		
4027 T55H, T60H		
4791R 4768-10F 4452-15FR		
4572-10 4251-05R 4251-10R		



28
PC.

9-4333MR

9-4333MR03 Tray category #4 (375 x 265mm)



9-4333MR



9-4333MR03

33
PC.

KT NO.	Contents	kg 5.4 1 / 6		
9-4333MR	4755-10G 4335MR 8, 9, 10, 11, 12, 13, 14, 15, 16, 17, 18, 19, 20, 21, 22, 23, 24, 25, 26, 27, 28, 29, 30, 32			
9-4333MR03	4779-10GR 463521RC 463516RC 4791R 4572-12 4452-15FR 4251-03R 4251-05R 4251-10R			

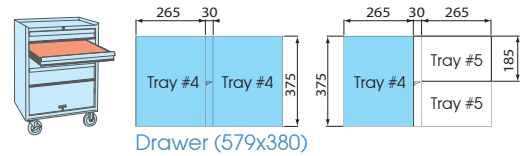
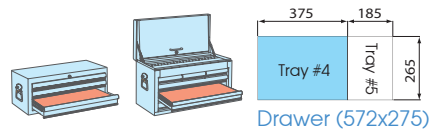

Tool Set Content

9-5575MR Tray category #4 (375 x 265mm)

Contents		4.15	1 / 6
	2335M	4, 4.5, 5, 5.5, 6, 7, 8, 9, 10, 11, 12, 13	
	2335S	1/4, 3/8, 1/2	
	3235M	8, 10, 12, 14, 17	
	3335M	6, 7, 8, 9, 10, 11, 12, 13, 14, 15, 16, 17, 18, 19, 21, 22	
	2375M	E4, E5, E6, E7, E8	
	3375M	E10, E12, E14, E16, E18	
	2037	T10H, T15H, T20H, T25H, T27H, T30H	
	2033	T20, T25, T30, T40	
	3027	T40H, T45H, T50H	



75 PC.

Contents		
	366516	
	366521	
	3221-16	
	2769-55F	
	3769-08F	
	3781-11F	
	2221-02	
	2221-04	
	3221-03	
	3221-06	
	2571-45	
	2452-05F	
	3452-08F	
	3571-08	
	2792	
	3792	

9-7537MR Tray category #4 (375 x 265mm)

Contents		2.28	1 / 6
	2335M	4, 4.5, 5, 5.5, 6, 7, 8, 9, 10, 11, 12, 13	
	4023	T20, T25, T27, T30, T40, T45, T50, T55, T60	
	4025	H3, H4, H5, H6, H7, H8, H10, H12, H14	
	2779-55G		
	2571-45		
	2792		
	2452-05F		
	2221-02		
	2221-04		
	2141		



37 PC.

9-7540MR Tray category #4 (375 x 265mm)

Contents		3.50	1 / 5
	2335M	4, 4.5, 5, 5.5, 6, 7, 8, 9, 10, 11, 12, 13	
	2375M	E4, E5, E6, E7, E8	
	4375M	E10, E12, E14, E16, E18, E20	
	4435M	10, 11, 12, 13, 14, 17, 19, 21, 22, 24	
	2792		
	2755-55G		
	2571-45		
	2221-02		
	2221-04		
	2177DF		
	2452-05F		



40 PC.

9-93523MR Tray category #4 (375 x 265mm)

Contents		2.63	1 / 6
	3335M	6, 7, 8, 9, 10, 11, 12, 13, 14, 15, 16, 17, 19, 20, 21, 22	
	1120MR	H1.5, H2, H2.5, H3, H4, H5, H6, H8, H10	
	3792		
	3769-08F		
	3452-08F		
	3571-08		
	3221-03		
	3221-06		



31 PC.

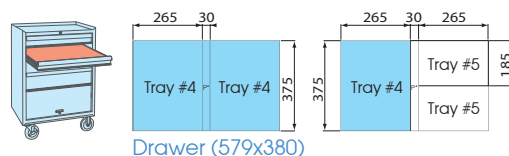
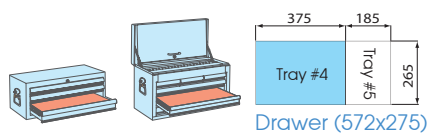

Tool Set Content

9-90131MR Tray category #4 (375 x 265mm)

Contents		3.1 kg	1 / 10
4033	T20, T25, T27, T30, T40, T45, T50, T55, T60		
4035	H4, H5, H6, H7, H8, H10, H12, H14, H17		
1120MR	H1.5, H2, H2.5, H3, H4, H5, H6, H8, H10		
1930	10 x 11, 12 x 14, 14 x 17		
3204 (Ø 60 ~ 140)			



31
PC.

9-1205MR Tray category #4 (375 x 265mm)

Contents		2.70 kg	1 / 6
1060	27, 28, 29, 30, 32		



5
PC.

9-1216MR 9-1216MR01 9-1216MR03 Tray category #4 (375 x 265mm)

KT NO.	Contents	3.20 kg	1 / 6
9-1216MR	1060	6, 8, 10, 12, 13, 14, 16, 17, 19, 21, 22, 24, 26, 27, 29, 32	
9-1216MR01	1060	6, 8, 10, 11, 13, 14, 16, 17, 18, 19, 21, 22, 24, 27, 30, 32	
9-1216MR03	1060	8, 10, 11, 12, 13, 14, 15, 17, 18, 19, 21, 22, 24, 27, 30, 32	



16
PC.

9-1219MR01 Tray category #4 (375 x 265mm)

Contents		2.25 kg	1 / 6
1060	6, 7, 8, 9, 10, 11, 12, 13, 14, 15, 16, 17, 18, 19, 20, 21, 22, 23, 24		



19
PC.

9-1218MR Tray category #4 (375 x 265mm)

Contents		2.12 kg	1 / 6
1060	6, 7, 8, 10, 11, 12, 13, 14, 15, 16, 17, 18, 19, 21, 22, 24		
1930	8 x 10, 9 x 11		



18
PC.

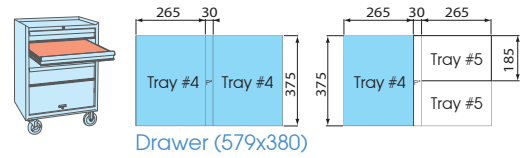
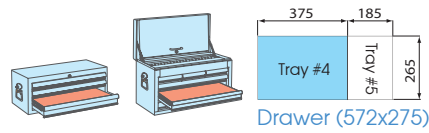

Tool Set Content

9-1282MR Tray category #4 (375 x 265mm)

Contents		kg	Box	Tray
	10D0	1.05	1	10
8, 9, 10, 11, 12, 13, 14, 15, 16, 17, 18, 19				



12 PC.

9-1272MR Tray category #4 (375 x 265mm)

Contents		kg	Box	Tray
	1067	1.45	1	5
6, 7, 8, 9, 10, 11, 12, 13, 14, 17, 19, 22				



12 PC.

9-1608MR Tray category #4 (375 x 265mm)

Contents		kg	Box	Tray
	1960	1.5	1	6
6 x 7, 8 x 9, 10 x 11, 12 x 13, 14 x 15, 16 x 17, 18 x 19, 20 x 22				



8 PC.

9-1609MR Tray category #4 (375 x 265mm)

Contents		kg	Box	Tray
	1960	1.93	1	6
8 x 9, 10 x 12, 11 x 13, 12 x 14, 14 x 17, 17 x 19, 19 x 21, 22 x 24, 23 x 26				



9 PC.

9-1709MR Tray category #4 (375 x 265mm)

Contents		kg	Box	Tray
	1970	2.18	1	6
8 x 9, 10 x 12, 11 x 13, 12 x 14, 14 x 17, 17 x 19, 19 x 21, 22 x 24, 23 x 26				



9 PC.

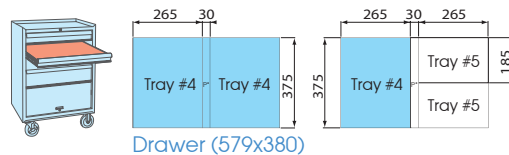
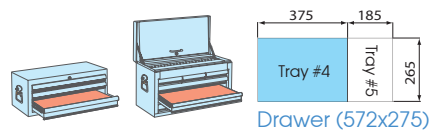

Tool Set Content



9-1711MR Tray category #4 (375 x 265mm)

Contents		2.80 kg	1 / 6
	1970	6 x 7, 8 x 9, 10 x 11, 12 x 13, 14 x 15, 16 x 17, 18 x 19, 20 x 22, 21 x 23, 24 x 27, 30 x 32	



11
PC.



9-90315MR Tray category #4 (375 x 265mm)

Contents		2.6 kg	1 / 6
	1900	8 x 10, 10 x 12, 12 x 14, 14 x 17, 17 x 19, 21 x 23, 22 x 24	
	1970	8 x 10, 10 x 12, 12 x 14, 14 x 17, 17 x 19, 21 x 23, 22 x 24	
	79093-05C		



15
PC.

9-1812MR

KT NO.	Contents	3.69 kg	1 / 6
9-1812MR	 1080	8, 10, 11, 12, 13, 14, 16, 17, 18, 19, 22, 24	
9-1912MR	 1081		

9-1912MR Tray category #4 (375 x 265mm)

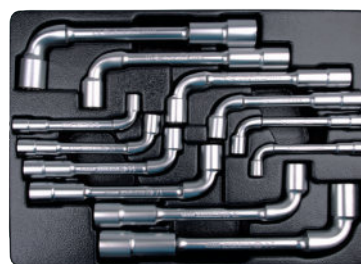

12
PC.

9-1838MR Tray category #4 (375 x 265mm)

Contents		2.57 kg	1 / 6
	1084	8, 10, 11, 12, 13, 15, 17, 19	

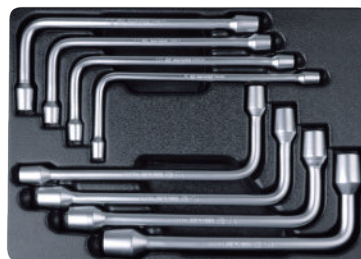

8
PC.

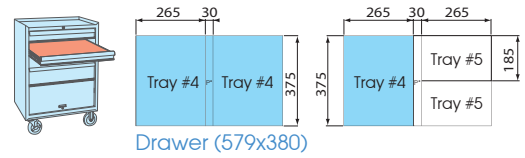
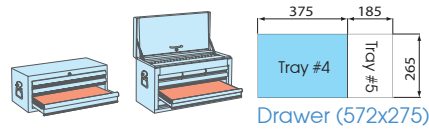

Tool Set Content

9-1C08MR Tray category #4 (375 x 265mm)

Contents		0.91 1 / 10
19C0	6 x 7, 8 x 9, 10 x 11, 12 x 13, 14 x 15, 16 x 17, 18 x 19, 20 x 22	



8
PC.

9-10115MR

KT NO.	Contents	1.9 1 / 10
9-10115MR	3731M	8, 9, 10, 11, 12, 13, 14, 15, 16, 17, 19, 22
9-102A15MR	373AM	
		373202R
		373203R
		373204R

9-102A15MR Tray category #4 (375 x 265mm)



15
PC.

9-12120MR Tray category #4 (375 x 265mm)

Contents		1.27 1 / 6
3731M	8, 10, 12, 13, 14, 15, 17, 19	
373204R		373203R



10
PC.

9-90109MN Tray category #4 (375 x 265mm)

Contents		2.28 1 / 6
1970	8 x 10, 10 x 12, 11 x 13, 12 x 14, 14 x 17, 17 x 19	
6011-10N	3611-12R	



8
PC.

9-91120MR Tray category #4 (375 x 265mm)

Contents		2.40 1 / 6
1120MR	H1.5, H2, H2.5, H3, H4, H5, H6, H8, H10	
1930	8 x 10, 10 x 12, 11 x 13, 14 x 17	
3731M	8, 10, 12, 13, 14	
6011-10N	3611-12R	



20
PC.

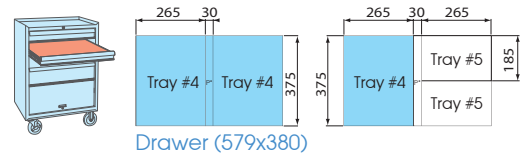
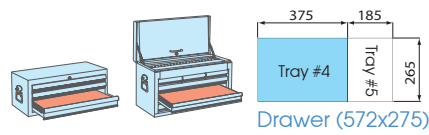

Tool Set Content

9-40207GP

9-40207GP01 Tray category #4 (375 x 265mm)



9-40207GP



9-40207GP01

7
PC.

KT NO.	Contents	kg	Box
9-40207GP	6111-08 6211-06 6311-06 68HS-07 68HB-07 68SS-07 68SB-07	1.5	1 / 10
9-40207GP01	6463-08C 6211-06 6311-06 67HS-07 67HB-07 67SS-07 67SB-07		

9-40604GP

Tray category #4 (375 x 265mm)

Contents

kg 1.98 Box 1 / 6



4
PC.

9-42144GP

Tray category #4 (375 x 265mm)

Contents

kg 1.63 Box 1 / 8

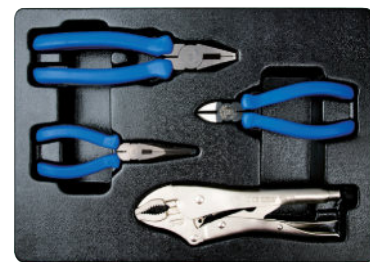

4
PC.

9-90205GN

9-90205GN01 Tray category #4 (375 x 265mm)



9-90205GN



9-90205GN01

5
PC.

Contents	kg	Box
9-90205GN 6313-06 6011-10N 6111-07 6463-08C 74410	1.98	1 / 6
9-90205GN01 6311-06		

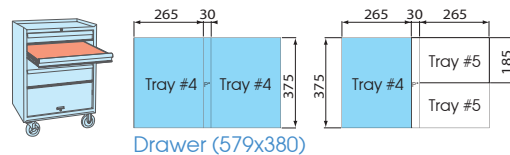
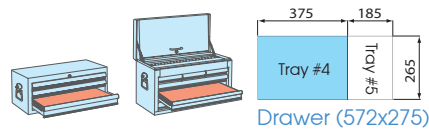

Tool Set Content

9-90103PP **9-90103PP01** **9-90103PP02** Tray category #4 (375 x 265mm)



9-90103PP



9-90103PP01



9-90103PP02

3 PC.

KT NO.	Contents	kg	1/5
9-90103PP			
9-90103PP01	3611-12P 6511-10	2.30	1 / 5
9-90103PP02		2.51	1 / 10

9-90103RR Tray category #4 (375 x 265mm)

Contents 2.3 1 / 5



3 PC.

9-90106SR Tray category #4 (375 x 265mm)

Contents 2.05 1 / 4



6 PC.

9-22108MR Tray category #4 (375 x 265mm)

Contents 1.10 1 / 10

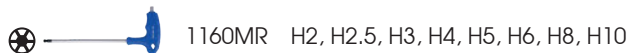

8 PC.

9-22308TR Tray category #4 (375 x 265mm)

Contents 1.10 1 / 10

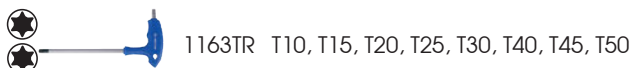

8 PC.



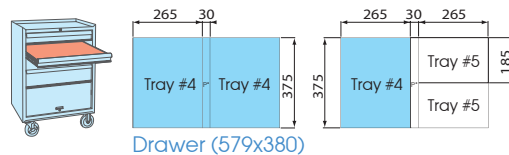
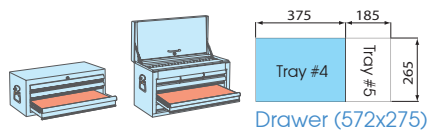

Tool Set Content

9-30110CR Tray category #4 (375 x 265mm)

Contents		1.4 kg	1 / 6 boxes
	1450 6, 7, 8, 9, 10, 11, 12, 13		
	5450 1/4, 5/16		



10
PC.

9-31110MR Tray category #4 (375 x 265mm)

Contents		1.0 kg	1 / 10 boxes
	1421 PH1 x 80, PH2 x 38, PH2 x 100, PH3 x 150		
	1422 3 x 75, 4 x 100, 5.5 x 125, 6.5 x 38, 6.5 x 150, 8 x 175		



10
PC.

9-31909PR Tray category #4 (375 x 265mm)

Contents		0.65 kg	1 / 6 boxes
	1427 T8H x 75, T9H x 75, T10H x 75, T15H x 75, T20H x 100, T25H x 100, T27H x 100, T30H x 125, T40H x 150		

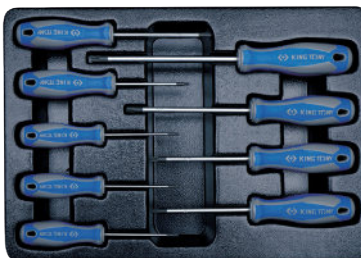

9
PC.

9-90310MR Tray category #4 (375 x 265mm)

Contents		1.08 kg	1 / 6 boxes
	1411 PH1 x 100, PH2 x 100, PH3 x 150		
	1412 5.5 x 100, 6.5 x 100, 8.0 x 150		
	76220-07		
	9CJ2120		
	14324003		
	24110214		

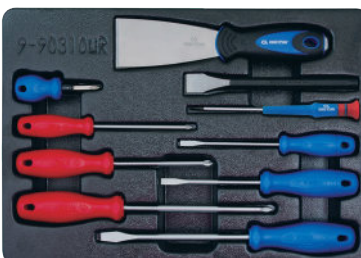

10
PC.

9-34128FR Tray category #4 (375 x 265mm)

Contents		1.98 kg	1 / 6 boxes
	1836P PH2, PH3		
	1836S 9, 11		
	1880P PH2, PH3		
	1880S 8, 10		
	1930 8 x 10, 11 x 13, 12 x 14		
	4112		
	414810S		
	3204		



14
PC.

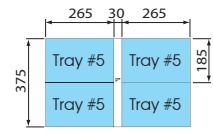
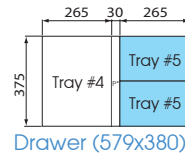

Tool Set Content

9-2526MR Tray category #5 (265 x 185mm)

Contents		0.90 kg	1 / 10
2335M	4, 4.5, 5, 5.5, 6, 7, 8, 9, 10, 11, 13		
2235M	4, 5, 5.5, 6, 7, 8, 9, 10, 11, 13		
2779-55G	2813		
2221-02			
2221-04	2792		



26
PC.

9-4119PR Tray category #5 (265 x 185mm)

Contents		1.10 kg	1 / 10
4033	T20, T25, T27, T30, T40, T45, T50, T55, T60		



9
PC.

9-4120PR Tray category #5 (265 x 185mm)

Contents		1.30 kg	1 / 10
4035	H4, H5, H6, H7, H8, H10, H12, H14, H17		



9
PC.

9-91026PR Tray category #5 (265 x 185mm)

Contents		1.30 kg	1 / 10
1143R	T10, T15, T20, T25, T27, T30, T40, T45, T50		
1147R	T10H, T15H, T20H, T25H, T27H, T30H, T40H		
4023	T30, T40, T45, T50, T55		
4375M	E10, E12, E14, E16, E18		



26
PC.

9-1303MR Tray category #5 (265 x 185mm)

Contents		0.50 kg	1 / 10
1930	10 x 11, 12 x 14, 14 x 17		

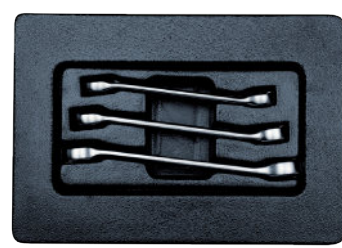

3
PC.

9-1905MR Tray category #5 (265 x 185mm)

Contents		0.82 kg	1 / 10
1950	10 x 12, 11 x 13, 14 x 17, 16 x 18, 19 x 22		



5
PC.

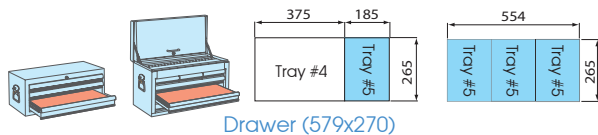

Drawer (579x270)

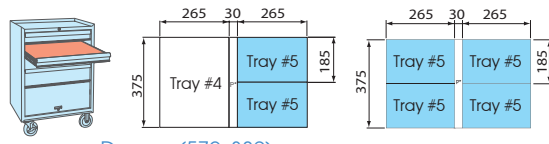

Drawer (579x380)

Tool Set Content

9-10112MR

KT NO.	Contents	kg	1.22	1 / 10
9-10112MR	3731M 10, 11, 12, 13, 14, 15, 16, 17, 19			373202R 373203R 373204R
9-102A12MR	373AM			

9-102A12MR Tray category #5 (265 x 185mm)



12 PC.

9-40103GP

Tray category #5 (265 x 185mm)

Contents	kg	0.83	1 / 10
6111-07	6211-06		
6311-06			



3 PC.

9-31106MR

Tray category #5 (265 x 185mm)

Contents	kg	0.60	1 / 10
1421 PH0 x 60, PH1 x 80, PH2 x 100			
1422 3 x 75, 5.5 x 100, 6.5 x 150			



6 PC.

9-4128FR

Tray category #5 (265 x 185mm)

Contents	kg	1.70	1 / 10
1836P PH2, PH3			
1836S 9, 11			
1880P PH2, PH3			
1880S 8, 10			
4112 414810S			



10 PC.

9-20110MR

Tray category #5 (265 x 185mm)

Contents	kg	1.10	1 / 10
1120MR H1.5, H2, H2.5, H3, H4, H5, H6, H8, H10			
3204 (Ø 60 ~ 140)			



10 PC.



Tool Set Content

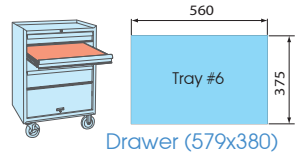

Drawer (579x380)

9-7576MR Tray category #6 (560 x 375mm)

Contents 7.69 1 / 3

3335M	8, 10, 11, 12, 13, 14, 15, 16, 17, 19, 20, 21, 22, 24	
3235M	8, 10, 11, 12, 13, 14, 15, 16, 17, 19, 21, 22, 24	
4335MR	10, 11, 12, 13, 14, 15, 16, 17, 18, 19, 20, 21, 22, 23, 24, 27, 30, 32	
4235M	10, 12, 13, 14, 17, 19, 21, 22, 24	
9TD403	12, 13, 14, 17, 19	
321510M	366516	3792
321512M	366521	
3452-08F	3769-08P	4311-16F
4768-10P	4452-18FR	4573-10



76 PC.

Contents

4251-03R	3221-03
4251-05R	3221-06
4251-10R	3221-10

9-94435MP Tray category #6 (560 x 375mm)

Contents 6.49 1 / 3

4435M	10, 11, 12, 13, 14, 15, 16, 17, 18, 19, 21, 24, 26, 29, 32	
4535M	10, 12, 13, 14, 17, 19, 21, 24	
4415M	17, 19, 21, 22	
4797P	68SS-07	68HS-07
6011-10R	6211-06	6311-08
6463-08C	74030	



35 PC.

9-31919MR Tray category #6 (560 x 375mm)

Contents 2.67 1 / 5

1411	PH0 x 75, PH2 x 38
1412	3 x 75, 6.5 x 38
1421	PH2 x 300
1422	6.5 x 300
1481	PH2 x 100, PH3 x 150
1482	6.5 x 100, 8 x 150
1427	T8H x 75, T10H x 75, T15H x 75, T20H x 100, T25H x 100, T27H x 100, T30H x 125
43280212	2121-18



19 PC.

9-90408TQ Tray category #6 (560 x 375mm)

Contents 2.06 1 / 5

75102-08G	75202-08G
75302-08G	75402-08G
75502-08G	79063-12
79093-05C	7911-12



8 PC.



Tool Set Content

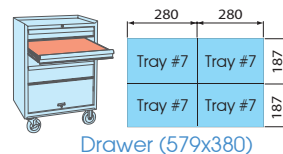

9-4057MR

Tray category #7 (280 x 187mm)

Contents

2.99 / 1 / 4

- 4330MR 8, 9, 10, 11, 12, 13, 14, 15, 16, 17, 18, 19, 20, 21, 22, 23, 24, 25, 26, 27, 28, 29, 30, 32, 33, 34, 36

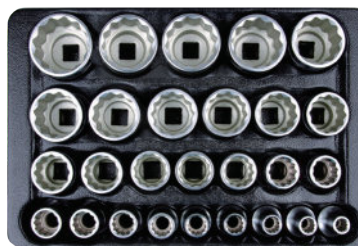

27 PC.

9-4557MR

Tray category #7 (280 x 187mm)

Contents

2.99 / 1 / 4

- 4335MR 8, 9, 10, 11, 12, 13, 14, 15, 16, 17, 18, 19, 20, 21, 22, 23, 24, 25, 26, 27, 28, 29, 30, 32, 33, 34, 36



27 PC.

9-4138PR

Tray category #7 (280 x 187mm)

Contents

1.9 / 1 / 10

- 4033 T20, T25, T27, T30, T40, T45, T50, T55, T60
- 4035 H4, H5, H6, H7, H8, H10, H12, H14, H17



18 PC.

9-7128PR

Tray category #7 (280 x 187mm)

Contents

1.20 / 1 / 10

- 3025 H3, H4, H5, H6, H7, H8, H10, H12
- 3023 T15, T20, T25, T27, T30, T40, T45, T50
- 3375M E8, E10, E12, E14, E16, E18
- 4375M E10, E12, E14, E16, E18, E20



28 PC.

9-4427MP

Tray category #7 (280 x 187mm)

Contents

4.09 / 1 / 4

- 4535M 8, 9, 10, 11, 12, 13, 14, 15, 16, 17, 18, 19, 20, 21, 22, 23, 24, 25, 26, 27, 28, 29, 30, 32, 33, 34, 36



27 PC.

9-4827MP

Tray category #7 (280 x 187mm)

Contents

4.09 / 1 / 4

- 4530M 8, 9, 10, 11, 12, 13, 14, 15, 16, 17, 18, 19, 20, 21, 22, 23, 24, 25, 26, 27, 28, 29, 30, 32, 33, 34, 36

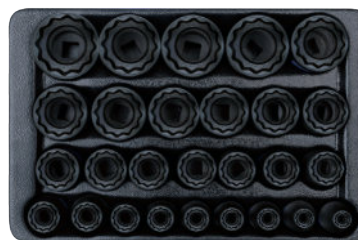

27 PC.

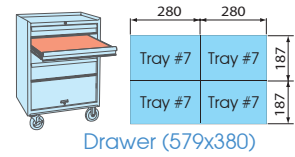

Tool Set Content

9-12C7MR Tray category #7 (280 x 187mm)

Contents		0.78	1 / 10
	1061	8, 10, 11, 13, 14, 17, 19	



7 PC.

9-3612MR Tray category #7 (280 x 187mm)

Contents		1.27	1 / 10
	3351MR	8, 9, 10, 11, 12, 13, 14, 15, 16, 17, 18, 19	



12 PC.

9-30904AY Tray category #7 (280 x 187mm)

- Use for scribing, aligning, installing and removing O rings, seals and washers stainless

Contents		0.43	1 / 10
	43250115Y		43270115Y
	43260115Y		43290115Y



4 PC.

Tool Set Content

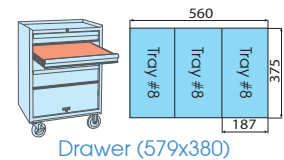

9-30909AY Tray category #8 (375 x 187mm)

Contents		0.69	1 / 12
	43250115Y		43350175Y
	43260115Y		43360175Y
	43270115Y		43370175Y
	43290115Y		43390175Y
	43240115Y		



9 PC.

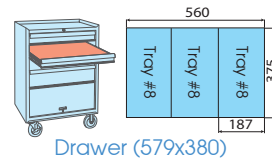

Tool Set Content

9-12110MR Tray category #8 (375 x 187mm)

Contents	1.89	/ 1 / 12
3731M	8, 10, 12, 13, 14, 17, 19, 21, 22, 24	



10
PC.

9-90114MR Tray category #8 (375 x 187mm)

Contents	1.75	/ 1 / 12
1930	8 x 10, 10 x 11, 12 x 14, 14 x 17, 17 x 19	
1060	8, 10, 12, 14, 17, 19, 21, 22, 24	



14
PC.

9-40618GP Tray category #8 (375 x 187mm)

Contents	1.89	/ 1 / 12
1471	PH1 x 100, PH2 x 100	
1472	4 x 100, 5.5 x 125	
6CB02	100~500V	
6318-08A	6116-07A	6216-06A



8
PC.

9-1011GP Tray category #8 (375 x 187mm)

Contents	1.15	/ 1 / 12
761G	ø6x185mm	
763G	ø4x185mm, ø5x185mm, ø6x185mm, ø8x185mm	
764G	ø2x140mm, ø3x150mm, ø4x180mm, ø5x200mm, ø6x210mm, ø8x220mm	



11
PC.

9-91016MR Tray category #8 (375 x 187mm)

Contents	1.15	/ 1 / 12
3730M	8, 10, 12, 13, 14, 17, 19	
1123R	T10, T15, T20, T25, T27, T30, T40, T45, T50	



16
PC.

Tool Set Content

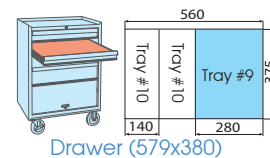

9-4335MR

KT NO.	Contents	5.01 kg	1/2
9-4335MR	4235M	8, 9, 10, 11, 12, 13, 14, 15, 16, 17, 18, 19, 20, 21, 22, 23, 24, 25, 26, 27, 28, 29, 30, 32, 36	
9-4235MR	4230M		

9-4235MR Tray category #9 (375 x 280mm)



25 PC.

9-4435MP Tray category #9 (375 x 280mm)

Contents	7.3 kg	1/2
4435M	8, 9, 10, 11, 12, 13, 14, 15, 16, 17, 18, 19, 20, 21, 22, 23, 24, 25, 26, 27, 28, 29, 30, 32, 36	



25 PC.

9-6414MP 9-6414SP Tray category #9 (375 x 280mm)



9-6414MP



9-6414SP

14 PC.

KT NO.	Contents	10.9 kg	1/2
9-6414MP	6435M	19, 21, 22, 24, 26, 27, 29, 30, 32, 33, 35, 36, 38, 41	
9-6414SP	6435S		

9-12A1MR Tray category #9 (375 x 280mm)

Contents	1.91 kg	1/4
1061	8, 10, 12, 13, 14, 16, 17, 18, 19, 22, 24	



11 PC.



Tool Chest Set Content

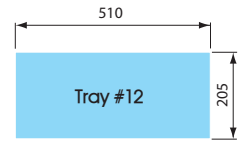
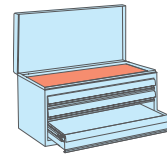

Drawer (504 x 195 mm)

9-4338MR

9-4338MR01

9-4338MR03

Tray category #12 (510 x 205mm)

▪ For Top drawer of 87401-2 / 87401-3 / 87401-3H P.51



9-4338MR



9-4338MR01 / 9-4338MR03

38
PC.

KT NO.	Contents	5.96 kg / 1 / 5		
9-4338MR		4768-10F	PH2, PH3 4021	4251-05R 4251-10R
9-4338MR01	10, 11, 12, 13, 14, 15, 16, 17, 18, 19, 20, 21, 22, 23, 24, 27, 30, 32	4755-10G	8, 10 4022	4572-12
9-4338MR03	8, 10, 11, 12, 13, 14, 15, 16, 17, 18, 19, 20, 21, 22, 24, 27, 30, 32	4755-10G	T25, T27, T30, T40 4023	4791R
			H4, H5, H6, H8, H10, H12 4025	463521RC

▪ for 87401-2 / 87401-3 / 87401-3H P.51

Tool Chest Set Content

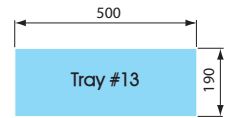
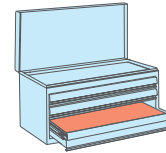

Drawer (504 x 195 mm)

9-90121MR

Tray category #13 (500 x 190mm)

Contents	2.1 kg / 1 / 5	
1900	6 x 7, 8 x 10, 11 x 13, 12 x 13, 17 x 19, 22 x 24	
1970	8 x 9, 10 x 11, 12 x 13, 14 x 15, 16 x 17, 18 x 19	
1120MR	H1.5, H2, H2.5, H3, H4, H5, H6, H8, H10	



21
PC.

9-90126MR

Tray category #13 (500 x 190mm)

Contents	2.38 kg / 1 / 5	
1060	6, 7, 8, 9, 10, 11, 12, 13, 14, 15, 16, 17, 18, 19, 20, 21, 22	
1120MR	H1.5, H2, H2.5, H3, H4, H5, H6, H8, H10	



26
PC.

9-90104GP

Tray category #13 (500 x 190mm)

Contents	1.36 kg / 1 / 5	
3611-08P	6511-10	
6111-07	6311-06	



4
PC.

▪ for 87401-2 / 87401-3 / 87401-3H P.51

Tool Chest Set Content

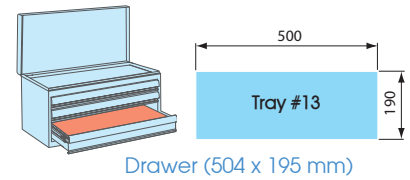

9-31006MR

Tray category #13 (500 x 190mm)

Contents

0.74 kg 1 / 5

⊕ 1421 PH1 x 80, PH2 x 38, PH3 x 150

⊖ 1422 6.5 x 38, 5.5 x 100, 8 x 175

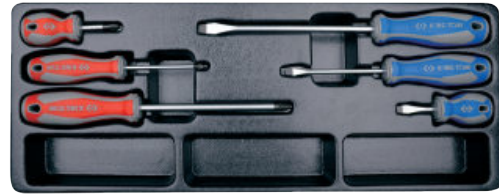

6 PC.

9-90113MA

Tray category #13 (500 x 190mm)

Contents

2.98 kg 1 / 5

4023 T45

4025 H8, H12

402B M16

3204 401408M 9AE42

112005MR 9AE2-6606 9AE2-7614
112006MR 9AE2-7608 9AE2-9315



13 PC.

▪ For 87402 / 87A05 P.52

Tool Box Set Content

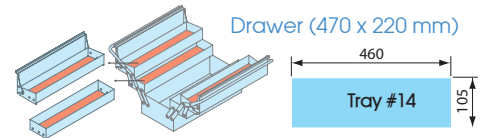

9-4219MR

9-4219MR07

9-4219SR08

9-4319MR

9-4319MR01

9-4319MR02

9-4319MR05

Tray category #14 (460 x 105mm)



9-4219MR



9-4219MR07



9-4219SR08



9-4319MR/9-4319MR05



9-4319MR02



9-4319MR01

20 PC.

KT NO.

Contents

2.5 kg 1 / 8

KT NO.	Contents	
9-4219MR	4768-10F	4330MR 10, 11, 12, 13, 14, 15, 16, 17, 18, 19, 20, 21, 22, 23, 24, 27, 30, 32
9-4219MR07	4762-10F	4330MR 10, 11, 12, 13, 14, 15, 16, 17, 18, 19, 20, 21, 22, 23, 24, 25, 26, 27
9-4219SR08	4762-10F	4330SR 5/16, 3/8, 7/16, 15/32, 1/2, 9/16, 19/32, 5/8, 11/16, 3/4, 25/32, 13/16, 7/8, 15/16, 1, 1-1/16, 1-3/16, 1-1/4
9-4319MR	4768-10F	4335MR 10, 11, 12, 13, 14, 15, 16, 17, 18, 19, 20, 21, 22, 23, 24, 27, 30, 32
9-4319MR01	4755-10G	
9-4319MR02	4779-10FR	
9-4319MR05	4768-10F	

4791R



▪ For 87402 / 87A05 P.52

Tool Box Set Content

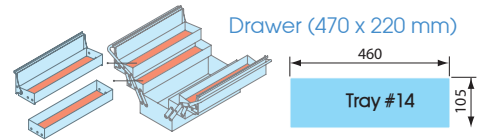

9-4116FR

9-4116FR03 Tray category #14 (460 x 105mm)



6 PC.

KT NO.	Contents	kg	1/8
9-4116FR	463521RC 4251-05R 4251-10R 4572-12	2.2	1/8
9-4116FR03	463021RC 4452-18FR 4223-02R		

9-1606MR

9-1606MR01 Tray category #14 (460 x 105mm)



6 PC.

KT NO.	Contents	kg	1/8
9-1606MR	10 x 12, 12 x 14, 14 x 17, 17 x 19, 19 x 21, 23 x 26	1.1	1/8
9-1606MR01	1960 8 x 10, 10 x 12, 12 x 14, 14 x 17, 17 x 19, 22 x 24		

9-1217MR

9-1217MR Tray category #14 (460 x 105mm)



7 PC.

Contents	kg	1/8
1060 17, 18, 19, 20, 21, 22, 24	1.5	1/8

9-1716MR

9-1716MR Tray category #14 (460 x 105mm)



6 PC.

Contents	kg	1/8
1970 8 x 9, 10 x 11, 12 x 13, 14 x 15, 16 x 17, 18 x 19	1.1	1/8

9-90115MR

9-90115MR Tray category #14 (460 x 105mm)



15 PC.

Contents	kg	1/8
1900 6 x 7, 8 x 10, 11 x 13, 12 x 13, 17 x 19, 22 x 24	1.2	1/8
1120MR H1.5, H2, H2.5, H3, H4, H5, H6, H8, H10		

9-40203GP

9-40203GP Tray category #14 (460 x 105mm)



3 PC.

Contents	kg	1/8
6111-07 6211-06	0.8	1/8
6311-06		

9-90120MR

9-90120MR Tray category #14 (460 x 105mm)



20 PC.

Contents	kg	1/8
1060 6, 7, 8, 9, 10, 11, 12, 13, 14, 15, 16	1.5	1/8
1120MR H1.5, H2, H2.5, H3, H4, H5, H6, H8, H10		

9-30106MR

9-30106MR Tray category #14 (460 x 105mm)



6 PC.

Contents	kg	1/8
1421 PH1 x 80, PH2 x 100, PH3 x 150	0.8	1/8
1422 5.5 x 100, 6.5 x 150, 8 x 175		

9-90125MR

9-90125MR Tray category #14 (460 x 105mm)



15 PC.

Contents	kg	1/8
1900 8 x 10, 10 x 12, 12 x 14, 14 x 17, 17 x 19, 22 x 24	1.2	1/8
1120MR H1.5, H2, H2.5, H3, H4, H5, H6, H8, H10		

9-30206MR

9-30206MR Tray category #14 (460 x 105mm)



6 PC.

Contents	kg	1/8
1461 PH1 x 75, PH2 x 100, PH3 x 150	1.18	1/8
1462 5.5 x 100, 6.5 x 150, 8 x 175		

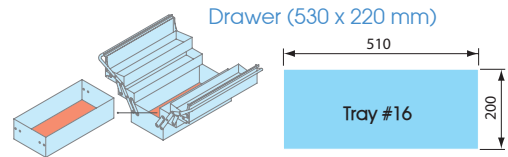
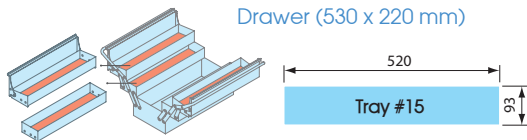

▪ For 87408 only P.52

Tool Box Set Content

9-4029CR Tray category #15 (520 x 93mm)

29 PC.



Contents		kg 2.67	1 / 5
● 4025	H5, H6, H8, H10, H12, H14		
○ 4330MR	8, 10, 11, 12, 13, 14, 15, 16, 17, 19, 21, 22, 23, 24, 26, 27, 28, 30, 32		
○ 4330SR	7/16, 9/16, 7/8		
○ 463521RC			

9-6010MR Tray category #16 (510 x 200mm)

9-6010MR01

10 PC.



KT NO.	Contents		kg	1 / 2
9-6010MR	● 6330M	33, 36, 38, 41, 46, 50	9.70	1 / 2
9-6010MR01		30, 32, 36, 41, 46, 50	9.50	

9-4156PR Tray category #15 (520 x 93mm)

6 PC.



Contents		kg 1.99	1 / 5
● 4779-10GR	● 4572-12		
● 4251-03R	● 4791R		
● 4251-05R			
● 4251-10R			

9-1215MR03 Tray category #16 (510 x 200mm)

15 PC.



Contents		kg 3.12	1 / 2
● 1060	8, 10, 11, 12, 13, 14, 17, 18, 19, 21, 22, 24, 27, 30, 32		

9-90111MR Tray category #15 (520 x 93mm)

11 PC.



Contents		kg 1.25	1 / 5
● 1145MR	H1.5, H2, H2.5, H3, H4, H5, H6, H8, H10		
● 3611-10P	● 6511-10C		



HAND SOCKETS & ACCESSORIES



Socket Made



Precision forging Technology

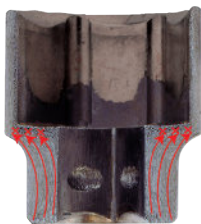

Other brand (not good)



King Tony brand (good)

In forging process, metal moved while it is still in the solid state. King Tony specialized in forging technology to create better metal configuration. Non-straight grain flow and non-sharp corners can extend lifetime and durability of socket. Torque is transmitted for powerful tightening under safety.

Conventional heat treatment and microstructural

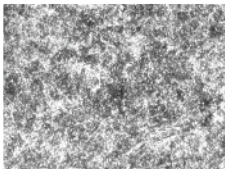

Other brand: Over of Troostite (Zn,Mn) element will bring weak point. (not good)

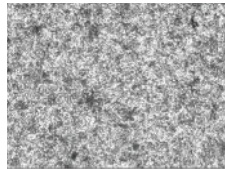

King Tony brand: Well spread (Fe) element will bring better strength. (good)

Heat treatment involves the use of heating or chilling experience and time control. King Tony controls heat treatment system to ensure the right hardness without the brittleness. From microstructural picture you can see elements are well-distributed.

Professional production & quality control



KING TONY hand socket reach 30% higher than DIN international standard.

Quality control also ensure that a sufficient level of production output. King Tony uses advance technology to inspect tiny difference on each step. Our hand socket, ratchet, extension bar, and power handle is 30% higher than international DIN standards. Impact socket reach 50% higher torque than DIN standards.

Finest material for tools

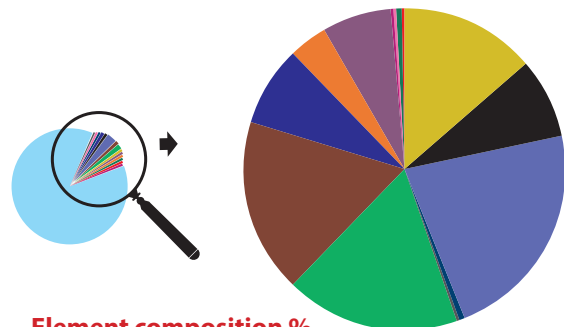

Element composition %

• Fe 97.1025%	• Mo 0.2325%	• P 0.0125%
• Mn 0.6485%	• Si 0.2301%	• S 0.0104%
• Ni 0.5089%	• Cu 0.1970%	• Co 0.0092%
• Cr 0.5058%	• V 0.1130%	• W 0.0088%
• C 0.4000%	• Al 0.0196%	• B 0.0012%

Tools are made to extend hand work. King Tony selects different material depends on its difference of nature for tightening, power impacting, cutting, rotating, and locking. Choose qualified material to meet required lifetime for professional use and consumption.

Extremely hard-wearing performance

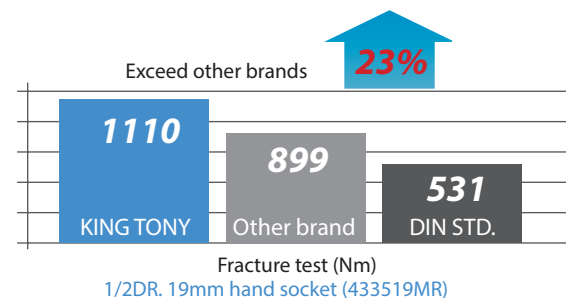
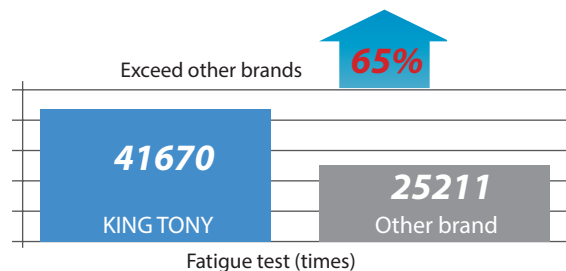

King Tony offers reliable tools for professional users, strictly controls its quality to ensure achievement of required performance. From "fracture & fatigue test", you will know the difference we have when compare to others.

Standard Socket

KT No. & D1



2330M

- Metric-DIN 3124, ISO 2725-1
- Inch-ANSI/ASME B107.1

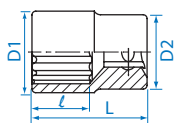

2330S 1/4"



KT NO.	mm	D1 mm	D2 mm	l mm	L mm	⚖️	📦
233004M	4	6.8	11.8	4	24	9	20 / 600
233045M	4.5	7.4	11.8	5	24	9	20 / 600
233005M	5	8.0	11.8	6	24	9	20 / 600
233055M	5.5	8.7	11.8	6	24	11	20 / 600
233006M	6	9.2	11.8	7	24	11	20 / 600
233007M	7	10.3	11.8	7	24	10	20 / 600
233008M	8	11.4	11.8	8	24	12	20 / 600
233009M	9	12.8	12.0	8	24	12	20 / 600
233010M	10	14.3	13.0	9	24	13	12 / 360
233011M	11	15.8	14.2	9	24	18	12 / 360
233012M	12	16.8	15.5	9	24	21	12 / 360
233013M	13	17.8	16.5	9	24	23	12 / 360
233014M	14	19.6	18.5	9	24	31	10 / 360

KT NO.	inch	D1 mm	D2 mm	l mm	L mm	⚖️	📦
233005S	5/32	6.8	11.8	4	24	9	20 / 600
233006S	3/16	7.9	11.8	6	24	9	20 / 600
233007S	7/32	8.7	11.8	6	24	10	20 / 600
233008S	1/4	9.5	11.8	7	24	10	20 / 600
233009S	9/32	10.3	11.8	7	24	10	20 / 600
233010S	5/16	11.4	11.8	8	24	10	20 / 600
233011S	11/32	13.7	12.2	8	24	12	20 / 600
233012S	3/8	14.2	13.0	8	24	14	12 / 360
233014S	7/16	15.8	14.2	9	24	18	12 / 360
233015S	15/32	16.8	15.5	9	24	21	12 / 360
233016S	1/2	17.6	16.5	9	24	24	12 / 360

2335M

- Metric-DIN 3124, ISO 2725-1
- Inch-ANSI/ASME B107.1

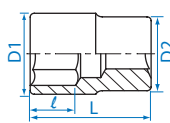

2335S 1/4"



KT NO.	mm	D1 mm	D2 mm	l mm	L mm	⚖️	📦
233532M	3.2	5.7	11.8	3.5	24	9	20 / 600
233504M	4	6.8	11.8	4	24	9	20 / 600
233545M	4.5	7.4	11.8	5	24	10	20 / 600
233505M	5	8.0	11.8	6	24	10	20 / 600
233555M	5.5	8.7	11.8	6	24	10	20 / 600
233506M	6	9.2	11.8	7	24	10	20 / 600
233507M	7	10.3	11.8	7	24	11	20 / 600
233508M	8	11.4	11.8	8	24	11	20 / 600
233509M	9	12.8	12.0	8	24	13	20 / 600
233510M	10	14.3	13.0	9	24	14	12 / 360
233511M	11	15.8	14.2	9	24	19	12 / 360
233512M	12	16.8	15.5	9	24	22	12 / 360
233513M	13	17.8	16.5	9	24	25	12 / 360
233514M	14	19.6	18.5	9	24	32	10 / 300
233515M	15	20.9	19.3	12	24	39	10 / 300

KT NO.	inch	D1 mm	D2 mm	l mm	L mm	⚖️	📦
233505S	5/32	6.8	11.8	4	24	9	20 / 600
233506S	3/16	7.9	11.8	6	24	11	20 / 600
233507S	7/32	8.7	11.8	6	24	11	20 / 600
233508S	1/4	9.5	11.8	7	24	11	20 / 600
233509S	9/32	10.3	11.8	7	24	11	20 / 600
233510S	5/16	11.4	11.8	8	24	11	20 / 600
233511S	11/32	13.7	12.2	8	24	12	20 / 600
233512S	3/8	14.2	13.0	8	24	14	12 / 360
233514S	7/16	15.8	14.2	9	24	19	12 / 360
233515S	15/32	16.8	15.5	9	24	22	12 / 360
233516S	1/2	17.6	16.5	9	24	24	12 / 360
233518S	9/16	19.6	18.5	9	24	31	10 / 300

Deep Socket

2235M

- DIN 3124, ISO 2725-1

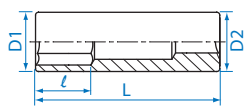

1/4"



KT NO.	mm	D1 mm	D2 mm	l mm	L mm	⚖️	📦
223504M	4	6.9	11.6	6	49.5	18	20 / 320
223545M	4.5	7.5	11.6	6	49.5	20	20 / 320
223505M	5	8.0	11.6	7	49.5	21	20 / 320
223555M	5.5	8.8	11.6	7	49.5	21	20 / 320
223506M	6	9.5	11.6	8	49.5	22	20 / 320
223507M	7	10.5	11.6	12	49.5	23	20 / 320
223508M	8	11.8	11.8	15	50	24	20 / 320
223509M	9	13.0	13.0	15	50	30	15 / 240
223510M	10	14.5	14.5	15	50	38	15 / 240
223511M	11	15.8	15.8	21	50	43	15 / 240
223512M	12	16.8	16.8	21	50	48	15 / 240
223513M	13	17.8	17.8	21	50	52	15 / 240
223514M	14	19.8	19.8	21	50	69	15 / 240
223515M	15	20.9	20.9	25	50	71	12 / 240

2235S

- Inch-ANSI/ASME B107.1

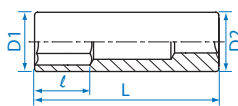

1/4"



KT NO.	inch	D1 mm	D2 mm	l mm	L mm	⚖️	📦
223505S	5/32	6.8	11.8	6	50	19	20 / 320
223506S	3/16	7.9	11.8	7	50	20	20 / 320
223507S	7/32	8.7	11.8	9	50	21	20 / 320
223508S	1/4	9.5	11.8	9	50	23	20 / 320
223509S	9/32	10.3	11.8	15	50	24	20 / 320
223510S	5/16	11.8	11.8	15	50	25	20 / 320
223511S	11/32	13.0	13.0	15	50	32	15 / 240
223512S	3/8	14.5	14.5	15	50	41	15 / 240
223514S	7/16	15.8	15.8	21	50	47	15 / 240
223516S	1/2	17.6	17.6	21	50	54	15 / 300
223518S	9/16	19.6	19.6	21	50	71	15 / 270



Deep Socket

2230M

1/4"

- DIN 3124, ISO 2725-1

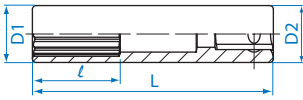

KT NO.	mm	D1 mm	D2 mm	l mm	L mm	⚖️	📦
223004M	4	6.8	11.8	6	50	20	20 / 320
223045M	4.5	7.4	11.8	7	50	20	20 / 320
223005M	5	8.0	11.8	7	50	20	20 / 320
223055M	5.5	8.7	11.8	9	50	20	20 / 320
223006M	6	9.2	11.8	9	50	21	20 / 320
223007M	7	10.3	11.8	15	50	22	20 / 320
223008M	8	11.8	11.8	15	50	25	20 / 320
223009M	9	13.0	13.0	15	50	28	15 / 240
223010M	10	14.5	14.5	15	50	36	15 / 240
223011M	11	15.8	15.8	21	50	41	15 / 240
223012M	12	16.8	16.8	21	50	47	15 / 240
223013M	13	17.8	17.8	21	50	49	15 / 240
223014M	14	19.8	19.8	21	50	66	15 / 240

Double Square Socket

2310M

2310S

1/4"

- Metric-DIN 3120
- Inch-ANSI / ASME B107.1

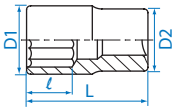

KT NO.	mm	D1 mm	D2 mm	l mm	L mm	⚖️	📦
231008M	8	13.8	13.0	9	24	16	12 / 360
231010M	10	16.8	15.4	9	24	22	12 / 360

KT NO.	inch	D1 mm	D2 mm	l mm	L mm	⚖️	📦
231010S	5/16	13.8	13.0	9	24	15	12 / 360
231012S	3/8	16.8	15.4	9	24	24	12 / 360

Star Socket

2375M

1/4"

- DIN 3120

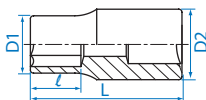

KT NO.	Size	D1 mm	D2 mm	l mm	L mm	⚖️	📦
237504M	E4	6.0	11.8	3.6	24	9	20 / 600
237505M	E5	7.0	11.8	4.0	24	10	20 / 600
237506M	E6	8.0	11.8	6.0	24	10	20 / 600
237507M	E7	8.5	11.8	7.0	24	11	20 / 600
237508M	E8	9.8	11.8	8.0	24	11	20 / 600
237510M	E10	11.8	11.8	9.0	24	13	20 / 600

Star Socket

2275M

1/4"

- DIN 3120

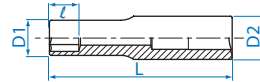

KT NO.	Size	D1 mm	D2 mm	l mm	L mm	⚖️	📦
227504M	E4	6.0	11.8	3.6	50	21	20 / 320
227505M	E5	7.0	11.8	4.0	50	22	20 / 320
227506M	E6	8.0	11.8	6.0	50	24	20 / 320
227507M	E7	8.5	11.8	7.0	50	24	20 / 320
227508M	E8	9.8	11.8	8.0	50	26	20 / 320

Bit Socket



In order to get normal life of bit socket, always use within limited torque to bit.

2011X

1/4"

- Phillips head
- DIN ISO 8764-1

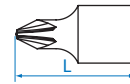

KT NO.	⊕ No.	L mm	⚖️	📦
201101X	PH1	25	9	20 / 600
201102X	PH2	25	9	20 / 600
201103X	PH3	25	10	20 / 600
201104X	PH4	25	12	20 / 600

2012X

1/4"

- Slotted head
- DIN ISO 2380-1

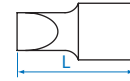

KT NO.	Tip width mm	Tip thickness mm	L mm	⚖️	📦
201235X	3.5	0.6	25	8	20 / 600
201255X	5.5	1.0	25	9	20 / 600
201208X	8	1.2	25	10	20 / 600

2015X

1/4"

- Hexagon head
- DIN ISO 2380-1

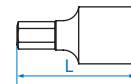

KT NO.	mm	L mm	⚖️	📦
201503MX	H3	25	8	20 / 600
201504MX	H4	25	9	20 / 600
201505MX	H5	25	10	20 / 600
201506MX	H6	25	10	20 / 600
201508MX	H8	25	13	20 / 600
201510MX	H10	25	15	20 / 600
201506SX	3/16	25	9	20 / 600
201508SX	1/4	25	10	20 / 600

Bit Socket

KT No. & D1



2013X

1/4"

- For torx internal screw

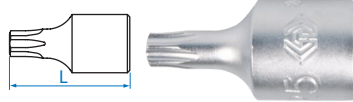

KT NO.	Size	L mm	Weight	Packaging
201308X	T8	25	8	20 / 600
201309X	T9	25	8	20 / 600
201310X	T10	25	8	20 / 600
201315X	T15	25	8	20 / 600
201320X	T20	25	9	20 / 600
201325X	T25	25	9	20 / 600
201327X	T27	25	9	20 / 600
201330X	T30	25	10	20 / 600
201340X	T40	25	11	20 / 600

2018X

1/4"

- Pozidriv head
- DIN ISO 8764-1



KT NO.	No.	L mm	Weight	Packaging
201801X	PZ1	25	9	20 / 600
201802X	PZ2	25	9	20 / 600
201803X	PZ3	25	10	20 / 600
201804X	PZ4	25	11	20 / 600

2031

1/4"

- Phillips head
- DIN ISO 8764-1



KT NO.	No.	L mm	Weight	Packaging
203101	PH1	37	15	20 / 600
203102	PH2	37	15	20 / 600
203103	PH3	37	15	20 / 600
203104	PH4	37	16	20 / 600

2032

1/4"

- Slotted head
- DIN ISO 8764-1



KT NO.	Tip width mm	Tip thickness mm	L mm	Weight	Packaging
203235	3.5	0.5	37	15	20 / 600
203204	4	0.8	37	14	20 / 600
203255	5.5	1.0	37	15	20 / 600
203265	6.5	1.2	37	15	20 / 600
203207	7	1.2	37	15	20 / 600
203208	8	1.2	37	16	20 / 600
203210	10	1.6	37	20	20 / 600

2035

2035S

1/4"

- Hexagon head
- DIN 7422 / 3120

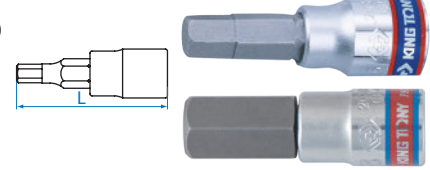

KT NO.	mm	L mm	Weight	Packaging
203503	H3	37	15	20 / 600
203504	H4	37	15	20 / 600
203505	H5	37	15	20 / 600
203506	H6	37	16	20 / 600
203507	H7	37	18	20 / 600
203508	H8	37	19	20 / 600
203510	H10	37	23	20 / 600

KT NO.	inch	L mm	Weight	Packaging
203504S	H1/8	37	15	20 / 600
203505S	H5/32	37	15	20 / 600
203506S	H3/16	37	16	20 / 600
203507S	H7/32	37	17	20 / 600
203508S	H1/4	37	18	20 / 600
203510S	H5/16	37	19	20 / 600
203512S	H3/8	37	22	20 / 600



Bit Socket

KT No. & D1



2033



- For torx internal screw
- DIN 3120



KT NO.	Size	L mm		
203308	T8	37	14	20 / 600
203309	T9	37	14	20 / 600
203310	T10	37	14	20 / 600
203315	T15	37	14	20 / 600
203320	T20	37	15	20 / 600
203325	T25	37	15	20 / 600
203327	T27	37	15	20 / 600
203330	T30	37	16	20 / 600
203340	T40	37	16	20 / 600

2037



- For tamper resistant torx screw
- DIN 3120



KT NO.	Size	L mm		
203708	T8H	37	14	20 / 600
203709	T9H	37	14	20 / 600
203710	T10H	37	14	20 / 600
203715	T15H	37	14	20 / 600
203720	T20H	37	15	20 / 600
203725	T25H	37	15	20 / 600
203727	T27H	37	15	20 / 600
203730	T30H	37	15	20 / 600
203740	T40H	37	16	20 / 600

2038



- Pozidriv head
- DIN 3120



KT NO.	No.	L mm		
203801	PZ1	37	15	20 / 600
203802	PZ2	37	15	20 / 600
203803	PZ3	37	15	20 / 600



90 Teeth Dustproof Ratchet **PAT.**



HAND SOCKET & ACCESSORIES



- Material
 - chrome vanadium alloy steel handle
 - chrome molybdenum steel (gear) driver
- Finishing
 - polished, chrome plated
 - black driver by phosphate sunk

2773-55GS

1/4"
IP 51
2 PC.
PAT.

- 1/4" DR. & 1/2" DR. 90 teeth reversible ratchet
- 90 teeth ratchet mechanism, allowing ratchet action in very tight spaces
- IP51, dustproof design

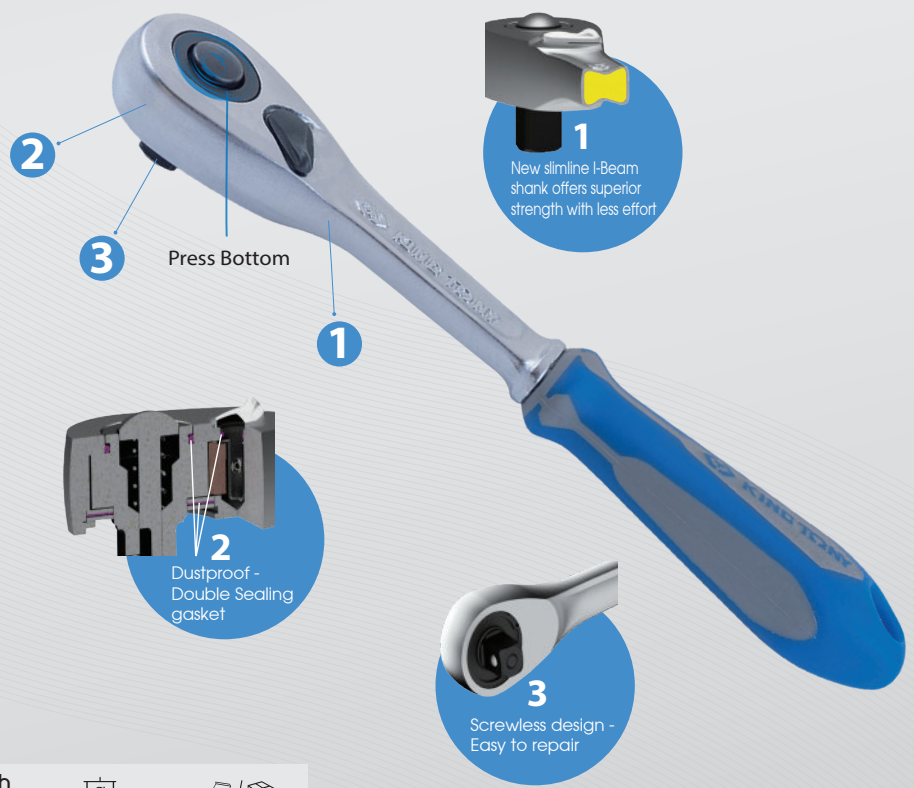

1
New slimline I-Beam shank offers superior strength with less effort

2
Dustproof - Double Sealing gasket

3
Screwless design - Easy to repair



KT NO.	Square DR.	Overall length			
		inch	mm		
2773-55GS	1/4"	5-1/2"	140	110	1 / 100
2773DK				renewal kits	

Mini Bit Ratchet **PAT.**



HAND SOCKET & ACCESSORIES

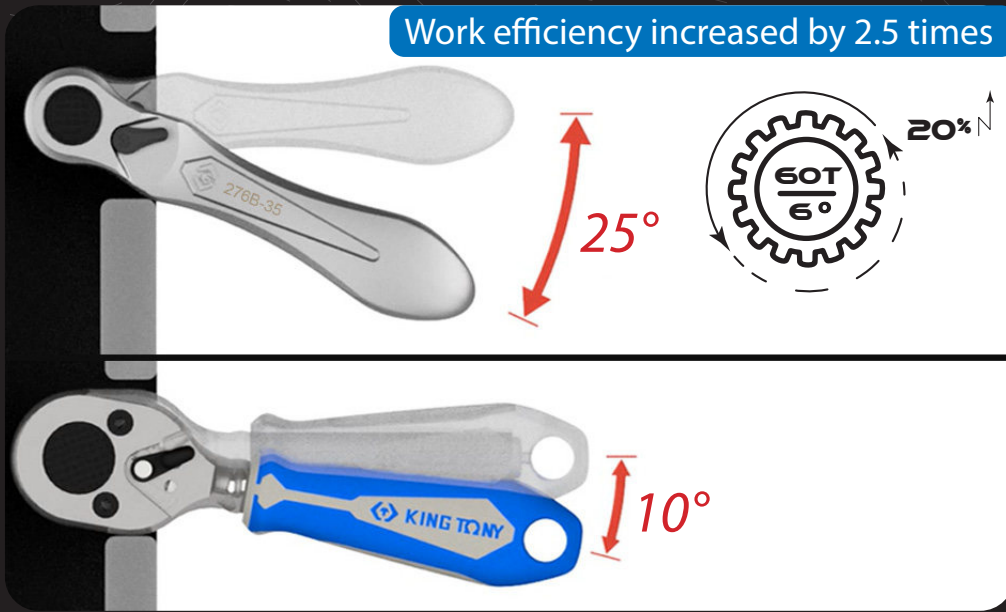

276B-0225

- Reversible ratchet
- 6° gear action degree (60 teeth)
- Quick release design, convenient for users to quickly replace bit
- BIT-holder 12-PT design for quick bit replacement
- Reduced head size and shape of waist can be used quickly and conveniently in narrow spaces



▪ Quick release Design

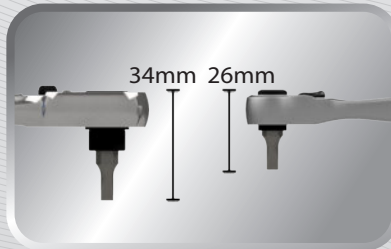

▪ Operating space 30% thinner

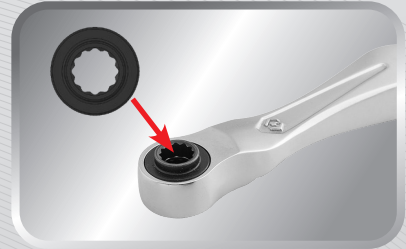

▪ D-head 12 PT design for quick bit replacement

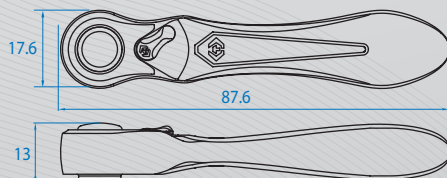

Contents

80 1 / 36

7702-25

276B-35

Ratchet

2725

FINE GEAR 1/4"

- Reversible ratchet
- 8° gear action degree (45 teeth)

KT NO.	Overall length			
	inch	mm		
2725-55F	5-1/2	140	156	5 / 90
2725-55G	5-1/2	140	168	5 / 90
2725DK	renewal kits		-	-



2755

FINE GEAR 1/4"

- Reversible ratchet
- 5° gear action degree (72 teeth)
- DIN 3122

KT NO.	Overall length			
	inch	mm		
2755-55G	5-1/2	144	113	5 / 90
2755DK	renewal kits		-	-

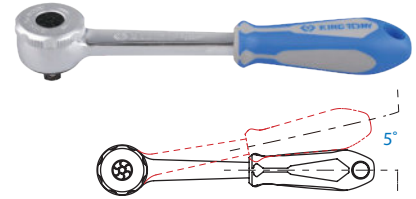

2752

QUICK RELEASE FINE GEAR 1/4"

- Quick release swivel reversible ratchet
- 5° gear action degree (72 teeth)
- Multi-angle design for difficult-to-reach fasteners

KT NO.	Overall length			
	inch	mm		
2752-06G	6	150	128	6 / 108
2752DK	renewal kits		-	-



2752-45G

QUICK RELEASE FINE GEAR 1/4"

- Quick release swivel reversible ratchet
- 5° gear action degree (72 teeth)
- Multi-angle design for difficult-to-reach fasteners
- Application: T-handle ratchet / screwdriver ratchet

KT NO.	Overall length			
	inch	mm		
2752-45G	4-1/2	114	128	6 / 108
2752DK	renewal kits		-	-

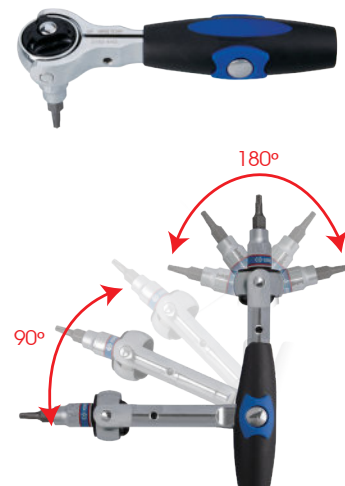

2761

QUICK RELEASE 1/4"

- Quick release reversible ratchet
- 15° gear action degree (24 teeth)
- Two teeth pawl action
- DIN 3122

KT NO.	Overall length			
	inch	mm		
2761-55F	5-1/2	140	164	6 / 108
2761-55P	5-1/2	140	156	6 / 108
2761DK	renewal kits		-	-



Ratchet

KT No. & D1

2769

1/4"

- Reversible ratchet
- 15° gear action degree (24 teeth)
- Two teeth pawl action
- DIN 3122

KT NO.	Overall length			
	inch	mm		
2769-55F	5-1/2	140	167	6 / 108
2769-55P	5-1/2	140	159	6 / 108
2769DK	renewal kits		-	-



2771

QUICK RELEASE

1/4"

- Quick release reversible ratchet
- 15° gear action degree (24 teeth)
- Two teeth pawl action
- DIN 3122

KT NO.	Overall length			
	inch	mm		
2771-55F	5-1/8	130	142	6 / 108
2771-55G	5-1/8	134	110	6 / 108
2771DK	renewal kits		-	-



2773

1/4"

- Quick release reversible ratchet
- 4° gear action degree (90 teeth)
- DIN 3122

KT NO.	Overall length			
	inch	mm		
2773-55GS	5-1/2	140	110	1 / 100
2773DK	renewal kits		-	-



2774

1/4"

- Universal joint reversible ratchet
- 15° gear action degree (24 teeth)
- Two teeth pawl action
- DIN 3122

KT NO.	Overall length			
	inch	mm		
2774-55F	5-1/8	130	146	6 / 108
2774-55G	5-1/8	134	114	6 / 108
2774DK	renewal kits		-	-



2779

1/4"

- Reversible ratchet
- 15° gear action degree (24 teeth)
- Two teeth pawl action
- DIN 3122

KT NO.	Overall length			
	inch	mm		
2779-55F	5-1/8	130	145	6 / 108
2779-55G	5-1/8	134	113	6 / 108
2779DK	renewal kits		-	-



Ratchet

KT No. & D1

2781

QUICK RELEASE

1/4"

- Quick release flexible and reversible ratchet
- 15° gear action degree (24 teeth)
- Two teeth pawl action
- DIN 3122

KT NO.	Overall length			
	inch	mm		
2781-06P	6	150	156	6 / 108
2781DK	renewal kits		-	-



2781DK



2760

MINI RATCHET

1/4"

- Mini reversible ratchet
- 5° gear action degree (72 teeth)
- Two teeth pawl action
- DIN 3122

KT NO.	Overall length			
	inch	mm		
2760-04	4	100	95	8 / 128
2760DK01	renewal kits		-	-



2760DK01



276A

FINE GEAR

MINI RATCHET

1/4"

- Mini bit holder ratchet
- 5° gear action degree (72 teeth)
- Two teeth pawl action

KT NO.	A mm	D mm	L mm	H mm		
276ADK	renewal kits					



276ADK

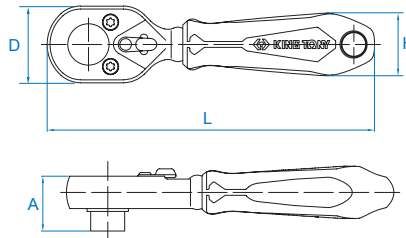

magnet

276A-04G (top, side, back)



Mini Ratchet Set

2515MR

1/4"

- Mini ratchet set
- 5° gear action degree (72 teeth)
- Two teeth pawl action

15 PC.



Contents 0.26 6 / 36

		2335M	5, 5.5, 6, 7, 8
		1025P	PH1, PH2
		1025T	T10, T15, T20
		1025H	H3, H4, H5, H6
		276A-04G	

2501MR

1/4"

- 5° gear action degree (72 teeth)
- Two teeth pawl action

21 PC.



Contents 0.36 4 / 48

		2335M	4, 5, 6, 7, 8, 9, 10, 11, 12, 13
		1025P	PH1, PH2, PH3
		1025T	T10, T20, T30
		1025H	H4, H6
		1025S	5.5x1.0, 6.5x1.2
		276A-04G	



Accessory

2745

1/4"

- Palm ratchet bit holder
- Non-toothed palm ratchet is designed for any angle of degree
- 3 position of forward / lock / reverse
- Suitable for narrow space where a standard wrench cannot attain
- Anodized aluminum alloy body & chrome vanadium alloy steel bit holder

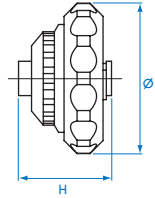

KT NO.	Ø1 mm	H		
2745	46	26.5	103	12 / 144

2747

1/4"

- 72-teeth ratcheting mechanism gives a 5° ratcheting arc allowing you to quickly tighten or loosen fasteners.
- Anodized aluminum finish for protection and easy wipe down



2747DR

2747



- The special gyroscope-like structure allows you to loosen or lock objects with various angles

KT NO.	Ø (mm)	H (mm)	Teeth		
○ 2747	50	25	72	88	12 / 72
■ 2747DR	50	25	72	90	12 / 72

Accessory

- Material - chrome vanadium alloy steel
- Finishing - polished, chrome plated

KT No. & D1



2221

1/4"

- Extension bar
- DIN 3122



KT NO.	Overall length		Scales	Box / Qty
	inch	mm		
2221-02	2	55	27	30 / 480
2221-03	3	75	36	20 / 400
2221-04	4	100	44	15 / 240
2221-06	6	150	67	15 / 240
2221-10	10	254	107	15 / 240
2221-12	12	305	130	15 / 240

2293

1/4"

- Multi-function extension bar and offset extension bar, wobble extension bar
- Hex key is applicable to the hex shank
- Max. torque : 35 N·m
- DIN 3123



KT NO.	Overall length		Scales	Box / Qty
	inch	mm		
2293-02	2	55	24	30 / 480
2293-03	3	75	34	20 / 400
2293-04	4	100	44	15 / 240
2293-06	6	150	65	15 / 300

2311

1/4"

- Flexible extension bar



KT NO.	Overall length		Scales	Box / Qty
	inch	mm		
2311-06	6	150	65	12 / 240
2311-12	12	300	89	12 / 120
2311-18	18	450	112	20 / 200

2312

1/4"

- Flexible extension bar



KT NO.	Overall length		Scales	Box / Qty
	inch	mm		
2312-06	6	150	59	12 / 240



In order to get normal life of bit socket, Always use within limited torque to bit.

3893EW

1/4" & 3/8"

- Extension wrench
- Length extension drive bar enables easier works in confined spaces
- Provided with two square drive adapters in 1/4" and 3/8"
- Chain-driven mechanism enhances working durability and smoothness
- Max torque allowed: 130 N m / 96 ft lb



3/8"
3893EW-01



1/4"
3893EW-02

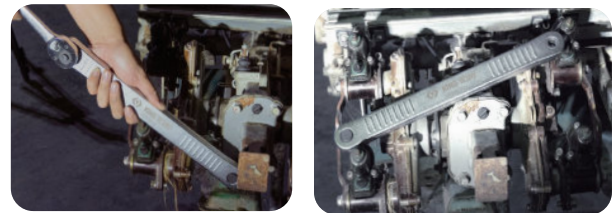

KT NO.	Drive	Overall length inch	Overall length mm	Capacity	Scales	Box / Qty
3893EW		13.4	340	300	410	20 / 40
3893EW-01	3/8"	-	-		20	10 / 160
3893EW-02	1/4"	-	-		20	10 / 160

2223

1/4"

- Offset extension bar, wobble extension bar
- Max. torque: 35 Nm
- DIN 3123



KT NO.	Overall length		Scales	Box / Qty
	inch	mm		
2223-02	2	55	24	30 / 480
2223-04	4	100	44	15 / 240

2792

1/4"

- Universal joint
- DIN 3123



KT NO.	Overall length		Scales	Box / Qty
	inch	mm		
2792	1 - 1/2	36	22	24 / 384

Accessory



2793 1/4"

- Universal joint
- Ball point type universal joint & with hex locking design
- **Short pattern design enables greater access in confined spaces**

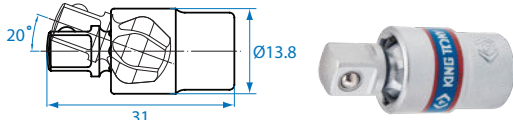

KT NO.	Overall length		g	/
	inch	mm		
2793	1-1/4	31	18	20 / 600

9113PR 1/4" 3/8" 1/2"

- Universal joint
- Ball point type universal joint & with hex locking design
- **Short pattern design enables greater access in confined spaces**



3 PC.

Contents g 0.20 / 6 / 108

KT NO.	Spec.	g	/
2793	31mm		
3793	43mm		
4793	59mm		

2813 1/4"

- Adapter
- Convert to 3/8" drive
- DIN 3123



3/8" drive (M) ← 1/4" drive (F)

KT NO.	Spec.	g	/
2813	1/4" F x 3/8" M	20	12 / 360

213312DF 1/4"

- Magnetic screwdriver handle
- DIN 3126



KT NO.	Overall length		g	/
	inch	mm		
213312DF	12	300	132	2 / 40

2176DF 1/4"

- 2 in 1 design Spinner handle + Bit holder
- NF ISO 3315, ISO 3315, DIN 3122, ASME B107.10



- Attached with 1/4" bit
- Attached with 1/4" DR. socket
- Easy to switch



- Attached with 1/4" DR. ratchet, compact size & easy to use

KT NO.	Overall length		g	/
	inch	mm		
2176DF	6	150	105	6 / 60

2177DF 1/4"

- Spinner handle
- DIN 3122



KT NO.	Overall length		g	/
	inch	mm		
2177DF	12-1/4	310	126	6 / 60

2178DF 2179DF 1/4"

- Spinner handle
- DIN 3122



2178DF (PP + TPR)



2179DF (PP)

KT NO.	Overall length		g	/
	inch	mm		
2178DF	6	150	76	6 / 120
2179DF	6	150	90	12 / 192

2178TG 1/4"

- Spinner handle
- DIN 3122



KT NO.	mm	mm	g	/
2178TG	1/4	115	154	94 / 96

2452 1/4"

- Flexible handle
- Action degree -180°
- DIN 3122



2452DK

KT NO.	Overall length		g	/
	inch	mm		
2452-05F	5	130	86	15 / 270
2452DK	renewal kits			

Accessory

KT No. & D1 



- Material - chrome vanadium alloy steel
- Finishing - polished, chrome plated & black phosphate sunk

2453 1/4"

- Flexible handle
- Action degree -180°
- New pattern design added in firm and powerful elements
- New forge technologies I-Beam shank offers 15% lightweight
- DIN 3122



2452DK

KT NO.	Overall length inch	mm		
2453-05F	5	130	71	15 / 270
2452DK	renewal kits			

2571 1/4"

- Sliding T-handle
- DIN 3122





KT NO.	Overall length inch	mm		
2571-45	4-1/2	115	44	12 / 192

2141 2142 1/4"

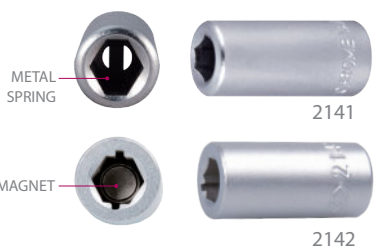
- Bit holder
- DIN 3122



KT NO.	Size inch	Overall length mm		
2141	1/4	25	14.0	20 / 320
2142	1/4	25	15	20 / 320





Socket Rail Set

2509MR 1/4"

- Socket rail 150mmL



9 PC.





Contents			
	2335M 4, 5, 6, 7, 8, 9, 10, 11, 13	0.17	4 / 48
	8720609		

2509SR 1/4"

- Socket rail 150mmL



9 PC.

Contents			
	2335S 5/32, 3/16, 1/4, 9/32, 5/16, 11/32, 3/8, 7/16, 1/2	0.17	4 / 48
	8720609		





Socket Rail Set

2513MR 1/4"

- Socket rail 240 mmL

13 PC.







Contents			
	2335M 4, 4.5, 5, 5.5, 6, 7, 8, 9, 10, 11, 12, 13, 14	0.23	6 / 60
	8721114		

2513MRD1 1/4"

- Socket rail 508 mmL

13 PC.







Contents			
	2335M 4, 4.5, 5, 5.5, 6, 7, 8, 9, 10, 11, 12, 13, 14	0.34	50
	8720813D1		

2311MR 1/4"

- Socket rail 240 mmL

13 PC.







Contents			
	2235M 4, 4.5, 5, 5.5, 6, 7, 8, 9, 10, 11, 12, 13, 14	0.46	6 / 60
	8721114		

2127PR 1/4"

- Socket rail 130mmL
- For hex head screw
- H : 37mm

7 PC.







Contents			
	2035 H3, H4, H5, H6, H7, H8, H10	0.15	4 / 32
	8720507		

2127SR 1/4"

- Socket rail 130mmL
- For hex head screw
- H : 37mm

7 PC.



Contents			
	2035S H1/8, H5/32, H3/16, H7/32, H1/4, H5/16, H3/8	0.15	4 / 32
	8720507		



Socket Rail Set

2109PR

1/4"

- Socket rail 150mmL
- For torx head screw
- H : 37mm

9 PC.



Contents 0.12 4 / 32

	2033	T8, T9, T10, T15, T20, T25, T27, T30, T40
8720609		

2114TR

1/4"

- Socket rail 150mmL
- For torx head screw
- H : 37mm

14 PC.



Contents 0.30 6 / 72

	2033	T8, T9, T10, T15, T20, T25, T27, T30, T40
	2275M	E4, E5, E6, E7, E8
8721114		

2107PR

1/4"

- Socket rail 130mmL
- For tamper resistant torx head screw
- H : 37mm

7 PC.



Contents 0.12 4 / 32

	2037	T10H, T15H, T20H, T25H, T27H, T30H, T40H
8720507		

2119PR

1/4"

- Socket rail 150mmL
- For tamper resistant torx head screw
- H : 37mm

9 PC.



Contents 0.12 4 / 32

	2037	T8H, T9H, T10H, T15H, T20H, T25H, T27H, T30H, T40H
8720609		

872

1/4"

- Rail length from 160 mm to 560 mm

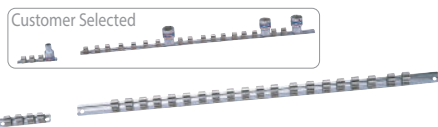

KT NO.	L (mm)
870406	160
870208	200
870422	560
8720	-

8720813D1

1/4"

Socket rail carrier with retaining clip
446mm roller cabinet



KT NO.	Square drive	Clip	L (mm)
8720813D1	1/4"	13	508

Extension Bar Set

2104PR

1/4"



4 PC.

Contents 0.17 1 / 80

	2221	2", 3", 4", 6"
--	------	----------------

Socket Set

2313MR

1/4"



13 PC.

Contents 0.42 1 / 32

	2335M	4, 5, 6, 7, 8, 9, 10, 11, 12, 13, 14
	2766-55G	2221-04

2510SR

1/4"

Metal case size (mm) :
223 x 65 x 32 (0.016 cuft)

10 PC.



Contents 0.62 1 / 30

	2235S	5/32, 3/16, 7/32, 1/4, 9/32, 5/16, 11/32, 3/8, 7/16, 1/2
--	-------	--

2511MR

1/4"

Metal case size (mm) :
223 x 65 x 32 (0.016 cuft)

11 PC.



Contents 0.67 1 / 30

	2235M	4, 5, 5.5, 6, 7, 8, 9, 10, 11, 12, 13
--	-------	---------------------------------------

Atom Series

Asymmetrical line design

2539MR-AM

Plastic case size (mm):
170 x 95 x 51 (0.029 cuft)

39
PC.

PAT.



▪ Push mechanism



▪ Easy to pick up

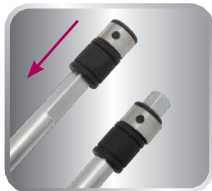
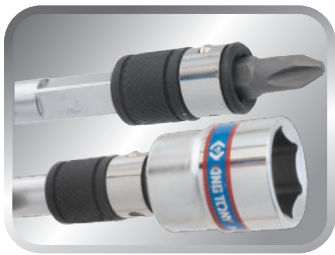

Contents

0.86 1 / 24

	2335M	5, 5.5, 6, 7, 8, 9, 10, 11, 12, 13, 14
	1025P	PH1, PH2, PH3
	102512P	
	1025Z	PZ1, PZ2, PZ3
	1025U	T10H, T15H, T20H, T25H, T27H, T30H, T40H
	1025S	4.0, 5.0, 6.0
	1025H	H2.5, H3, H4, H5, H6
	2773-55GS	2176DF
	2141	2793 2221-02 2221-04



▪ Automatic raising bit rack

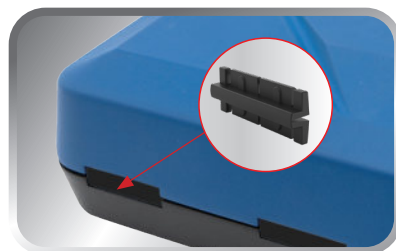

▪ Built-in rotation axis design



Socket Set

2516MR

2516SR

1/4"

Metal case size (mm):
244 x 118 x 37 (0.038 cuft)

16
PC.



2516MR



2516SR

KT NO.	Contents		1.10	1 / 18
2516MR	2335M	4, 4.5, 5, 5.5, 6, 7, 8, 9, 10, 11, 13	2779-55G	2571-45 2179DF
2516SR	2335S	5/32, 3/16, 7/32, 1/4, 9/32, 5/16, 11/32, 3/8, 7/16, 15/32, 1/2	2221-04	2792

2518MR

2518SR

2518MR01

1/4"

Metal case size (mm):
198 x 105 x 32 (0.023 cuft)

18
PC.



2518MR/2518MR01



2518SR

KT NO.	Contents		0.96	1 / 20
2518MR	2335M	4, 4.5, 5, 6, 7, 8, 9, 10, 11, 12	2310M 8, 10	2452-05F 2571-45
2518SR	2335S	5/32, 3/16, 7/32, 1/4, 9/32, 5/16, 11/32, 3/8, 7/16, 1/2	2310S 5/16, 3/8	2725-55F 2792
2518MR01	2335M	4, 4.5, 5, 5.5, 6, 7, 8, 9, 10, 11, 12, 13		2221-02 2221-04

2019MR

2019SR

2519MR

2519SR

1/4"

Metal case size (mm):
198 x 105 x 32 (0.023 cuft)

18
PC.



2019MR/2519MR



2019SR/2519SR

KT NO.	Contents		0.92	1 / 20
2019MR	2330M	4, 4.5, 5, 6, 7, 8, 9, 10, 11, 12	2310M 8, 10	2769-55P 2452-05F
2519MR	2335M			2221-02 2571-45
2019SR	2330S	5/32, 3/16, 7/32, 1/4, 9/32, 5/16, 11/32, 3/8, 7/16, 1/2	2310S 5/16, 3/8	2221-04
2519SR	2335S			2792







Socket Set

2021MR

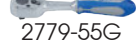
2521MR

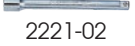
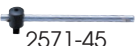
1/4"

Metal case size (mm) :
198 x 105 x 32 (0.023 cuft)

KT NO.	Contents	0.87	1 / 20
2021MR	 2330M 4, 4.5, 5, 5.5, 6, 7, 8, 9, 10, 11, 12, 13	 2779-55G  2452-05F  2792	 2221-02  2221-04  2571-45  2141
2521MR	 2335M		









19 PC.

2525MRE

1/4"

Blow case size (mm) :
203 x 93 x 43 (0.028cuft)

Contents	0.54	1 / 20
 2335M 4, 4.5, 5, 5.5, 6, 7, 8, 9, 10, 11, 12, 13		
 1025P PH2 x2		
 1025H H5, H6		
 1025T T10, T15, T20, T25, T30, T40		
 2771-55G  2221-04  2142		



25 PC.

2027MRE

1/4"

Blow case size (mm) :
203 x 93 x 43 (0.028cuft)











2527MRE

1/4"



27 PC.

KT NO.	Contents	0.60	1 / 20
2027MRE	 2330M 4, 4.5, 5, 5.5, 6, 7, 8, 9, 10, 12, 13, 14	 1025P PH1, PH2  1025H H3, H4, H5  1025T T10, T15, T20, T25, T30, T40	 2221-04  276A-04G  2142  2792
2527MRE	 2335M		

Socket Set

2526MR

Metal case size (mm) :
244 x 118 x 37 (0.038 cuft)



2526MR

2526SR

1/4"

26
PC.



2526SR

KT NO.	Contents		kg 1.30	1 / 18
2526MR	2335M	4, 4.5, 5, 5.5, 6, 7, 8, 9, 10, 11, 13	2779-55G	2221-02 2221-04
	2235M	4, 5, 5.5, 6, 7, 8, 9, 10, 11, 13		
2526SR	2335S	5/32, 3/16, 7/32, 1/4, 9/32, 5/16, 11/32, 3/8, 7/16, 15/32, 1/2	2792	2813
	2235S	5/32, 3/16, 7/32, 1/4, 9/32, 5/16, 11/32, 3/8, 7/16, 1/2		

2031MR

Metal case size (mm) :
280 x 130 x 41 (0.053 cuft)

KT NO.	Contents		kg 1.60	1 / 15
2031MR	2330M	4, 4.5, 5, 6, 7, 8, 9, 10, 11, 12, 13	T8, T9, T10, T15, 2033 H3, H4, H5, H6, 2035 H8, H10 2779-55G 2179DF 2571-45	2221-03 2221-06 2792
2531MR	2335M			

2531MR

1/4"

31
PC.



2030CR

Metal case size (mm) :
244 x 118 x 37 (0.038 cuft)



30
PC.

2530CR 1/4"

KT NO.	Contents		kg 1.30	1 / 18
2030CR	2330M	4, 4.5, 5, 6, 7, 8, 9, 10, 11, 12	2769-55F 2792	2310M 8, 10 2310S 5/16, 3/8
	2330S	5/32, 3/16, 7/32, 1/4, 9/32, 5/16, 11/32, 3/8, 7/16, 1/2		
2530CR	2335M	4, 4.5, 5, 6, 7, 8, 9, 10, 11, 12	2571-45 2452-05F	2221-02 2221-04
	2335S	5/32, 3/16, 7/32, 1/4, 9/32, 5/16, 11/32, 3/8, 7/16, 1/2		

2539MR

Metal case size (mm) :
280 x 130 x 41 (0.053 cuft)



39
PC.

Contents		kg 1.61	1 / 15
2335M	4, 4.5, 5, 5.5, 6, 7, 8, 9, 10, 11, 12, 13	2779-55G 2179DF	2221-02 2221-04 2792
2375M	E4, E5, E6, E7, E8		
2033	T8, T9, T10, T15, T20, T25, T27, T30, T40		
2035	H3, H4, H5, H6, H7, H8, H10		
2571-45			

Socket Set

2540MR

1/4"

Metal case size (mm):
316 x 104 x 40 (0.047 cuft)



39
PC.

Contents

1.52 kg / 1 / 12

2335M	4, 4.5, 5, 5.5, 6, 7, 8, 9, 10, 11, 12, 13
1025S	4, 5.5, 7
1025P	PH0, PH1, PH2, PH3
1025H	H3, H4, H5, H6, H7, H8
1025T	T10, T15, T20, T25, T30, T40
2779-55G	213312DF 2792 2141
2571-45	2452-05F 2221-02 2221-06

2575MR

1/4"

Metal case size (mm):
244 x 118 x 37 (0.038 cuft)

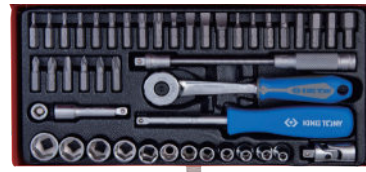

45
PC.

Contents

1.24 kg / 1 / 18

2335M	4, 5, 5.5, 6, 7, 8, 9, 10, 11, 12, 13, 14
1025S	4, 6.5, 7, 8
1025P	PH1, PH2, PH3
1025H	H2.5, H3, H4, H5, H6, H7, H8, H10
1025U	T8H, T9H, T10H, T15H, T20H, T25H, T27H, T30H, T40H
1025Z	PZ1, PZ2, PZ3
2755-55G	2223-02 2792
2311-06	2179DF 2142

2551MR

Metal case size (mm):
244 x 118 x 37 (0.038 cuft)



2551MR



2551MR01

51
PC.

KT NO.

Contents

1.30 kg / 1 / 18

2551MR	2755-55G	2335M	4, 5, 5.5, 6, 7, 8, 9, 10, 11, 12, 13, 14	1025U	T10H, T15H, T20H, T25H, T27H, T30H, T40H	2813	2142	2792
		1025S	3, 4, 5, 6	1025Z	PZ1, PZ2 x2, PZ3	7702-25	753-63	
2551MR01	2761-55F	1025P	PH1, PH2 x2, PH3	1025T	T10, T15, T20, T25, T27, T30, T40	2223-02	2178DF	2223-04
		1025H	H3, H4, H5, H6					

2516MRV03

Plastic case size (mm):
199 x 161 x 56 (0.063 Cuft)

Tray category #11 (187 x 140mm) 1/4"

Contents

0.75 kg / 1 / 16

2335M	4, 4.5, 5, 5.5, 6, 7, 8, 9, 10, 11, 12, 13, 14
2771-55G	2571-45
2221-06	2792



17
PC.

2524MRV

Plastic case size (mm):
199 x 161 x 56 (0.063 Cuft)

Tray category #11 (187 x 140mm) 1/4"

Contents

0.9 kg / 1 / 16

2335M	4, 4.5, 5, 5.5, 6, 7, 8, 9, 10, 11, 12, 13, 14
2771-55G	2571-45 2142
2221-02	2221-04 2221-06
2178DF	2792



21
PC.















Socket Set

2528MRV

Tray category #11 (187 x 140mm) 1/4"

Plastic case size (mm) :
199x 161 x 56 (0.063 Cuft)

Contents  0.76  /  1 / 6

		2335M	4, 4.5, 5, 5.5, 6, 7, 8, 9, 10, 11, 12, 13, 14
		1025H	H3, H4, H5, H6
		1025S	4, 5
		1025T	T10, T15, T20, T30
		1025P	PH1, PH2
		276A-04G	2792
		2221-06	2142















29
PC.

2331SRV

Tray category #7 (280 x 187mm) 1/4"

Plastic case size (mm) :
289 x 230 x 66 (0.154Cuft)

Contents  1.63  /  1 / 6

		2335S	5/32, 3/16, 7/32, 1/4, 9/32, 5/16, 11/32, 3/8, 7/16, 15/32, 1/2, 9/16
		2235S	5/32, 3/16, 7/32, 1/4, 9/32, 5/16, 11/32, 3/8, 7/16, 1/2, 9/16
		2771-55G	2571-45
		2221-02	2142
		2221-04	2178DF
		2221-06	2178DF

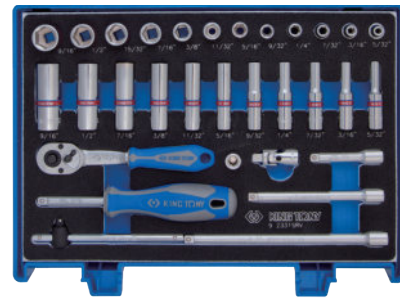













31
PC.

2534MRV

Tray category #7 (280 x 187mm) 1/4"

Plastic case size (mm) :
289 x 230 x 66 (0.154Cuft)

Contents  1.76  /  1 / 6

		2335M	4, 4.5, 5, 5.5, 6, 7, 8, 9, 10, 11, 12, 13, 14
		2235M	4, 4.5, 5, 5.5, 6, 7, 8, 9, 10, 11, 12, 13, 14
		2771-55G	2571-45
		2221-02	2142
		2221-04	2178DF
		2221-06	2792

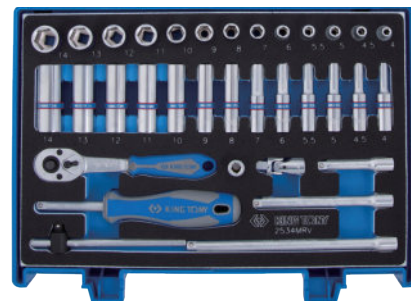





















34
PC.

2565MRV

Tray category #7 (280 x 187mm) 1/4"

Plastic case size (mm) :
289 x 230 x 66 (0.154 cuft)

Contents  2.67  /  1 / 6

		2335M	4, 4.5, 5, 5.5, 6, 7, 8, 9, 10, 11, 12, 13, 14
		2235M	4, 4.5, 5, 5.5, 6, 7, 8, 9, 10, 11, 12, 13, 14
		2375M	E4, E5, E6, E7, E8
		2013X	T8, T9, T10, T15, T20, T25, T27, T30, T40
		2015X	3, 4, 5, 6, 8
		2018X	PZ1, PZ2
		2011X	PH1, PH2
		2012X	3.5, 5.5, 8
		1025T	T6, T7
		1025M	M4, M5, M6, M8, M10



65
PC.

Contents

				2221-02
2792	2813	276A-04G		2221-04
				2221-06

Socket Set

2044SRV

Plastic case size (mm) :
389 x 185 x 66 (0.168 Cuft)

















2044SRV

2544SRV Tray category #10 (375 x 140mm) 1/4"



2544SRV

44
PC.

KT NO.	Contents		1.62 kg	1 / 10
2044SRV	 2330S	5/32, 3/16, 7/32, 1/4, 9/32, 5/16, 11/32, 3/8, 7/16, 15/32, 1/2	 2142  2792  2223-02  2223-04  2752-06G  2178DF	
2544SRV	 2335S		 2142  2792  2223-02  2223-04  2752-06G  2178DF	

2048MRV

Plastic case size (mm) :
389 x 185 x 66 (0.168 Cuft)

















2048MRV

2548MRV Tray category #10 (375 x 140mm) 1/4"



2548MRV

48
PC.

KT NO.	Contents		1.79 kg	1 / 10
2048MRV	 2330M	4, 4.5, 5, 5.5, 6, 7, 8, 9, 10, 11, 12, 13, 14	 2142  2792  2223-02  2223-04  2178DF  2752-06G	
2548MRV	 2335M		 2142  2792  2223-02  2223-04  2178DF  2752-06G	

Socket Set











2553MRV

Plastic case size (mm) :
389 x 185 x 66 (0.168 Cuft)

Tray category #10 (375 x 140mm) 1/4"

Contents

1.67 kg 1 / 10

 2335M	4, 4.5, 5, 5.5, 6, 7, 8, 9, 10, 11, 12, 13, 14
 1025H	H3, H4, H5, H6, H7, H8, H10
 1025S	3, 4.5, 5, 6.5, 8
 1025P	PH0, PH1, PH2, PH3
 1025U	T10H, T15H, T20H, T25H, T27H, T30H, T40H
 1025Z	PZ1, PZ2, PZ3
 1025T	T10, T15, T20, T25, T27, T30, T40
 7702-25	 2792
	 2813



53
PC.

Contents

 276A-04G	 213312DF
 2223-02	 2745
 2223-04	

2553MRV01

Tray category #10 (375 x 140mm) 1/4"

Plastic case size (mm) :
389 x 185 x 66 (0.168 Cuft)

Contents

1.87  1/10

	2335M	4, 4.5, 5, 5.5, 6, 7, 8, 9, 10, 11, 12, 13, 14
	1025H	H3, H4, H5, H6, H7, H8, H10
	1025T	T10, T15, T20, T25, T27, T30, T40
	1025U	T10H, T15H, T20H, T25H, T27H, T30H, T40H
	1025P	PH1, PH2, PH3
	1025Z	PZ1, PZ2, PZ3
	1025S	3, 4.5, 5, 6.5, 8
	7702-25	 276A-04G

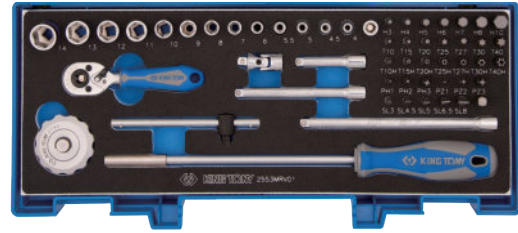

55
PC.

Contents

	2571-45		213312DF
	2221-02		2745
	2221-04		2792
	2221-06		2142













2550MRV

Tray category #8 (375 x 187mm) 1/4"

Plastic case size (mm) :
389 x 230 x 66 (0.208 Cuft)

Contents

2.2  1/6

	2335M	4, 4.5, 5, 5.5, 6, 7, 8, 9, 10, 11, 12, 13, 14
	2375M	E4, E5, E6, E7, E8
	2031	PH1, PH2, PH3, PH4
	2032	4, 5.5, 6.5, 8, 10
	2033	T8, T9, T10, T15, T20, T25, T27, T30, T40
	2035	H3, H4, H5, H6, H7, H8, H10
	2771-55G	 2178DF
	2571-45	 2792
	2293-04	 2221-02
	2293-06	











50
PC.

2549MR-EB

Contents

1.28  1/12

	2335M	4, 4.5, 5, 5.5, 6, 7, 8, 9, 10 x2, 11, 12, 13, 14
	2235M	4, 4.5, 5, 5.5, 6, 7, 8, 9, 10, 11, 12, 13, 14
	2275M	E4, E5, E6, E7, E8
	2375M	E4, E5, E6, E7, E8, E10
	2031	PH1, PH2
	2032	4, 5.5
	2035	H3, H4, H5, H6, H8
	2221-02	



49
PC.



Standard Socket

3330M

- Metric-DIN 3124, ISO 2725-1
- Inch-ANSI / ASME B107.1

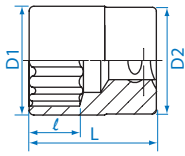

KT NO.	mm	D1 mm	D2 mm	l mm	L mm	⚖️	📦
333006M	6	9.9	17.8	7.0	27	25	12 / 360
333007M	7	10.8	17.8	7.0	27	24	12 / 360
333008M	8	12.0	17.8	7.0	27	25	12 / 360
333009M	9	13.2	17.8	7.0	27	25	12 / 360
333010M	10	14.5	17.8	9.0	27	26	12 / 360
333011M	11	15.8	17.8	9.0	27	27	12 / 360
333012M	12	16.8	17.8	9.0	27	26	12 / 360
333013M	13	17.8	16.8	9.0	27	25	12 / 360
333014M	14	19.7	18.0	11.0	29	33	10 / 300
333015M	15	20.8	18.0	11.0	29	35	10 / 300
333016M	16	21.8	20.0	11.0	29	45	10 / 300
333017M	17	23.8	20.0	11.0	29	48	10 / 200
333018M	18	24.7	21.0	13.0	29	50	10 / 200
333019M	19	25.8	21.0	13.0	29	51	10 / 200
333020M	20	27.1	25.0	13.0	32	83	10 / 160
333021M	21	27.8	25.0	13.0	32	80	10 / 160
333022M	22	29.7	26.0	15.0	32	86	10 / 160
333023M	23	29.7	26.0	15.0	32	80	10 / 160
333024M	24	31.8	26.0	17.0	32	89	8 / 160

KT NO.	inch	D1 mm	D2 mm	l mm	L mm	⚖️	📦
333008S	1/4	10.0	17.8	7.0	27	24	12 / 360
333010S	5/16	12.0	17.8	7.0	27	24	12 / 360
333011S	11/32	13.2	17.8	7.0	27	25	12 / 360
333012S	3/8	14.0	17.8	9.0	27	26	12 / 360
333014S	7/16	15.8	17.8	9.0	27	26	12 / 360
333015S	15/32	16.8	17.8	9.0	27	27	12 / 360
333016S	1/2	17.8	16.8	9.0	27	26	12 / 360
333018S	9/16	19.7	18.0	11.0	29	33	10 / 300
333019S	19/32	20.8	18.0	11.0	29	35	10 / 300
333020S	5/8	21.8	20.0	11.0	29	42	10 / 300
333022S	11/16	23.8	20.0	11.0	29	46	10 / 200
333024S	3/4	25.8	21.0	13.0	29	50	10 / 200
333026S	13/16	27.8	25.0	13.0	32	80	10 / 160
333028S	7/8	29.7	26.0	15.0	32	83	10 / 160
333030S	15/16	31.8	26.0	17.0	34	83	8 / 160
333032S	1	33.8	26.0	17.0	34	96	8 / 160

3335M

- Metric-DIN 3124, ISO 2725-1
- Inch-ANSI / ASME B107.1

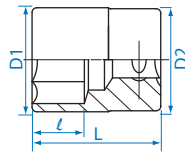

KT NO.	mm	D1 mm	D2 mm	l mm	L mm	⚖️	📦
333506M	6	9.9	17.8	7.0	27	25	12 / 360
333507M	7	10.8	17.8	7.0	27	24	12 / 360
333508M	8	12.0	17.8	7.0	27	26	12 / 360
333509M	9	13.2	17.8	7.0	27	25	12 / 360
333510M	10	14.5	17.8	9.0	27	28	12 / 360
333511M	11	15.8	17.8	9.0	27	27	12 / 360
333512M	12	16.8	17.8	9.0	27	28	12 / 360
333513M	13	17.8	16.8	9.0	27	26	12 / 360
333514M	14	19.7	18.0	11.0	29	35	10 / 300
333515M	15	20.8	18.0	11.0	29	39	10 / 300
333516M	16	21.8	20.0	11.0	29	43	10 / 300
333517M	17	23.8	20.0	11.0	29	50	10 / 200
333518M	18	24.7	21.0	13.0	29	51	10 / 200
333519M	19	25.8	21.0	13.0	29	53	10 / 200
333520M	20	27.1	25.0	13.0	32	87	10 / 160
333521M	21	27.8	25.0	13.0	32	82	10 / 160
333522M	22	29.7	26.0	15.0	32	89	10 / 160
333523M	23	29.7	26.0	15.0	32	84	10 / 160
333524M	24	31.8	26.0	17.0	32	94	8 / 160

KT NO.	inch	D1 mm	D2 mm	l mm	L mm	⚖️	📦
333508S	1/4	10.0	17.8	7.0	27	24	12 / 360
333510S	5/16	12.0	17.8	7.0	27	25	12 / 360
333511S	11/32	13.2	17.8	7.0	27	24	12 / 360
333512S	3/8	14.0	17.8	9.0	27	25	12 / 360
333514S	7/16	15.8	17.8	9.0	27	25	12 / 360
333515S	15/32	16.8	17.8	9.0	27	27	12 / 360
333516S	1/2	17.8	16.8	9.0	27	26	12 / 360
333518S	9/16	19.7	18.0	11.0	29	32	10 / 300
333519S	19/32	20.8	18.0	11.0	29	35	10 / 300
333520S	5/8	21.8	20.0	11.0	29	43	10 / 300
333522S	11/16	23.8	20.0	11.0	29	48	10 / 200
333524S	3/4	25.7	21.0	13.0	29	51	10 / 200
333526S	13/16	27.8	25.0	13.0	32	83	10 / 160
333528S	7/8	29.6	26.0	15.0	32	89	10 / 160
333530S	15/16	31.8	26.0	17.0	34	86	8 / 160
333532S	1	33.8	26.0	17.0	34	101	8 / 160

Thin Wall Deep Socket

3215M

- Specifically for heat plug, glow plug

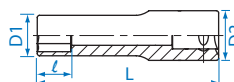

Thin walled design (D1)

KT NO.	mm	D1 mm	D2 mm	l mm	L mm	⚖️	📦
321510M	10	13.0	17.8	12.0	65	49	20 / 240
321512M	12	15.0	17.8	15.0	65	49	20 / 240

Deep Socket

3230M

- Metric-DIN 3124, ISO 2725-1
- Inch-ANSI / ASME B107.1

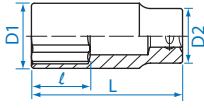

3230S 3/8"



KT NO.	mm	D1 mm	D2 mm	l mm	L mm	g	kg
323007M	7	10.8	17.8	10.0	63	55	20 / 320
323008M	8	12.0	17.8	12.0	63	49	18 / 288
323009M	9	13.2	17.8	12.0	63	57	18 / 288
323010M	10	14.5	17.8	12.0	63	57	15 / 240
323011M	11	15.8	17.8	15.0	63	57	15 / 240
323012M	12	16.8	17.8	15.0	63	58	15 / 240
323013M	13	17.8	16.8	15.0	63	57	15 / 240
323014M	14	19.7	18.0	16.0	63	73	12 / 192
323015M	15	20.8	18.0	18.0	63	73	10 / 160
323016M	16	21.8	20.0	18.0	63	87	8 / 128
323017M	17	23.8	20.0	18.0	63	101	8 / 128
323018M	18	24.7	21.0	20.0	63	107	6 / 96
323019M	19	25.8	21.0	20.0	63	113	6 / 96
323021M	21	27.8	25.0	20.0	63	122	6 / 96
323022M	22	29.7	26.0	20.0	63	150	6 / 96
323024M	24	31.8	26.0	25.0	63	158	6 / 120

KT NO.	inch	D1 mm	D2 mm	l mm	L mm	g	kg
323008S	1/4	10.0	16.8	10.0	63	48	20 / 320
323010S	5/16	12.0	17.8	12.0	63	48	18 / 288
323012S	3/8	14.0	17.8	12.0	63	53	15 / 240
323014S	7/16	15.8	17.8	15.0	63	54	15 / 240
323016S	1/2	17.8	16.8	15.0	63	58	15 / 240
323018S	9/16	19.7	18.0	16.0	63	74	12 / 192
323020S	5/8	21.8	20.0	18.0	63	88	8 / 128
323022S	11/16	23.8	20.0	18.0	63	98	8 / 128
323024S	3/4	25.8	21.0	20.0	63	111	6 / 96
323026S	13/16	27.8	25.0	20.0	63	125	6 / 96
323028S	7/8	29.7	26.0	21.0	63	158	6 / 96
323030S	15/16	31.8	26.0	22.0	63	170	5 / 80
323032S	1	33.8	26.0	22.0	63	195	5 / 80

3235M

- Metric-DIN 3124, ISO 2725-1
- Inch-ANSI / ASME B107.1

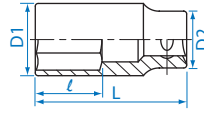

3235S 3/8"



KT NO.	mm	D1 mm	D2 mm	l mm	L mm	g	kg
323506M	6	9.9	17.8	10.0	63	51	20 / 320
323507M	7	10.8	17.8	10.0	63	52	20 / 320
323508M	8	12.0	17.8	12.0	63	49	18 / 288
323509M	9	13.2	17.8	12.0	63	53	18 / 288
323510M	10	14.5	17.8	12.0	63	58	15 / 240
323511M	11	15.8	17.8	15.0	63	60	15 / 240
323512M	12	16.8	17.8	15.0	63	68	15 / 240
323513M	13	17.8	16.8	15.0	63	64	15 / 240
323514M	14	19.7	18.0	16.0	63	77	12 / 192
323515M	15	20.8	18.0	18.0	63	75	10 / 160
323516M	16	21.8	19.0	18.0	63	86	8 / 128
323517M	17	23.8	20.0	18.0	63	102	8 / 128
323518M	18	24.7	21.0	20.0	63	112	6 / 96
323519M	19	25.8	21.0	20.0	63	111	6 / 96
323521M	21	27.8	25.0	20.0	63	142	6 / 96
323522M	22	29.7	26.0	20.0	63	167	6 / 96
323524M	24	31.8	26.0	25.0	63	171	6 / 120

KT NO.	inch	D1 mm	D2 mm	l mm	L mm	g	kg
323508S	1/4	10.0	16.8	10.0	63	47	20 / 320
323510S	5/16	12.0	17.8	12.0	63	56	18 / 288
323512S	3/8	14.0	17.8	12.0	63	56	15 / 240
323514S	7/16	15.8	17.8	15.0	63	59	15 / 240
323516S	1/2	17.8	16.8	15.0	63	41	15 / 240
323518S	9/16	19.7	18.0	16.0	63	76	12 / 192
323520S	5/8	21.8	20.0	18.0	63	90	8 / 128
323522S	11/16	23.8	20.0	18.0	63	97	8 / 128
323524S	3/4	25.8	21.0	20.0	63	108	6 / 96
323526S	13/16	27.8	25.0	20.0	63	146	6 / 96
323528S	7/8	29.7	26.0	21	63	166	6 / 96
323530S	15/16	31.8	26.0	22	63	182	5 / 80
323532S	1	33.8	26.0	22	63	206	5 / 80



Star Socket

KT No. & D1



3375M

3/8"

- DIN 3120

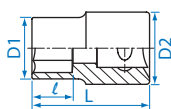

KT NO.	Size	D1 mm	D2 mm	ℓ mm	L mm	⚖️	📦
337504M	E4	6.0	16.8	3.6	28	21	12 / 360
337505M	E5	7.0	16.8	4.0	28	21	12 / 360
337506M	E6	8.0	16.8	5.0	28	22	12 / 360
337507M	E7	8.9	16.8	6.0	28	22	12 / 360
337508M	E8	10.0	16.8	6.5	28	23	12 / 360
337510M	E10	12.0	16.8	7.0	28	24	12 / 360
337511M	E11	12.8	16.8	8.0	28	24	12 / 360
337512M	E12	14.3	16.8	9.0	28	26	12 / 360
337514M	E14	15.9	17.8	9.5	28	31	12 / 360
337516M	E16	18.0	19.8	10.5	28	42	10 / 300
337518M	E18	20.0	21.8	11.0	28	55	10 / 300

3275M

3/8"

- DIN 3120

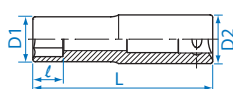

KT NO.	Size	D1 mm	D2 mm	ℓ mm	L mm	⚖️	📦
327504M	E4	6.0	16.8	3.6	63	45	12 / 240
327505M	E5	7.0	16.8	4.0	63	47	12 / 240
327506M	E6	8.0	16.8	5.0	63	48	12 / 240
327507M	E7	8.9	16.8	6.0	63	49	12 / 240
327508M	E8	10.0	16.8	6.5	63	52	12 / 240
327510M	E10	12.0	16.8	7.0	63	57	12 / 240
327511M	E11	12.8	16.8	8.0	63	59	12 / 240
327512M	E12	14.3	16.8	9.0	63	65	12 / 240
327514M	E14	15.9	16.8	9.5	63	67	12 / 240
327516M	E16	17.8	17.8	10.5	63	77	12 / 240
327518M	E18	19.8	19.8	11.0	63	100	10 / 160

333E

3/8"

- For torx plus external screw
- DIN 3120

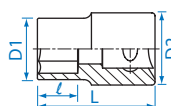

KT NO.	Size	D1 mm	D2 mm	ℓ mm	L mm	⚖️	📦
333E10M	EP10	13.2	10.5	8	37	53	20 / 240
333E11M	EP11	14.0	11.0	9	37	53	20 / 240
333E12M	EP12	14.6	12.0	10	37	53	20 / 240
333E14M	EP14	16.5	14.0	11	37	55	20 / 240
333E16M	EP16	19.0	16.0	12	37	59	20 / 240
333E18M	EP18	20.3	18.0	15	37	60	20 / 240
333E20M	EP20	21.8	19.5	15	37	63	20 / 240





KING TONY Spark Plug Sockets								
Square drive	Type	Size / KT NO.		Rubber I	Magnet	Rubber II	Metal clip	Spring
		Inch	mm					
3/8"	6PT		14	36B014				
			14	36B514				
		5/8"	16	363516	366516		367516	
			18				367518	
	12PT	13/16"	20.8	363521	366521		367521	
			14			36C014		36A014
			14			36D014		
		5/8"	16	363016				
			18	36B018			367018	
		13/16"	20.8	363021	366021		367021	
1/2"	6PT		14	463514RC			467514C	
		5/8"	16	463516RC	466516C		467516	
		13/16"	20.8	463521RC	466521C		467521	
	12PT		14	463014RC			467014C	
		5/8"	16	463016RC	466016		467016	
		13/16"	20.8	463021RC	466021		467021	

Metal Clip Universal Joint Spark Plug Socket

3650

- Inside sleeve - Metal clip for a firm hold and assembly of the spark plugs
- Universal joint- for working in restricted access and obstructive areas
- 12-point socket enables application on 14mm spark plugs of 6-point and 12-point
- Application: For 14 mm spark plugs e.g. BMW and MERCEDES-BENZ
- DIN 3120

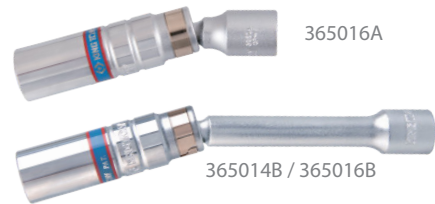

KT NO.	inch	mm	D mm	L mm		
365014B	-	14.0	18.5	155	169	6 / 120
365016A	5/8	16.0	21.0	101	130	6 / 180
365016B	5/8	16.0	21.0	162	185	6 / 120

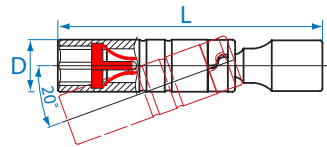

36A0

36B0 36C0 36D0

- Inside sleeve - rubber and spring
- DIN 3120
- 36C014 & 36D014 are suitable for BMW, Mini, RENAULT Clio / Twingo / Kangoo type, PEUGEOT 206 1.4 16V, CITROEN C5 HPI

KT NO.	Type	Size mm	D mm	L mm		
36A014	12 points	14.0	18.5	63	65	12 / 192
36B514	6 points	14.0	18.5	63	63	12 / 192
36B014	12 points	14.0	18.5	63	59	12 / 192
36B018	12 points	18.0	24.7	65	104	8 / 128
36C014	12 points	14.0	18.5	90	90	12 / 144
36D014	12 points	14.0	18.5	250	297	6 / 54

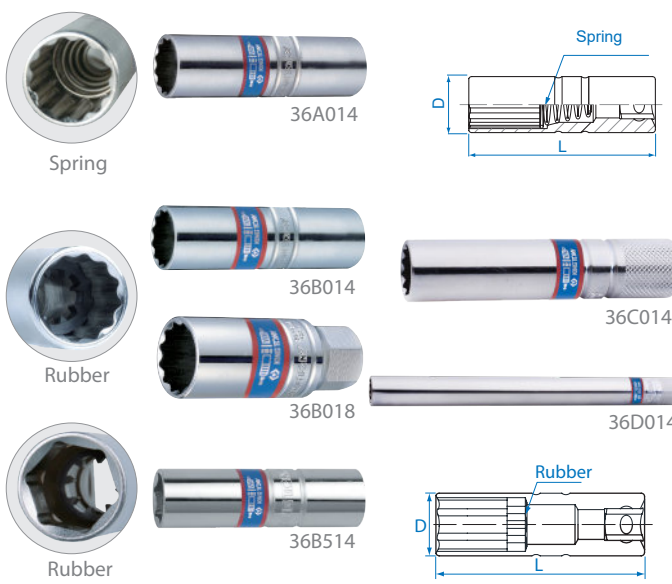

Spark Plug Socket

KT No. & D1



3630



3660



3635



3665



3670



3675

3/8"

- 6 / 12 points
- Size combined- 16.0mm (5/8") - 20.8mm (13/16")
- Inside sleeve - rubber / magnet
- DIN 3120



KT NO.	Type	Size		D mm	L mm	Weight (g)	Pcs / Box
		inch	mm				
363016	12 points Rubber	5/8	16.0	21	70	85	10 / 200
363021	12 points Rubber	13/16	20.8	27.7	70	149	12 / 120
366021	12 points Magnet	13/16	20.8	27.7	70	149	12 / 120
363516	6 points Rubber	5/8	16.0	21	70	88	10 / 200
363521	6 points Rubber	13/16	20.8	27.7	70	153	12 / 120
366516	6 points Magnet	5/8	16.0	21	70	89	10 / 200
366521	6 points Magnet	13/16	20.8	27.7	70	155	12 / 120
367018	12 points Metal clip	-	18.0	23.8	63	84	12 / 120
367021	12 points Metal clip	13/16	20.8	27.7	70	167	12 / 120
367516	6 points Metal clip	5/8	16.0	21.0	70	86	10 / 200
367518	6 points Metal clip	-	18.0	23.8	63	91	12 / 120
367521	6 points Metal clip	13/16	20.8	27.7	70	169	12 / 120



363016



363021



366021



363516



366516



363521



366521

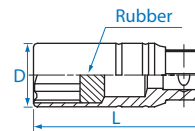

Rubber

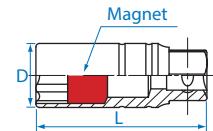

Magnet



367516



367018

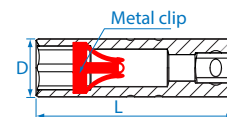

Metal clip

Glow Plug Socket & Set

3785M

3/8"

- The socket has a Sprung-loaded clip with ball bearing end to stop the glow plug from falling out
- Suitable for the removal of glow plugs in most diesel engines



3716MR

3/8"

Blow case size (mm):
260 x 160 x 64 (0.094 cuft)

6 PC.



KT NO.	mm	D1 mm	D2 mm	L mm	Weight (g)	Pcs / Box
378508M	8	13.5	17.8	118	131	10 / 100
378509M	9	13.5	17.8	118	120	10 / 100
378510M	10	13.5	17.8	118	123	10 / 100
378512M	12	17.8	17.8	118	147	10 / 100
378514M	14	17.8	17.8	118	139	10 / 100
378516M	16	19.8	17.8	118	154	10 / 100

Contents

1.23

1 / 10

3785M 8, 9, 10, 12, 14, 16





Flexible Ring Socket Wrench & Set

3350M 

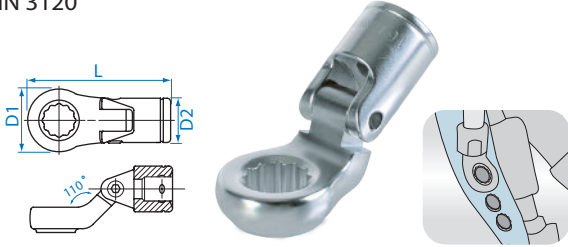
- Flexible head folds up to 200°
- Combined with F-handle, handle, T-handle speed-handle
- Suitable for all hydraulic, fuel, oil brake, A/C, auto tool and air line work
- DIN 3120







KT NO.	 mm	D1 mm	D2 mm	L mm		
335008M	8	15.0	18.8	45.0	44	12 / 360
335009M	9	18.0	18.8	49.0	48	12 / 360
335010M	10	18.0	18.8	49.0	49	12 / 360
335011M	11	22.0	18.8	53.0	58	12 / 360
335012M	12	22.0	18.8	53.0	58	12 / 360
335013M	13	26.0	18.8	60.0	80	12 / 240
335014M	14	26.0	18.8	60.0	82	12 / 240
335015M	15	27.0	18.8	60.0	80	12 / 240
335016M	16	32.0	24.7	73.5	159	6 / 96
335017M	17	33.0	24.7	73.5	159	6 / 96
335018M	18	33.0	24.7	73.5	156	6 / 96
335019M	19	32.0	24.7	73.5	161	6 / 96

Flexible Crowfoot Socket Wrench & Set

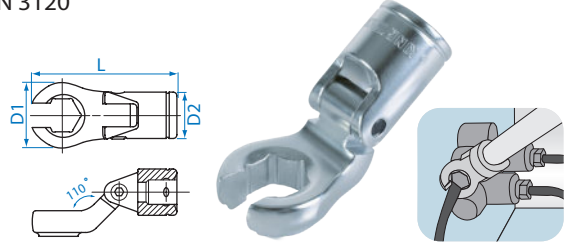
3351M 

- Flexible head folds up to 200°
- Combined with F-handle, handle, T-handle speed-handle
- Suitable for all hydraulic, fuel, oil brake, A/C, auto tool and air line work
- DIN 3120







KT NO.	 mm	D1 mm	D2 mm	L mm		
335108M	8	15.0	18.8	45.0	45	12 / 360
335109M	9	18.0	18.8	49.0	48	12 / 360
335110M	10	18.0	18.8	49.0	49	12 / 360
335111M	11	22.0	18.8	53.0	57	12 / 360
335112M	12	22.0	18.8	53.0	57	12 / 360
335113M	13	26.0	18.8	60.0	77	12 / 240
335114M	14	26.0	18.8	60.0	76	12 / 240
335115M	15	27.0	18.8	60.0	76	12 / 240
335116M	16	32.0	24.7	73.5	153	6 / 96
335117M	17	33.0	24.7	73.5	152	6 / 96
335118M	18	33.0	24.7	73.5	150	6 / 96
335119M	19	33.3	24.7	73.5	153	6 / 96

3609MR10 

- Socket rail 290mmL







Contents			
	3350M 8, 10, 12, 13, 14, 16, 17, 18, 19	0.99	20
8731109			

3619MR10 

- Socket rail 290mmL



Contents			
	3351M 8, 10, 12, 13, 14, 16, 17, 18, 19	0.89	20
8731109			

3612MR 

Metal case size (mm):
296 x 130 x 41 (0.056 cuft)

Contents			
	3351M 8, 9, 10, 11, 12, 13, 14, 15, 16, 17, 18, 19	1.89	1 / 10



Universal Socket & Set

KT No. & D1



3750M

- Chrome vanadium alloy steel
- DIN 3120

KT NO.	mm	D1 mm	D2 mm	ℓ mm	L mm	⚖️	📦
375010M	10	14.5	19	4.6	49.5	56	15 / 240
375011M	11	15.8	19	5.4	50.5	57	15 / 240
375012M	12	17.0	19	6.1	51.0	57	15 / 240
375013M	13	18.3	19	6.7	52.0	56	15 / 240
375014M	14	20.0	19	8.3	52.0	60	12 / 192
375015M	15	22.0	19	8.3	54.5	66	10 / 160
375016M	16	22.0	19	9.5	54.5	63	10 / 160
375017M	17	24.0	19	9.5	55.5	71	8 / 128
375018M	18	26.0	19	10	55.5	75	6 / 96
375019M	19	26.0	19	11	57.5	72	6 / 96

3750S

3/8"

- Chrome vanadium alloy steel

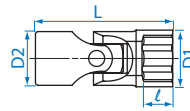

KT NO.	inch	D1 mm	D2 mm	ℓ mm	L mm	⚖️	📦
375012S	3/8	14.0	19	4.6	49.0	56	15 / 240
375014S	7/16	15.8	19	5.4	50.5	58	15 / 240
375016S	1/2	18.3	19	6.7	52.0	59	15 / 240
375018S	9/16	20.0	19	8.3	52.0	60	12 / 192
375020S	5/8	22.0	19	9.5	54.5	65	10 / 160
375022S	11/16	24.0	19	9.5	55.5	65	8 / 128
375024S	3/4	26.0	19	11.0	57.5	74	6 / 96

3709MR10

3/8"

- Socket rail 240mmL



9 PC.

Contents

⚖️ 0.6 📦 14

🔧 3750M 10, 11, 12, 13, 14, 16, 17, 18, 19

— 8730907

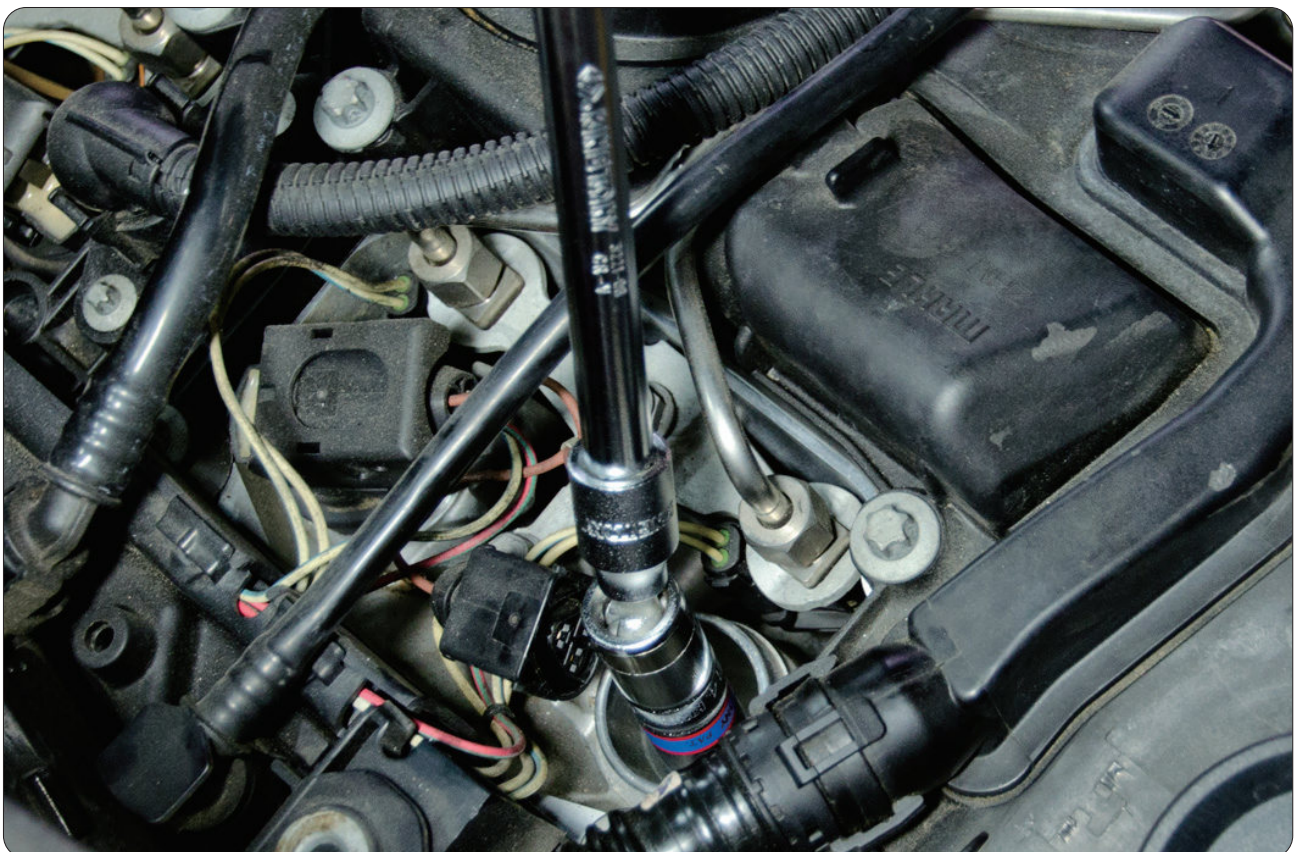

Bit Socket



In order to get normal life of bit socket, always use within limited torque to bit.



3021



- Phillips head
- DIN ISO 8764-1



KT NO.	⊕ No.	Overall length mm	⚖	📦/📦
302102	PH2	50	34	20 / 400
302103	PH3	50	34	20 / 400
302104	PH4	50	34	20 / 400

3022



- Slotted head
- DIN ISO 8764-1



KT NO.	Tip width mm	Tip thickness mm	Overall length mm	⚖	📦/📦
302205	5	1.0	50	34	20 / 400
302208	8	1.2	50	38	20 / 400
302210	10	1.6	50	46	20 / 400

3025



- Hexagon head
- DIN 7422 / 3120



KT NO.	mm	Overall length mm	⚖	📦/📦
302503	H3	50	30	20 / 400
302504	H4	50	34	20 / 400
302505	H5	50	35	20 / 400
302506	H6	50	35	20 / 400
302507	H7	50	39	20 / 400
302508	H8	50	41	20 / 400
302509	H9	50	44	20 / 400
302510	H10	50	50	20 / 400
302512	H12	50	53	20 / 400

3023



- For torx internal screw
- DIN 3120



KT NO.	mm	Overall length mm	⚖	📦/📦
302308	T8	50	30	20 / 400
302309	T9	50	30	20 / 400
302310	T10	50	34	20 / 400
302315	T15	50	34	20 / 400
302320	T20	50	33	20 / 400
302325	T25	50	34	20 / 400
302327	T27	50	34	20 / 400
302330	T30	50	35	20 / 400
302340	T40	50	36	20 / 400
302345	T45	50	39	20 / 400
302350	T50	50	40	20 / 400

3027



- For tamper resistant torx screw
- DIN 3120



KT NO.	mm	Overall length mm	⚖	📦/📦
302708	T8H	50	33	20 / 400
302709	T9H	50	33	20 / 400
302710	T10H	50	33	20 / 400
302715	T15H	50	34	20 / 400
302720	T20H	50	33	20 / 400
302725	T25H	50	34	20 / 400
302727	T27H	50	34	20 / 400
302730	T30H	50	35	20 / 400
302740	T40H	50	35	20 / 400
302745	T45H	50	39	20 / 400
302750	T50H	50	39	20 / 400

3039



- Ribe bit socket
- Use for VW, Audi, Fiat cylinder head bolt
- DIN 3120



KT NO.	size	Overall length mm	⚖	📦/📦
303906	M6	90	70	8 / 160
303907	M7	90	71	8 / 160
303908	M8	90	71	8 / 160
303909	M9	90	88	8 / 160
303910	M10	90	90	8 / 160

302D



- For torx plus tamper screw
- IPR20 for the operation of the screwed connection of the plug-in pump on MERCEDES-BENZ Atego and Actros MAZDA 3 1.4 and 1.6
- IPR25 for the screwed connections at the control unit and the air flow sensor on VW
- DIN 3120



KT NO.	mm	Overall length mm	⚖	📦/📦
302D08	IPR8	50	33	20 / 400
302D09	IPR9	50	33	20 / 400
302D10	IPR10	50	33	20 / 400
302D15	IPR15	50	33	20 / 400
302D20	IPR20	50	34	20 / 400
302D25	IPR25	50	34	20 / 400
302D27	IPR27	50	34	20 / 400
302D30	IPR30	50	35	20 / 400
302D40	IPR40	50	36	20 / 400
302D45	IPR45	50	38	20 / 400
302D50	IPR50	50	40	20 / 400
302D55	IPR55	50	48	20 / 400
302D60	IPR60	50	53	15 / 300

Ratchet

KT No. & D1



3725

FINE GEAR 3/8"

- Reversible ratchet
- 8° gear action degree (45 teeth)
- DIN 3122

KT NO.	Overall length			
	inch	mm		
3725-08F	8	203	369	2 / 40
3725-08G	8	207	384	2 / 32
3725DK	renewal kits		-	-



3725DK



3725-08F



3725-08G

3755

FINE GEAR 3/8"

- Reversible ratchet
- 5° gear action degree (72 teeth)
- DIN 3122

KT NO.	Overall length			
	inch	mm		
3755-08G	8	200	190	2 / 40
3755DK	renewal kits		-	-



3755DK

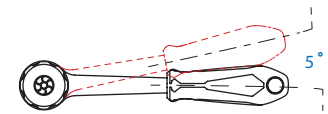

3752

QUICK RELEASE **FINE GEAR** 3/8"

- Quick release swivel reversible ratchet
- 5° gear action degree (72 teeth)
- Multi-angle design for difficult-to-reach fasteners



KT NO.	Overall length			
	inch	mm		
3752-09G	9	235	374	2 / 32
3752DK	renewal kits		-	-



3752DK

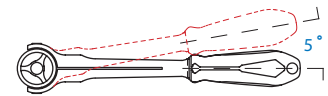

3760

MINI RATCHET **FINE GEAR** 3/8"

- Mini reversible ratchet
- 5° gear action degree (72 teeth)
- Two teeth pawl action
- DIN 3122

KT NO.	Overall length			
	inch	mm		
3760-45	4-3/8	110	116	6 / 108
3760DK01	renewal kits		-	-



3760DK01



3761

QUICK RELEASE 3/8"

- Quick release reversible ratchet
- 11° gear action degree (32 teeth)
- Two teeth pawl action
- DIN 3122

KT NO.	Overall length			
	inch	mm		
3761-08F	8	200	401	2 / 40
3761-08P	8	200	376	2 / 40
34362-2DK	renewal kits		-	-



34362-2DK



3761-08F



3761-08P



Ratchet



3769

3/8"

- Reversible ratchet
- 11° gear action degree (32 teeth)
- Two teeth pawl action
- DIN 3122

KT NO.	Overall length			
	inch	mm		
3769-08F	8	200	405	2 / 40
3769-08P	8	200	380	2 / 40
3769DK	renewal kits		-	-



3769DK



3769-08F



3769-08P

3771

QUICK RELEASE 3/8"

- Quick release reversible ratchet
- 11° gear action degree (32 teeth)
- Two teeth pawl action
- DIN 3122

KT NO.	Overall length			
	inch	mm		
3771-08G	8	200	268	2 / 40
3771DK	renewal kits		-	-



3771DK



3774

3/8"

- Universal joint reversible ratchet
- 11° gear action degree (32 teeth)
- Two teeth pawl action
- DIN 3122
- 15° rotation

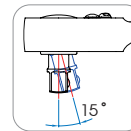

KT NO.	Overall length			
	inch	mm		
3774-08G	8	200	275	2 / 40
3774DK	renewal kits		-	-



3774DK



3779

3/8"

- Reversible ratchet
- 11° gear action degree (32 teeth)
- Two teeth pawl action
- DIN 3122

KT NO.	Overall length			
	inch	mm		
3779-08F	8	200	366	2 / 40
3779-08G	8	200	273	2 / 40
3779DK	renewal kits		-	-



3779DK



3779-08F



3779-08G

3781

QUICK RELEASE 3/8"

- Quick release flexible and reversible ratchet
- 11° gear action degree (32 teeth)
- Two teeth pawl action
- DIN 3122

KT NO.	Overall length			
	inch	mm		
3781-11F	11	280	467	2 / 40
3781-11P	11	280	445	2 / 40
3781DK	renewal kits		-	-

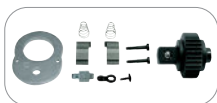

3781DK



3781-11F



3781-11P

- Material - chrome vanadium alloy steel
- Finishing - polished, chrome plated & black phosphate sunk

Accessory

KT No. & D1

3221 3/8"

- Extension bar
- DIN 3123



KT NO.	Overall length		Scales	Crate/Box
	inch	mm		
3221-16	1-3/4	44	47	12 / 360
3221-03	3	75	77	12 / 240
3221-06	6	150	146	6 / 120
3221-10	10	250	238	6 / 96
3221-18	18	450	324	1 / 50
3221-24	24	600	424	1 / 50

3223 3/8"

- Offset extension bar, wobble extension bar
- Max. torque : 150 N-m
- DIN 3123



CAUTION The offset extension bar has less strength than normal extension bar. Do not use as a normal extension bar.



KT NO.	Overall length		Scales	Crate/Box
	inch	mm		
3223-14	1-1/2	38	40	14 / 224
3223-02	2	50	52	12 / 360
3223-03	3	75	75	12 / 240
3223-06	6	150	144	6 / 120
3223-10	10	250	237	6 / 96

3293 3/8"

- Multi-function of extension bar and offset extension bar, wobble extension bar
- Max. torque : 150 N-m

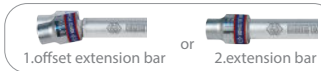

KT NO.	Overall length		Scales	Crate/Box
	inch	mm		
3293-03	3	75	75	12 / 240
3293-06	6	150	143	6 / 120
3293-10	10	250	228	6 / 96

3311 3/8"

- Flexible extension bar
- DIN 3120



KT NO.	Overall length		Scales	Crate/Box
	inch	mm		
3311-06	6	150	144	5 / 100
3311-12	12	300	168	12 / 108

3893EW 1/4" & 3/8"

- Extension wrench
- Length extension drive bar enables easier works in confined spaces
- Provided with two square drive adapters in 1/4" and 3/8"
- Chain-driven mechanism enhances working durability and smoothness
- Max torque allowed: 130 N m / 96 ft lb



3/8"
3893EW-01



1/4"
3893EW-02



KT NO.	Drive	Overall length		Capacity	Scales	Crate/Box
		inch	mm			
3893EW		13.4	340	300	410	20 / 40
3893EW-01	3/8"	-	-		20	10 / 160
3893EW-02	1/4"	-	-		20	10 / 160

3452 3/8"

- Flexible handle
- Action degree -180°
- DIN 3122



3452DK



KT NO.	Overall length		Scales	Crate/Box
	inch	mm		
3452-08F	8	205	291	4 / 80
3452-10F	10	250	310	4 / 64
3452DK	renewal kits		-	-

3453 3/8"

- Flexible handle
- Action degree -180°
- New pattern design added in firm and powerful elements
- New forge technologies I-Beam shank offers 15% lightweight
- DIN 3122



3453DK

KT NO.	Overall length		Scales	Crate/Box
	inch	mm		
3453-08F	8	200	221	4 / 80
3453DK	renewal kits			

3571 3/8"

- Sliding T-handle
- DIN 3122



KT NO.	Overall length		Scales	Crate/Box
	inch	mm		
3571-08	8	200	178	4 / 80

Accessory

KT No. & DT

3792 3/8"

- Universal joint
- DIN 3123



KT NO.	Overall length inch	mm		
3792	2	50	67	15 / 300

3794 3/8"

- Universal joint
- 30° rotation
- Short pattern design enables greater access in confined spaces

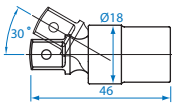

KT NO.	Overall length inch	mm		
3794	1-4/5	46	106	15 / 300

9113PR 1/4" 3/8" 1/2"

- Universal joint
- Ball point type universal joint & with hex locking design
- Short pattern design enables greater access in confined spaces



3 PC.

Contents 0.20 6 / 108

	2793	31mm
	3793	43mm
	4793	59mm

3812 3814 3/8"

- Adapter
- Convert to 1/4" drive or 1/2" drive
- 3812 → Max. torque : 62 N·m
- DIN 3123, ISO 3316

1/4" drive (M) 3/8" drive (F)
1/2" drive (M)



3812 / 3814

KT NO.	Spec.		
3812	3/8"Fx1/4"M	30	12 / 192
3814	3/8"Fx1/2"M	46	12 / 360

3148 3/8"

- Bit holder
- DIN 3120 / 3126



KT NO.	Size	Overall length mm		
314808S	1/4"	30	35	12 / 360
314810S	5/16"	30	35	12 / 360
314810M	10 mm	30	35	12 / 360

Socket Rail Set

3013MR 3013SR

3513MR 3/8"

- Socket rail 290mmL



13 PC.

KT NO.	Contents	0.52	4 / 24
3013MR	3330M	7, 8, 9, 10, 11, 12, 13, 14, 15, 16, 17, 18, 19	8731213
3013SR	3330S	1/4, 5/16, 11/32, 3/8, 7/16, 15/32, 1/2, 9/16, 19/32, 5/8, 11/16, 3/4, 13/16	
3513MR	3335M	7, 8, 9, 10, 11, 12, 13, 14, 15, 16, 17, 18, 19	

3508MR10 3/8"

- Socket rail 210mmL



8 PC.

Contents	0.65	2 / 24
3235M	10, 11, 12, 13, 14, 16, 17, 19	8730808
8730808		

3106PR 3/8"

- Socket rail 150mmL



6 PC.

Contents	0.28	4 / 48
3375M	E8, E10, E12, E14, E16, E18	8730606
8730606		

3116PR 3/8"

- Socket rail 150mmL



6 PC.

Contents	0.39	4 / 32
3275M	E4, E5, E8, E10, E12, E14	8730606
8730606		

3129PR 3/8"

- Socket rail 210mmL



9 PC.

Contents	0.27	4 / 32
3375M	E4, E5, E6, E7, E8, E10, E12, E14, E16	8730809
8730809		

Socket Rail Set

Packing

3109PR8 / 3119PR8 / 3149PR8 / 3131PR8



3121PR

3/8"

- Socket rail 290mmL

11 PC.



Contents

0.32 4 / 24



3375M E4, E5, E6, E7, E8, E10, E11, E12, E14, E16, E18

8731213

3E07PR

3/8"

- Socket rail 210mmL

7 PC.



Contents

0.42 4 / 32



333E

EP10, EP11, EP12, EP14, EP16, EP18, EP20

8730808

3108PR8

3/8"

- Socket rail 210mmL
- For hex head screw
- H : 50mm

8 PC.



Contents

0.34 50



3025

H3, H4, H5, H6, H7, H8 H10, H12

8730808

3109PR8

3/8"

- Socket rail 210mmL
- For torx head screw
- H : 50mm

9 PC.



Contents

0.36 50



3023

T10, T15, T20, T25, T27, T30, T40, T45, T50

8730809

3119PR8

3/8"

- Socket rail 210mmL
- For tamper resistant torx head screw
- H : 50mm

9 PC.



Contents

0.36 50



3027

T10H, T15H, T20H, T25H, T27H, T30H, T40H, T45H, T50H

8730809

3131PR8

3/8"

- Socket rail 210mmL
- For tamper resistant torx head screw
- H : 50mm

11 PC.



Contents

0.4 48



3027

T8H, T9H, T10H, T15H, T20H, T25H, T27H, T30H, T40H, T45H, T50H

8730811

3146PR

3/8"

- Socket rail 150mmL
- For torx plus tamper resistant head screw
- H : 50mm

6 PC.



Contents

0.36 4 / 32



302D

IPR10, IPR15, IPR20, IPR25, IPR27, IPR30

8730606

3149PR8

3/8"

- Socket rail 210mmL
- For torx plus tamper resistant head screw
- H : 50mm

9 PC.



Contents

0.36 50



302D

IPR10, IPR15, IPR20, IPR25, IPR27, IPR30, IPR40, IPR45, IPR50

8730809

3105PR

3/8"

- 3/8" + 1/2" drive ribe bit socket set
- Socket rail 150mmL
- For ribe head screw
- H : 100mm

5 PC.



Contents

0.75 4 / 32



3039

M7, M8



4049

M10, M12, M13

8740606



Socket Rail

873

3/8"

- Rail length from 160 mm to 560 mm



KT NO.		L (mm)
870406		160
870311		280
870422		560
8730		-

8730811D1

3/8"

- Socket rail carrier with retaining clip
- 446mm roller cabinet



KT NO.	Square drive	Clip	L (mm)
8730811D1	3/8"	11	508

Extension Bar Set

3113PR

3/8"

3 PC.



Contents

0.5 35

3221 3", 6", 10"

3103PR

3/8"

3 PC.



Contents

0.4 35

3223 3", 6", 10"

Socket Set

3213MR

3/8"

Contents

0.79 1 / 24

3330M 8, 9, 10, 11, 12, 13, 14, 15, 16, 17, 19

3755-08G 3221-06



13 PC.

3508MR

3/8"

Metal case size (mm):
203 x 79 x 41 (0.023 cuft)



Contents

1.0 1 / 20

3235M 10, 11, 12, 13, 14, 16, 17, 19

3508SR

3/8"

Metal case size (mm):
203 x 79 x 41 (0.023 cuft)



8 PC.

Contents

1.0 1 / 20

3235S 3/8, 7/16, 1/2, 9/16, 5/8, 11/16, 3/4, 13/16

Socket Set

3020MR

3020SR

3020MR02

3020SR02

3520MR

3520MR02

3/8"

Metal case size (mm) :
372 x 153 x 40 (0.08 cuft)









3020MR / 3520MR



3020SR

20
PC.



KT NO.	Contents		kg	1/6
3020MR	 3330M	6, 7, 8, 9, 10, 11, 12, 13, 14, 17, 19, 21, 22	 363021	1 / 6
3020MR02				
3020SR	 3330S	1/4, 5/16, 11/32, 3/8, 7/16, 15/32, 1/2, 9/16, 19/32, 11/16, 3/4, 13/16, 7/8	 363521	1 / 6
3020SR02				
3520MR	 3335M	6, 7, 8, 9, 10, 11, 12, 13, 14, 17, 19, 21, 23	 363521	1 / 6
3520MR02				

3023MR

3523MR

3/8"

Metal case size (mm) :
372 x 153 x 40 (0.08 cuft)

KT NO.	Contents		kg	1/6
3023MR	 3330M	6, 7, 8, 9, 10, 11, 12, 13, 14, 15, 16, 17, 19, 20, 21, 22	 3769-08F	1 / 6
3523MR				



22
PC.





3024MR

3024SR

3524MR

3/8"

Metal case size (mm) :
318 x 147 x 46 (0.076 cuft)

KT NO.	Contents		kg	1 / 10
3024MR	 3330M	6, 7, 8, 9, 10, 11, 13, 14, 17, 19	 3021 PH2, PH3	1 / 10
3524MR				
3024SR	 3330S	1/4, 5/16, 11/32, 3/8, 7/16, 1/2, 9/16, 5/8, 11/16, 3/4	 3779-08G  3792	1 / 10



3024MR/3524MR

24
PC.



3024SR

Socket Set









3027MR

3027SR

3527MR

3/8"

Metal case size (mm) :
318 x 147 x 46 (0.076 cuft)

KT NO.	Contents		Kg 2.6	1 / 10
3027MR	 3330M	7, 8, 9, 10, 11, 12, 13, 14, 15, 16, 17, 18, 19	 3235M	
3527MR	 3335M			
3027SR	 3330S	1/4, 5/16, 11/32, 3/8, 7/16, 15/32, 1/2, 9/16, 19/32, 5/8, 11/16, 3/4, 13/16		
	 3235S			



3027MR/3527MR



3027SR







26 PC.

3034MR

3534MR

3/8"

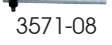
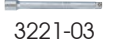
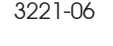
Metal case size (mm) :
372 x 153 x 40 (0.08 cuft)

KT NO.	Contents		Kg 3.1	1 / 6
3034MR	 3330M	6, 7, 8, 9, 10, 11, 13, 14, 17, 19	 3375M	
3534MR	 3335M			
			E4, E5, E6, E7, E8, E10, E12, E14, E16, E18	
			T8, T9, T10, T15, T20, T25, T27, T30, T40, T45	
				
				
				









36 PC.

3036CR

3/8"

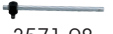
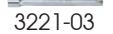
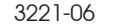
Metal case size (mm) :
372 x 153 x 40 (0.08 cuft)

Contents		Kg 3.27	1 / 6
 3330M	6, 7, 8, 9, 10, 11, 12, 13, 14, 15, 16, 17, 19, 20, 21, 22		
 3330S	1/4, 5/16, 11/32, 3/8, 7/16, 15/32, 1/2, 9/16, 19/32, 5/8, 11/16, 3/4, 13/16, 7/8		
			
			









36 PC.

3537MR

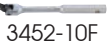
3/8"

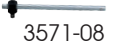
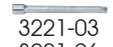
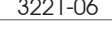
Metal case size (mm) :
372 x 153 x 40 (0.08 cuft)

Contents		Kg 3.17	1 / 6
 3023	T8, T9, T10, T15, T20, T25, T27, T30, T40, T45		
 3335M	6, 7, 8, 9, 10, 11, 12, 13, 14, 15, 17, 18, 19		
 3375M	E4, E5, E6, E7, E8, E10, E12, E14, E16, E18		
			
			





















39 PC.

Socket Set

3055CR

3/8"

Metal case size (mm) :
490 x 205 x 52 (0.185 cuft)

Contents		6	1 / 3
	 3330M	6, 7, 8, 9, 10, 11, 12, 13, 14, 15, 16, 17, 18, 19, 20, 21, 22	
	 3230M	10, 11, 12, 13, 14, 15, 16, 17, 18, 19	
	 3330S	1/4, 5/16, 3/8, 7/16, 1/2, 9/16, 5/8, 11/16, 3/4, 13/16, 7/8	
	 3230S	1/4, 5/16, 3/8, 7/16, 1/2, 9/16, 5/8, 11/16, 3/4	
	 363516	 363521	 3792
	 3771-08G	 3452-10F	
	 3293-06	 3221-03	 3221-10













55 PC.

3523MRV10

Tray category #10 (375 x 140mm) 3/8"

Plastic case size (mm) :
389 x 185 x 66 (0.168 Cuft)

Contents		2.43	1 / 10
	 3335M	6, 7, 8, 9, 10, 11, 12, 13, 14, 15, 16, 17, 19, 21, 22, 23, 24	
	 3771-08G	 3792	
	 3571-08	 3452-08F	
	 3293-03	 3293-06	



23 PC.

3023MRV11

Plastic case size (mm) :
389 x 185 x 66 (0.168 Cuft)

3523MRV11

Tray category #10 (375 x 140mm) 3/8"

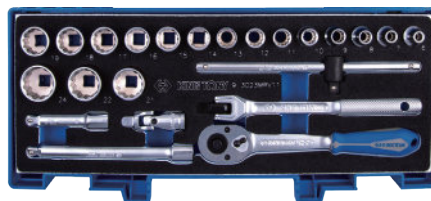



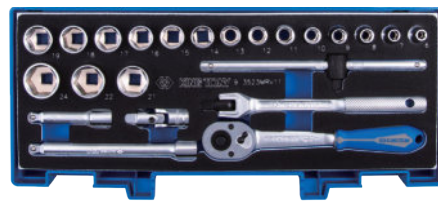



3023MRV11



3523MRV11

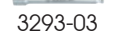









23 PC.

KT NO.	Contents	2.40	1 / 10
3023MRV11	 3330M	6, 7, 8, 9, 10, 11, 12, 13, 14, 15, 16, 17, 18, 19, 21, 22, 24	 3771-08G
3523MRV11	 3335M	6, 7, 8, 9, 10, 11, 12, 13, 14, 15, 16, 17, 18, 19, 21, 22, 24	 3453-08F  3571-08  3293-03  3293-06  3792

3032SRV

Tray category #8 (375 x 187mm) 3/8"

Plastic case size (mm) :
389 x 230 x 66 (0.168 Cuft)

Contents		3.28	1 / 6
	 3230S	5/16, 3/8, 7/16, 15/32, 1/2, 9/16, 19/32, 5/8, 11/16, 3/4, 13/16, 7/8	
	 3330S	1/4, 5/16, 11/32, 3/8, 7/16, 15/32, 1/2, 9/16, 19/32, 5/8, 11/16, 3/4, 13/16, 7/8, 15/16	
	 3771-08G	 3453-08F	
	 3293-03	 3293-06	 3792

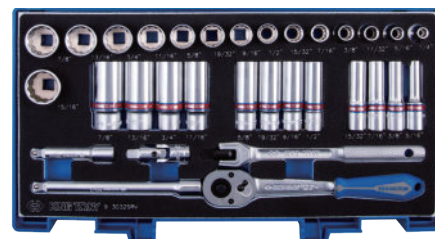

32 PC.

Socket Set

3033MRV

Plastic case size (mm) :
389 x 230 x 66 (0.168 Cuft)

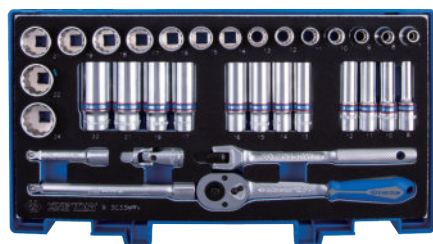

3033MRV

3533MRV

Tray category #8 (375 x 187mm) 3/8"

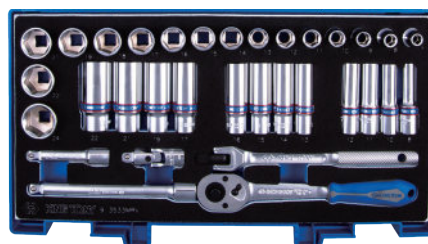

3533MRV

33
PC.

KT NO.	Contents		
3033MRV	3330M	7, 8, 9, 10, 11, 12, 13, 14, 15, 16, 17, 18, 19, 21, 22, 24	3771-08G 3792
	3230M	8, 10, 11, 12, 13, 14, 15, 16, 17, 19, 21, 22	
3533MRV	3335M	7, 8, 9, 10, 11, 12, 13, 14, 15, 16, 17, 18, 19, 21, 22, 24	3453-08F 3293-03 3293-06
	3235M	8, 10, 11, 12, 13, 14, 15, 16, 17, 19, 21, 22	

3.40 1 / 6

3545MRV

Tray category #8 (375 x 187mm) 3/8"

Plastic case size (mm) :
389 x 230 x 66 (0.168 Cuft)

Contents		
3335M	6, 7, 8, 9, 10, 11, 12, 13, 14, 15, 16, 17, 18, 19, 21, 22, 24	2.47 1 / 6
3375M	E4, E5, E6, E7, E8, E10, E11, E12, E14, E16, E18	
3023	T8, T9, T10, T15, T20, T25, T27, T30, T40, T45, T50	
3771-08G	3453-08F	
3571-08	3792 3293-03 3293-06	

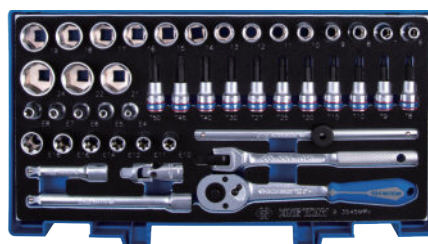

45
PC.

3054MR

3/8"

Blow case size (mm) :
340 x 263 x 80 (0.25cuft)

Contents		
3330M	6, 7, 8, 9, 10, 11, 12, 13, 14, 15, 17, 18, 19, 21, 22	3.85 1 / 3
3235M	8, 10, 12, 13, 14	
1025T	T10, T15, T20, T25, T30, T40, T45 T50	
3630	16, 21	
1145MR	H1.5, H2, H2.5, H3, H4, H5, H6, H8, H10	
14A1	PH2 x 100	
14A2	5.5 x 100	
1060	8, 10, 12, 13, 14, 17, 19	
3771-08G	3792 3221-03 3221-06	
31480S	6111-06	



54
PC.

Socket Set





3568MR

3/8"

Metal shelf size (mm) :
415 x 336 x 320 (1.58 cuft)



268
PC.

Contents		Each Q'ty	
○ 	 3335M	8, 9, 10, 11, 12, 13	10
		14, 15, 16, 17, 18, 19	8
		21, 22, 23, 24	6
○ 	 3235M	7, 8, 9, 10, 11, 12, 13	10
		14, 15, 16, 17, 18, 19	8
		21, 22, 24	6



KT NO.	Spec.		Cuft
3568MR-A	87102	6.35	0.67
3568MR-D	268 PC. socket content	16.50	0.38



Standard Socket

4330MR

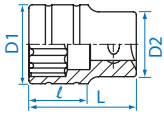

4330SR 1/2"



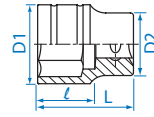

4335MR







4335SR 1/2"



KT NO.	mm	D1 mm	D2 mm	ℓ mm	L mm		
433008MR	8	13.2	23.3	7.0	38	53	10 / 200
433009MR	9	14.0	23.3	7.0	38	52	10 / 200
433010MR	10	15.0	23.3	8.0	38	51	10 / 200
433011MR	11	16.4	23.3	8.0	38	54	10 / 200
433012MR	12	17.8	23.3	9.0	38	54	10 / 200
433013MR	13	19.0	23.3	10.0	38	58	10 / 200
433014MR	14	20.4	23.3	11.0	38	60	10 / 200
433015MR	15	21.6	23.3	11.0	38	61	10 / 200
433016MR	16	22.5	23.3	11.0	38	61	10 / 200
433017MR	17	24.0	23.2	12.0	38	62	10 / 200
433018MR	18	25.2	23.2	13.0	38	69	10 / 200
433019MR	19	27.0	23.2	13.0	38	72	10 / 160
433020MR	20	27.9	23.2	13.0	38	74	10 / 160
433021MR	21	28.9	23.2	14.0	38	78	10 / 160
433022MR	22	30.2	24.0	15.0	40	90	10 / 160
433023MR	23	31.2	25.0	15.0	40	92	8 / 160
433024MR	24	32.1	26.0	17.0	42	101	8 / 160
433025MR	25	33.4	27.0	17.0	42	107	8 / 160
433026MR	26	35.0	28.0	17.0	42	125	6 / 120
433027MR	27	36.6	28.0	19.0	42	130	6 / 120
433028MR	28	37.8	30.0	20.0	42	142	6 / 120
433029MR	29	39.0	30.0	21.0	44	161	6 / 120
433030MR	30	40.0	29.5	21.0	44	156	6 / 120
433032MR	32	42.5	30.0	23.0	44	163	6 / 120
433033MR	33	43.0	30.0	24.0	46	173	6 / 96
433034MR	34	45.0	30.0	24.0	46	207	6 / 96
433036MR	36	47.0	33.0	24.0	46	236	6 / 96

KT NO.	inch	D1 mm	D2 mm	ℓ mm	L mm		
433010SR	5/16	13.2	21.8	7.0	38	41	10 / 200
433012SR	3/8	15.0	21.8	7.0	38	44	10 / 200
433013SR	13/32	15.0	23.3	7.0	38	51	10 / 200
433014SR	7/16	16.4	23.3	8.0	38	53	10 / 200
433015SR	15/32	18.0	23.3	8.0	38	55	10 / 200
433016SR	1/2	19.0	23.3	10.0	38	57	10 / 200
433018SR	9/16	20.4	23.3	11.0	38	59	10 / 200
433019SR	19/32	21.6	23.3	11.0	38	60	10 / 200
433020SR	5/8	22.5	23.3	11.0	38	62	10 / 200
433022SR	11/16	24.0	23.2	12.0	38	60	10 / 200
433024SR	3/4	27.0	23.2	13.0	38	73	10 / 160
433025SR	25/32	28.0	23.2	13.0	38	75	10 / 160
433026SR	13/16	28.6	23.2	13.0	38	79	10 / 160
433028SR	7/8	30.2	24.0	15.0	40	87	10 / 160
433030SR	15/16	32.6	26.0	17.0	42	105	8 / 160
433032SR	1	34.8	26.8	17.0	42	119	8 / 160
433034SR	1-1/16	36.6	28.0	19.0	42	133	6 / 120
433036SR	1-1/8	39.0	30.0	21.0	44	158	6 / 120
433038SR	1-3/16	40.0	29.5	21.0	44	156	6 / 120
433040SR	1-1/4	42.5	30.0	23.0	44	173	6 / 120
433044SR	1-3/8	46.0	33.0	24.0	46	243	6 / 96

KT NO.	mm	D1 mm	D2 mm	ℓ mm	L mm		
433506MR	6	12.0	23.3	7.0	38	51	10 / 200
433507MR	7	12.6	23.3	7.0	38	51	10 / 200
433508MR	8	13.2	23.3	7.0	38	52	10 / 200
433509MR	9	14.0	23.3	7.0	38	51	10 / 200
433510MR	10	15.0	23.3	8.0	38	51	10 / 200
433511MR	11	16.4	23.3	8.0	38	54	10 / 200
433512MR	12	17.8	23.3	9.0	38	56	10 / 200
433513MR	13	19.0	23.3	10.0	38	58	10 / 200
433514MR	14	20.4	23.3	11.0	38	61	10 / 200
433515MR	15	21.6	23.3	11.0	38	62	10 / 200
433516MR	16	22.5	23.3	11.0	38	63	10 / 200
433517MR	17	24.0	23.2	13.5	38	63	10 / 200
433518MR	18	25.2	23.2	13.5	38	66	10 / 200
433519MR	19	27.0	23.2	17.0	38	74	10 / 160
433520MR	20	27.9	23.2	17.0	38	76	10 / 160
433521MR	21	28.9	23.2	17.0	38	79	10 / 160
433522MR	22	30.2	24.0	17.0	38	90	10 / 160
433523MR	23	31.2	25.0	17.0	38	99	8 / 160
433524MR	24	32.1	26.0	17.0	38	108	8 / 160
433525MR	25	33.4	27.0	18.0	40	118	8 / 160
433526MR	26	35.0	28.0	21.0	42	130	6 / 120
433527MR	27	36.6	28.0	21.0	42	141	6 / 120
433528MR	28	37.8	30.0	20.0	42	154	6 / 120
433529MR	29	39.0	30.0	20.0	44	165	6 / 120
433530MR	30	40.0	29.5	22.0	44	164	6 / 120
433532MR	32	42.5	30.0	22.0	44	180	6 / 120
433533MR	33	43.0	30.0	24.0	46	185	6 / 96
433534MR	34	45.0	30.0	24.0	46	206	6 / 96
433536MR	36	47.0	33.0	24.0	46	251	6 / 96
433538MR	38	49.0	34.0	25.0	50	268	6 / 60
433539MR	39	50.0	34.0	25.0	50	291	6 / 60
433541MR	41	53.0	36.0	27.0	53	336	6 / 36
433546MR	46	59.0	40.0	30.0	58	453	4 / 32

KT NO.	inch	D1 mm	D2 mm	ℓ mm	L mm		
433510SR	5/16	13.2	21.8	7.0	38	44	10 / 200
433512SR	3/8	15.0	21.8	7.0	38	45	10 / 200
433514SR	7/16	16.4	23.3	8.0	38	54	10 / 200
433515SR	15/32	18.0	23.3	8.0	38	56	10 / 200
433516SR	1/2	19.0	23.3	10.0	38	58	10 / 200
433518SR	9/16	20.4	23.3	11.0	38	59	10 / 200
433519SR	19/32	21.6	23.3	11.0	38	61	10 / 200
433520SR	5/8	22.5	23.3	11.0	38	62	10 / 200
433522SR	11/16	24.0	23.2	12.0	38	62	10 / 200
433524SR	3/4	27.0	23.2	13.0	38	75	10 / 160
433525SR	25/32	28.0	23.2	13.0	38	77	10 / 160
433526SR	13/16	28.6	23.2	13.0	38	80	10 / 160
433528SR	7/8	30.2	24.0	15.0	40	92	10 / 160
433530SR	15/16	32.6	26.0	17.0	42	113	8 / 160
433532SR	1	34.8	26.8	17.0	42	124	8 / 160
433534SR	1-1/16	36.6	28.0	19.0	42	138	6 / 120
433536SR	1-1/8	39.0	30.0	21.0	44	166	6 / 120
433538SR	1-3/16	40.0	29.5	21.0	44	168	6 / 120
433540SR	1-1/4	42.5	30.0	23.0	44	176	6 / 120

Socket Set

4072MR

4072SR

4572MR

4572SR

1/2"

Metal shelf size (mm) :
415x 336 x 320 (1.58 cuft)



4072MR / 4572MR

KT NO.	PC.		Contents	Each Q'ty	
4072MR	172		4330MR	8, 9, 10, 11, 12, 13, 14, 15, 16, 17, 18	8
				19, 20, 21, 22, 23, 24, 25	7
4572MR	172		4335MR	26, 27, 28, 29, 30,	6
				32	5
4072SR	136		4330SR	5/16, 3/8, 7/16, 15/32, 1/2, 9/16, 19/32, 5/8, 11/16	8
				3/4, 25/32, 13/16, 7/8, 15/16	7
4572SR	136		4335SR	1, 1-1/16, 1-1/8, 1-3/16	6
				1-1/4	5

KT NO.	Spec.		Cuft
4072MR -A 4572MR	87103	6.37	0.67
4072MR -D 4572MR	172 PC. socket content	17.73	0.38
4072SR -A 4572SR	87103	6.37	0.67
4072SR -D 4572SR	136 PC. socket content	13.00	0.28

Deep Socket

4230M

4230S 1/2"

- Metric-DIN 3124, ISO 2725-1
- Inch-ANSI / ASME B107.1

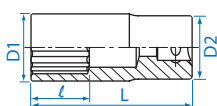

KT NO.	mm	D1 mm	D2 mm	l mm	L mm		
423008M	8	13.2	22.0	16	77	79	6 / 120
423009M	9	14.0	22.0	16	77	79	6 / 120
423010M	10	15.2	23.7	24	77	99	6 / 120
423011M	11	16.3	23.7	24	77	104	6 / 120
423012M	12	17.7	23.7	24	77	110	6 / 120
423013M	13	18.7	23.7	24	77	114	6 / 120
423014M	14	20.2	23.7	35	77	121	6 / 120
423015M	15	21.3	23.7	35	77	120	6 / 120
423016M	16	22.6	23.7	35	77	128	6 / 96
423017M	17	23.7	23.2	35	77	122	6 / 96
423018M	18	25.5	23.2	35	77	141	6 / 96
423019M	19	25.7	23.2	35	77	126	6 / 96
423020M	20	27.7	24.0	35	77	150	6 / 96
423021M	21	27.7	25.0	35	77	148	6 / 96
423022M	22	29.8	26.0	35	77	175	6 / 96

KT NO.	mm	D1 mm	D2 mm	l mm	L mm		
423023M	23	31.8	27.5	35	77	210	5 / 60
423024M	24	31.8	28.5	35	77	204	5 / 60
423025M	25	33.8	29.5	35	77	239	5 / 60
423026M	26	35.8	30.5	35	77	220	5 / 60
423027M	27	35.8	31.5	34	77	253	5 / 60
423028M	28	37.8	32.5	34	77	308	5 / 50
423029M	29	37.8	33.5	34	77	273	5 / 50
423030M	30	39.8	34.5	34	77	276	5 / 50
423032M	32	41.8	36.0	34	77	309	5 / 50
423033M	33	43.8	38.5	35	77	356	5 / 50
423034M	34	44.8	38.5	35	77	422	5 / 50
423036M	36	46.8	40.5	36	77	462	2 / 40

KT NO.	inch	D1 mm	D2 mm	l mm	L mm		
423010S	5/16	13.2	22.0	9	77	92	6 / 120
423012S	3/8	14.7	22.0	10	77	82	6 / 120
423014S	7/16	16.3	23.7	12	77	98	6 / 120
423016S	1/2	18.7	23.7	14	77	114	6 / 120
423018S	9/16	20.2	23.7	15	77	119	6 / 120
423020S	5/8	22.6	23.7	17	77	129	6 / 96
423022S	11/16	23.7	23.2	35	77	124	6 / 96
423024S	3/4	25.7	23.2	35	77	128	6 / 96
423026S	13/16	27.7	25.0	37	77	151	6 / 96
423028S	7/8	29.8	26.0	37	77	170	6 / 96
423030S	15/16	31.8	28.5	37	77	208	5 / 60
423032S	1	33.8	29.5	37	77	233	5 / 60
423034S	1-1/16	36.6	31.5	28	77	247	5 / 60
423036S	1-1/8	37.8	32.5	28	77	254	5 / 50
423038S	1-3/16	39.8	34.5	34	77	285	5 / 50
423040S	1-1/4	41.8	36.0	34	77	305	5 / 50

Deep Socket

KT No. & D1



4235M

4235S \bigcirc 1/2"

- Metric-DIN 3124, ISO 2725-1
- ANSI / ASME B107.1

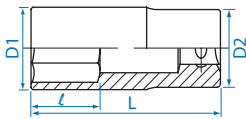

KT NO.	\bigcirc mm	D1 mm	D2 mm	l mm	L mm		
423508M	8	13.2	22.0	16	77	90	6 / 120
423509M	9	14.0	22.0	16	77	81	6 / 120
423510M	10	15.2	23.7	24	77	102	6 / 120
423511M	11	16.3	23.7	24	77	103	6 / 120
423512M	12	17.7	23.7	24	77	113	6 / 120
423513M	13	18.7	23.7	24	77	119	6 / 120
423514M	14	20.2	23.7	35	77	121	6 / 120
423515M	15	21.3	23.7	35	77	126	6 / 120
423516M	16	22.6	23.7	35	77	130	6 / 96
423517M	17	23.7	23.2	35	77	127	6 / 96
423518M	18	25.5	23.2	35	77	149	6 / 96
423519M	19	25.7	23.2	35	77	133	6 / 96
423520M	20	27.7	24.0	35	77	158	6 / 96
423521M	21	27.7	25.0	35	77	155	6 / 96
423522M	22	29.8	26.0	35	77	185	6 / 96
423523M	23	31.8	27.5	35	77	218	5 / 60
423524M	24	31.8	28.5	35	77	211	5 / 60
423525M	25	33.8	29.5	35	77	251	5 / 60
423526M	26	35.8	30.5	35	77	236	5 / 60
423527M	27	35.8	31.5	34	77	295	5 / 60
423528M	28	37.8	32.5	34	77	281	5 / 50
423529M	29	37.8	33.5	34	77	292	5 / 50
423530M	30	39.8	34.5	34	77	301	5 / 50
423532M	32	41.8	36.0	34	77	330	5 / 50
423533M	33	43.8	38.5	35	77	373	5 / 50
423534M	34	44.8	38.5	35	77	478	5 / 50
423536M	36	46.8	40.5	36	77	478	2 / 40
423538M	38	49.0	40.5	38	77	504	2 / 40
423541M	41	53.0	40.5	40	77	521	2 / 24

KT NO.	\bigcirc inch	D1 mm	D2 mm	l mm	L mm		
423510S	5/16	13.2	22.0	16	77	90	6 / 120
423512S	3/8	14.7	22.0	16	77	84	6 / 120
423514S	7/16	16.3	23.7	24	77	104	6 / 120
423516S	1/2	18.7	23.7	24	77	116	6 / 120
423518S	9/16	20.2	23.7	35	77	123	6 / 120
423520S	5/8	22.6	23.7	35	77	130	6 / 96
423522S	11/16	23.7	23.2	35	77	124	6 / 96
423524S	3/4	25.7	23.2	35	77	131	6 / 96
423526S	13/16	27.7	25.0	35	77	157	6 / 96
423528S	7/8	29.8	26.0	35	77	181	6 / 96
423530S	15/16	31.8	28.5	35	77	218	5 / 60
423532S	1	33.8	29.5	35	77	223	5 / 60
423534S	1-1/16	36.6	31.5	34	77	266	5 / 60
423536S	1-1/8	37.8	32.5	34	77	262	5 / 50
423538S	1-3/16	39.8	34.5	34	77	296	5 / 50
423540S	1-1/4	41.8	36.0	34	77	327	5 / 50
423542S	1-5/16	44.0	38.5	35	77	430	5 / 50
423544S	1-3/8	46.0	38.5	35	77	452	2 / 40
423546S	1-7/16	47.5	40.5	36	77	485	2 / 40
423548S	1-1/2	49.0	40.5	38	77	507	2 / 40

4245M

EXTENDED LENGTH \bigcirc 1/2"

- DIN 3120

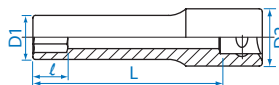

KT NO.	\bigcirc mm	D1 mm	D2 mm	l mm	L mm		
424508M	8	13.2	22.0	9.0	90	104	6 / 120
424509M	9	14.0	22.0	10.0	90	106	6 / 120
424510M	10	15.2	23.7	11.0	90	130	6 / 120
424512M	12	17.7	23.7	13.0	90	152	6 / 120
424513M	13	18.7	23.7	14.0	90	151	6 / 120
424514M	14	20.2	23.7	15.0	90	159	6 / 120

4255M

EXTENDED LENGTH \bigcirc 1/2"

- DIN 3120

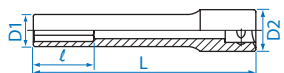

KT NO.	\bigcirc mm	D1 mm	D2 mm	l mm	L mm		
425508M	8	13.2	22.0	9	120	127	6 / 96
425509M	9	14.0	22.0	10	120	134	6 / 96
425510M	10	15.2	23.7	11	120	160	6 / 96
425512M	12	17.7	23.7	13	120	195	6 / 96
425513M	13	18.7	23.7	14	120	201	6 / 96
425514M	14	20.2	23.7	15	120	202	6 / 96

Square Socket

4014M

\blacksquare 1/2"

- DIN 3120

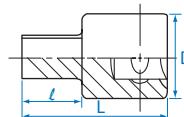

KT NO.	\blacksquare mm	\blacksquare inch	D mm	l mm	L mm		
401408M	RB8.0		23.5	13.5	35	54	10 / 200
401409M	RB9.5	3/8	23.5	13.5	35	58	10 / 200
401410M	RB10.0		23.5	13.5	35	57	10 / 200
401411M	RB10.5		23.5	13.5	35	58	10 / 200
401412M	RB12.0		23.5	13.5	35	62	10 / 200
401413M	RB12.7	1/2	23.5	13.5	35	64	10 / 200
401414M	RB13.5		23.5	13.5	35	67	10 / 200
401419M	RB19.0		25.0	15.5	40	108	10 / 160

Deep Socket Set

4066MR

4066SR

4566MR

1/2"

Metal shelf size (mm) :
415x 336 x 320 (1.58 cuff)



4066MR / 4566MR

KT NO.	PC.	Contents	Each Q'ty	KT NO.	Spec.	⚖️	Cuff	
4066MR	165	4230M 8, 9, 10, 11, 12, 13, 14, 15, 16, 17, 18 19, 20, 21, 22, 23, 24	8 7	4066MR-A 4566MR	87103	5.87	0.62	
4566MR	165	4235M 26, 27, 28, 29, 30 32	6 5	4066MR-D 4566MR	165 PC. socket content	30.70	0.63	
4066SR	114	4230S	5/16, 3/8, 7/16, 1/2, 9/16, 5/8, 11/16	8	4066SR -A	87103	5.87	0.62
			3/4, 13/16, 7/8, 15/16, 1	7				
			1-1/16, 1-1/8, 1-3/16	6				
			1-1/4	5				
4066SR -D	114 PC. socket content	21.0	0.47					

Star Socket

4375M

1/2"

- For torx external screw
- Chrome vanadium steel
- Polished, chrome plated
- DIN 3120

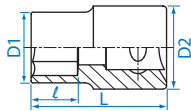

KT NO.	mm	D1 mm	D2 mm	ℓ mm	L mm	⚖️	📦
437508M	E08	11.4	23.8	7.0	37	52	10 / 200
437510M	E10	13.2	23.8	7.5	37	55	10 / 200
437511M	E11	14.0	23.8	8.0	37	57	10 / 200
437512M	E12	15.0	23.8	9.0	37	58	10 / 200
437514M	E14	16.4	23.8	10.0	37	59	10 / 200
437516M	E16	18.8	23.8	11.0	37	63	10 / 200
437518M	E18	20.5	23.8	12.5	39	68	10 / 200
437520M	E20	22.8	23.8	14.0	39	72	10 / 200
437522M	E22	24.6	23.8	16.0	39	78	10 / 200
437524M	E24	26.5	23.8	16.0	39	85	10 / 160

4275M

1/2"

- Long type
- Chrome vanadium steel
- Polished, chrome plated
- DIN 3120

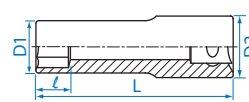

KT NO.	mm	D1 mm	D2 mm	ℓ mm	L mm	⚖️	📦
427508M	E08	11.4	23.8	7.0	77	106	6 / 120
427510M	E10	13.2	23.8	7.5	77	112	6 / 120
427512M	E12	15.0	23.8	9.0	77	121	6 / 120
427514M	E14	16.4	23.8	10.0	77	127	6 / 120
427516M	E16	18.8	23.8	11.0	77	143	6 / 120
427518M	E18	20.5	23.8	12.5	77	148	6 / 120
427520M	E20	22.8	23.8	14.0	77	161	6 / 120
427522M	E22	24.6	23.8	16.0	77	178	6 / 96
427524M	E24	26.5	23.8	16.0	77	197	6 / 96

433E

1/2"

- For torx plus external screw
- DIN 3120

KT NO.	mm	D1 mm	D2 mm	ℓ mm	L mm	⚖️	📦
433E18M	E18	21	25.8	15.0	45	91	6 / 96
433E20M	E20	23	25.8	15.0	45	98	6 / 96
433E22M	E22	-	25.8	17.0	45	110	6 / 96
433E24M	E24	27.8	26.0	18.0	45	119	6 / 96
433E26M	E26	29.8	26.0	19.0	45	125	6 / 96
433E28M	E28	31.8	26.0	21.0	45	125	6 / 96
433E30M	E30	33.8	26.0	22.0	45	131	6 / 96
433E32M	E32	35.8	26.0	23.0	45	149	6 / 96

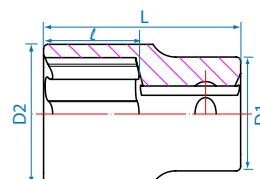

Spark Plug Socket

KT No. & D1



4630RC



4660



4635RC



4665C



4670



4675



- 6 / 12 points
- Size combined
 - 16.0mm (5/8")
 - 20.8mm (13/16")
- Inside sleeve
 - rubber
 - magnet
- DIN 3120
- 14mm use for Toyota Yaris, Vios



Magnet

463014RC - Thin walled design

463514RC - Thin walled design

463016RC - Thin walled design

466016 - Thin walled design

463516RC - Thin walled design

466516C - Thin walled design

KT NO.	Type	Size inch mm	D mm	L mm			
463014RC	12 points Rubber	- 14.0	19.05	70	70	12 / 240	
463016RC	12 points Rubber	5/8 16.0	20.75	70	72	10 / 200	
466016	12 points Magnet	5/8 16.0	20.75	70	74	10 / 200	
463514RC	6 points Rubber	- 14.0	19.05	70	70	12 / 240	
463516RC	6 points Rubber	5/8 16.0	20.75	70	76	10 / 200	
466516C	6 points Magnet	5/8 16.0	20.75	70	77	10 / 200	
463021RC	12 points Rubber	13/16 20.8	27.7	70	142	12 / 120	
466021	12 points Magnet	13/16 20.8	27.7	70	139	12 / 120	
463521RC	6 points Rubber	13/16 20.8	27.7	70	148	12 / 120	
466521C	6 points Magnet	13/16 20.8	27.7	70	150	12 / 120	
467014C	12 points Metal clip	- 14.0	19.05	70	70	12 / 240	
467016	12 points Metal clip	5/8 16.0	20.75	70	73	10 / 200	
467021	12 points Metal clip	13/16 20.8	27.7	70	121	12 / 120	
467514C	6 points Metal clip	- 14.0	19.05	70	70	12 / 240	
467516	6 points Metal clip	5/8 16.0	20.75	70	74	10 / 200	
467521	6 points Metal clip	13/16 20.8	27.7	70	162	12 / 120	



463021RC



466021



463521RC



466521C

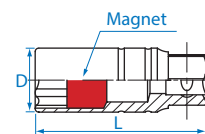
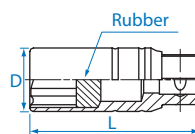

467514C



467014C

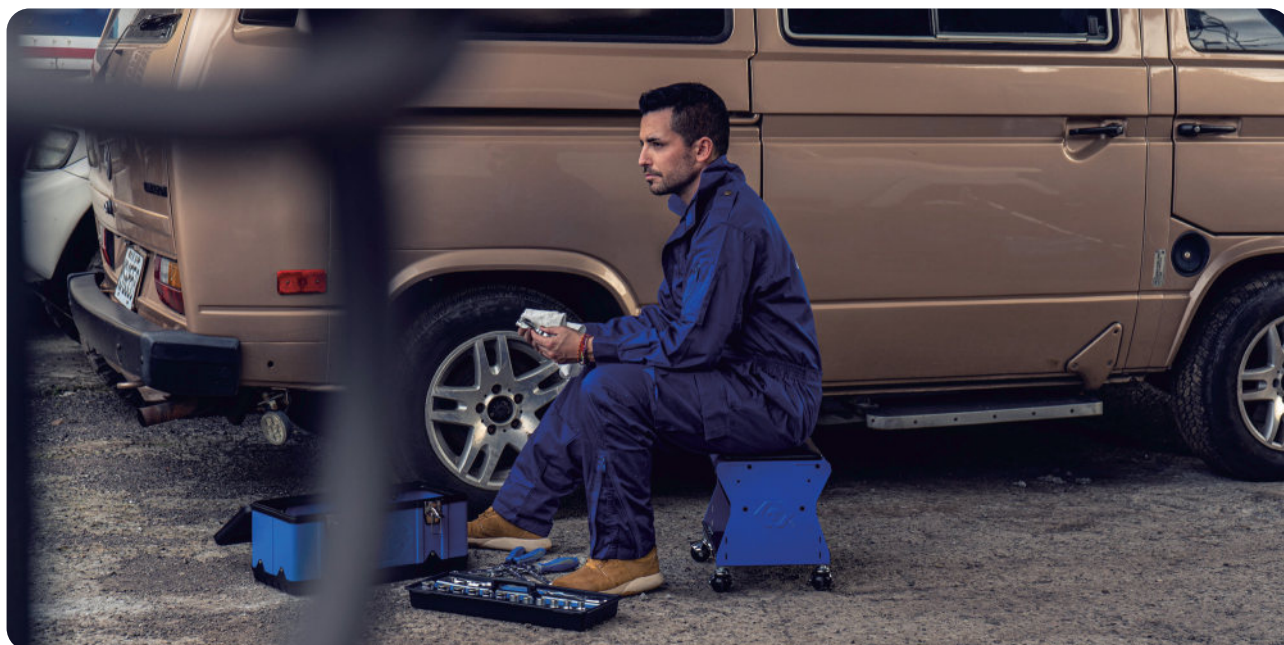
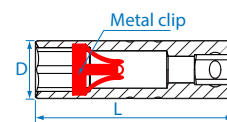

Bit Socket



In order to get normal life of bit socket, always use within limited torque to bit.



4021

⊕ 1/2"

- Phillips head
- DIN ISO 8764-1



KT NO.	⊕ No.	Overall length mm		
402102	PH2	60	67	10 / 180
402103	PH3	60	77	10 / 180
402104	PH4	60	68	10 / 180

4025

4035

40D5

⊙ 1/2"

- Hexagon head
- DIN 7422

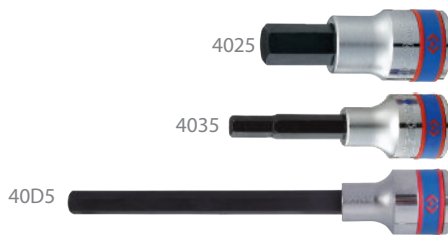

KT NO.	mm / Inch	Overall length mm		
402503	H3	60	65	10 / 180
402504	H4	60	65	10 / 180
402505	H5	60	66	10 / 180
402506	H6	60	68	10 / 180
402507	H7	60	67	10 / 180
402508	H8	60	70	10 / 180
402509	H9	60	78	10 / 180
402510	H10	60	80	10 / 180
402511	H11	60	95	10 / 180
402512	H12	60	94	10 / 180
402514	H14	60	114	10 / 180
402517	H17	66	166	10 / 100
402519	H19	66	225	10 / 120
403504	H4	80	74	6 / 120
403505	H5	80	75	6 / 120
403506	H6	80	77	6 / 120
403507	H7	80	77	6 / 120
403508	H8	80	80	6 / 120
403509	H9	80	91	6 / 120
403510	H10	80	93	6 / 120
403511	H11	80	111	6 / 120
403512	H12	80	113	6 / 120
403514	H14	80	140	6 / 120
403517	H17	80	193	6 / 120
403519	H19	80	259	6 / 96
40D506	H6	140	101	6 / 120
40D508	H8	140	102	6 / 120
40D510	H10	140	131	6 / 120
402506S	3/16	60	66	10 / 180
402507S	7/32	60	68	10 / 180
402508S	1/4	60	69	10 / 180
402509S	9/32	60	71	10 / 180
402510S	5/16	60	76	10 / 180
402512S	3/8	60	79	10 / 180
402514S	7/16	60	92	10 / 180
402516S	1/2	60	110	10 / 180
402518S	9/16	66	156	10 / 120
402520S	5/8	66	162	10 / 120
402524S	3/4	66	226	10 / 120

4022

⊖ 1/2"

- Slotted head
- DIN ISO 5264 / 3120



KT NO.	Tip width mm	Tip thickness mm	Overall length mm		
402208	8	1.2	60	68	10 / 180
402210	10	1.6	60	75	10 / 180
402212	12	2.0	60	89	10 / 180
402214	14	2.5	60	104	10 / 180
402216	16	2.5	60	104	10 / 180

40D0

⬡ 1/2"

- Hexagon with ball point head



KT NO.	mm	Overall length mm		
40D006	H6	140	101	6 / 120
40D008	H8	140	103	6 / 120
40D010	H10	140	132	6 / 120

4026

4036

⊙ 1/2"

4046

4066

- Spline head
- DIN 3120

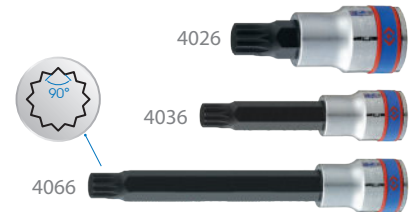

KT NO.	Size	Overall length mm		
402605	M5	60	69	10 / 180
402606	M6	60	67	10 / 180
402608	M8	60	70	10 / 180
402610	M10	60	78	10 / 180
402612	M12	60	91	10 / 180
402614	M14	60	108	10 / 180
402616	M16	60	144	10 / 120
402618	M18	60	195	10 / 120
403605	M5	80	75	6 / 120
403606	M6	80	76	6 / 120
403608	M8	80	76	6 / 120
403610	M10	80	91	6 / 120
403612	M12	80	110	6 / 120
403614	M14	80	135	6 / 120
404605	M5	100	83	6 / 120
404607	M7	100	84	6 / 120
404608	M8	100	85	6 / 120
404610	M10	100	105	6 / 120
404612	M12	100	128	6 / 120
404614	M14	100	161	6 / 120
406608	M8	140	102	6 / 120
406609	M9	140	131	6 / 120
406610	M10	140	130	6 / 120
406612	M12	140	168	6 / 120
406614	M14	140	212	6 / 120
406616	M16	140	301	6 / 72

Bit Socket

KT No. & D1



HAND SOCKET & ACCESSORIES

404108



- Spline head
- DIN 3120
- Use for Toyota Tercel cylinder head bolt



KT NO.	Size	Overall length mm	Weight	Quantity
404108	M8.9	100	123	6 / 120

402A



- Pentagon head
- For using on most vehicles fitting brake system



KT NO.	Size	Overall length mm	Weight	Quantity
402A10	10	60	89	10 / 180

402B



- Spline head
- Tamper resistant type
- For gearbox and sump plugs of Audi A4/A6/A3, Golf IV/LT of VW



KT NO.	Size	Overall length mm	Weight	Quantity
402B16	M16	66	151	10 / 120
402B18	M18	66	204	10 / 120

4049



- Use for VW, Audi, Fiat cylinder head bolt



KT NO.	Size	Overall length mm	Weight	Quantity
404904	M4	100	81	6 / 120
404905	M5	100	83	6 / 120
404906	M6	100	83	6 / 120
404907	M7	100	83	6 / 120
404908	M8	100	84	6 / 120
404909	M9	100	102	6 / 120
404910	M10	100	103	6 / 120
404925	M10.5	100	102	6 / 120
404912	M12	100	127	6 / 120
404913	M13	100	156	6 / 120
404914	M14	100	159	6 / 120
404916	M16	100	215	6 / 120

4027

- For tamper resistant torx screw
- DIN 3120



4027



4037

KT NO.	Size	Overall length mm	Weight	Quantity
402720	T20H	60	65	10 / 180
402725	T25H	60	66	10 / 180
402727	T27H	60	66	10 / 180
402730	T30H	60	66	10 / 180
402740	T40H	60	67	10 / 180
402745	T45H	60	70	10 / 180
402750	T50H	60	68	10 / 180
402755	T55H	60	77	10 / 180
402760	T60H	60	105	10 / 180
403720	T20H	80	74	6 / 120
403725	T25H	80	73	6 / 120
403727	T27H	80	74	6 / 120
403730	T30H	80	77	6 / 120
403740	T40H	80	76	6 / 120
403745	T45H	80	77	6 / 120
403750	T50H	80	79	6 / 120
403755	T55H	80	90	6 / 120
403760	T60H	80	131	6 / 120

4023

- For torx internal screw
- DIN 3120



4023



4033

KT NO.	Size	Overall length mm	Weight	Quantity
402320	T20	60	68	10 / 180
402325	T25	60	66	10 / 180
402327	T27	60	68	10 / 180
402330	T30	60	65	10 / 180
402340	T40	60	67	10 / 180
402345	T45	60	69	10 / 180
402350	T50	60	69	10 / 180
402355	T55	60	78	10 / 180
402360	T60	60	106	10 / 180
402370	T70	60	110	10 / 180
403320	T20	80	76	6 / 120
403325	T25	80	74	6 / 120
403327	T27	80	75	6 / 120
403330	T30	80	75	6 / 120
403340	T40	80	78	6 / 120
403345	T45	80	76	6 / 120
403350	T50	80	79	6 / 120
403355	T55	80	92	6 / 120
403360	T60	80	132	6 / 120
403370	T70	80	136	6 / 120



Ratchet & Set

KT No. & D1

4725

FINE GEAR 1/2"

- Reversible ratchet
- 8° gear action degree (45 teeth)
- DIN 3122

KT NO.	Overall length			
	inch	mm		
4725-10FR	10	250	590	1 / 40
4725-10GR	10	250	631	1 / 20
4725-12FR	12	300	652	2 / 40
4725-12GR	12	300	693	1 / 20
4725-12BR	12	300	637	2 / 40
4725DKR01	renewal kits		-	-

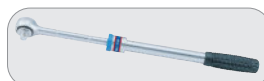

4725DKR01



4725-10FR
4725-12FR



4725-10GR
4725-12GR

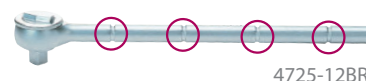

4725-12BR

4755

FINE GEAR 1/2"

- Reversible ratchet
- 5° gear action degree (72 teeth)
- DIN 3122

KT NO.	Overall length			
	inch	mm		
4755-10G	10	262	540	1 / 20
4755DK	renewal kits		-	-



4755DK

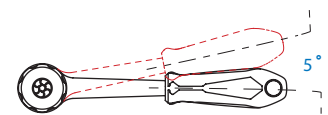

4756

QUICK RELEASE **FINE GEAR** 1/2"

- Quick release reversible ratchet
- 5° gear action degree (72 teeth)
- DIN 3122

KT NO.	Overall length			
	inch	mm		
4756-10G	10	262	539	1 / 20
4756DK	renewal kits		-	-



4756DK

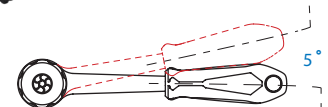

Ratchet



4752

QUICK RELEASE FINE GEAR 1/2"

- Quick release swivel reversible ratchet
- 5° gear action degree (72 teeth)
- Multi-angle design for difficult-to-reach fasteners

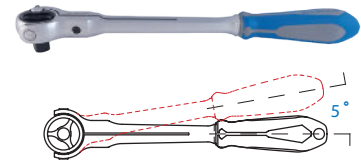

KT NO.	Overall length			
	inch	mm		
4752-12G	12	312	639	1 / 20
4752DK	renewal kits		-	-



4752DK

4760

MINI RATCHET FINE GEAR 1/2"

- Mini reversible ratchet
- 5° gear action degree (72 teeth)
- Two teeth pawl action
- DIN 3122

KT NO.	Overall length			
	inch	mm		
4760-05	4-3/4	120	209	5 / 90
4760-05G	5-1/2	137	201	4 / 72
4760DK01	renewal kits		-	-



4760DK01



4760-05



4760-05G

4762

QUICK RELEASE 1/2"

- Quick release reversible ratchet
- 11° gear action degree (32 teeth)
- Two teeth pawl action
- DIN 3122

KT NO.	Overall length			
	inch	mm		
4762-10G	10	250	536	5 / 30
4762-10F	10	250	580	6 / 36
4762-10P	10	250	552	6 / 36
4762-15G	15	375	693	5 / 20
4762DK	renewal kits		-	-



4762DK



4762-10G / 4762-15G



4762-10F



4762-10P

4768

1/2"

- Reversible ratchet
- 11° gear action degree (32 teeth)
- Two teeth pawl action
- DIN 3122

KT NO.	Overall length			
	inch	mm		
4768-10G	10	250	542	5 / 30
4768-10F	10	250	589	6 / 36
4768-10P	10	250	557	6 / 36
4768-15G	15	375	723	5 / 20
4768-15F	15	375	760	6 / 24
4768DK	renewal kits		-	-



4768DK



4768-10G / 4768-15G



4768-10F / 4768-15F



4768-10P

4771

QUICK RELEASE 1/2"

- Quick release reversible ratchet
- 11° gear action degree (32 teeth)
- Two teeth pawl action
- DIN 3122

KT NO.	Overall length			
	inch	mm		
4771-10BR	10	250	551	2 / 40
4771-10FR	10	250	620	2 / 40
4771-10GR	10	262	540	1 / 20
4771DK	renewal kits		-	-

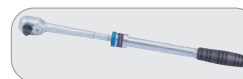

4771DK



4771-10BR



4771-10FR



4771-10GR

Ratchet

KT No. & D1

4774

1/2"

- Universal joint reversible ratchet
- 11° gear action degree (32 teeth)
- Two teeth pawl action
- DIN 3122
- 15° rotation

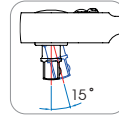

4774-10F



4774-10G



4774DK

KT NO.	Overall length		g	/
	inch	mm		
4774-10F	10	250	619	2 / 40
4774-10G	10	262	553	1 / 20
4774DK	renewal kits		-	-

4779

1/2"

- Reversible ratchet
- 11° gear action degree (32 teeth)
- Two teeth pawl action
- DIN 3122



4779-10BR



4779-10FR



4779-10GR



4779DK01

KT NO.	Overall length		g	/
	inch	mm		
4779-10BR	10	250	559	2 / 40
4779-10FR	10	250	626	2 / 40
4779-10GR	10	262	551	1 / 20
4779DK01	renewal kits		-	-

4772

1/2"

- Design spec. similar to DIN 3122, ISO 3315
- Made from special-purpose drop-forged and hardened **aluminium**
- Finishing - anodic treatment - black driver by phosphate sunk
- The mechanism as in all 4771/9 ratchets is made from high-quality steel



4772DK01

KT NO.	Overall length		g	/
	inch	mm		
4772-10F	10	250	350	1 / 25
4772DK01	renewal kits		-	-

4781

QUICK RELEASE 1/2"

- Quick release flexible and reversible ratchet
- 11° gear action degree (32 teeth)
- Two teeth pawl action
- DIN 3122

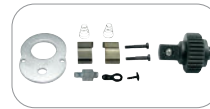

4781DK

KT NO.	Overall length		g	/
	inch	mm		
4781-12F	12	300	783	1 / 20
4781DK	renewal kits		-	-

Ratchet Set

7773GS

QUICK RELEASE 1/2" & 1/4"

- 1/4" & 1/2" DR. 90 teeth dustproof ratchets
- 90 teeth ratchet mechanism, allowing ratchet action in very tight spaces
- IP51, dustproof design



2773-55GS



4773-10GS

Contents		kg	/
	2773-55GS	0.70	1 / 36
	4773-10GS	0.70	1 / 36

90 Teeth Dustproof Ratchet **PAT.**



HAND SOCKET & ACCESSORIES



- Material
 - chrome vanadium alloy steel handle
 - chrome molybdenum steel (gear) driver
- Finishing
 - polished, chrome plated
 - black driver by phosphate sunk



4773-10GS

- Quick release reversible ratchet
- 4° gear action degree (90 teeth)
- DIN 3122
- IP51

KT NO.	Square DR.	Overall length		g	📦/📦
		inch	mm		
4773-10GS	1/2"	10	262	500	1 / 25
4773DK				renewal kits	



4773DK

4773-22GS

1/2" DR. Telescopic Ratchet Wrench

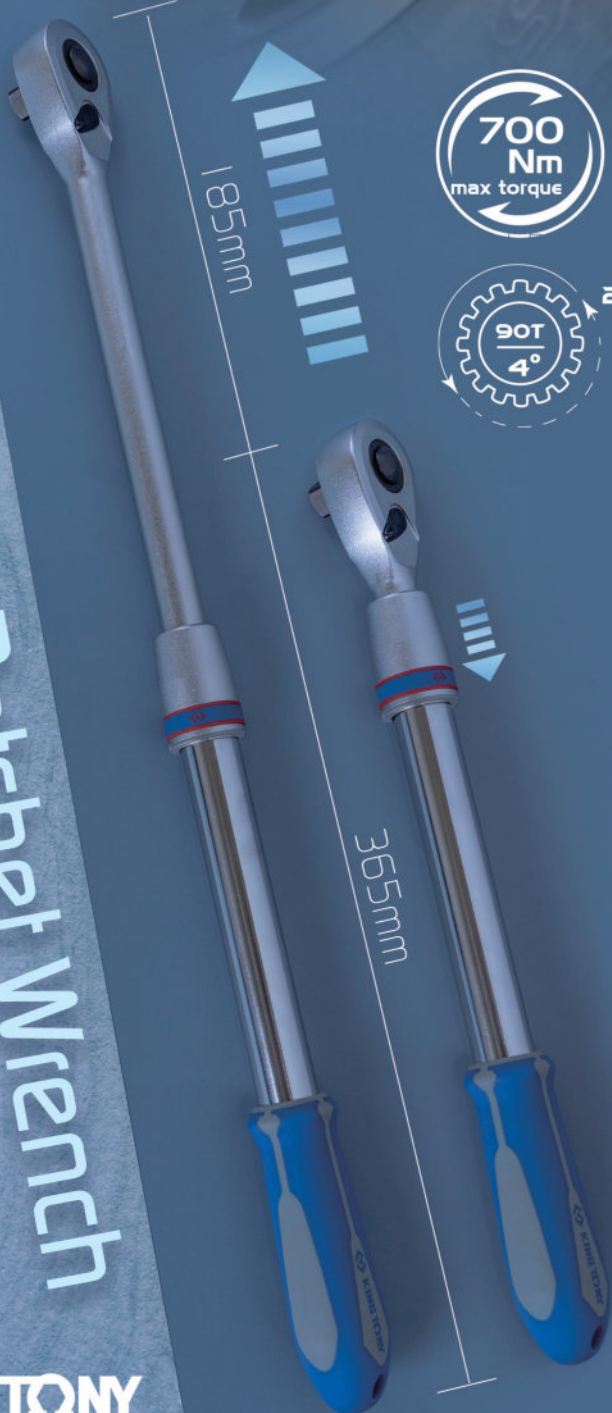

700 Nm
max torque

90T
4°
20%

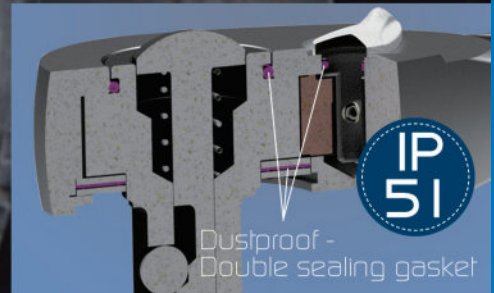

KT NO.	Max L mm	Min L mm		
4773-22GS	550	365	1200	1 / 20
477DK	renewal kits			

- Special telescopic design saves storage space
- Pull down to unlock, fix, and quickly adjust
- Dust-proof design to increase product life
- 700N·m torque value, which far exceeds the standard
- Higher torque, less effort. Extra long lever for increased power: max 550 mm
- The long plastic handle has a hook at its end for hanging and working at height
- 4° gear action degree (90 teeth)



HAND SOCKET & ACCESSORIES

Accessory



The offset extension bar has less strength than normal extension bar. Do not use as a normal extension bar.



4121 1/2"

- Adjustable handle
- Push-Lock design



KT NO.	Overall length		Scales	Box/Kit
	inch	mm		
4121-11GR	11-1/2	295	535	1 / 20

4251 1/2"

- Extension bar
- DIN 3123



KT NO.	Overall length		Scales	Box/Kit
	inch	mm		
4251-02R	2	55	105	12 / 216
4251-03R	3	75	143	6 / 120
4251-04R	4	100	182	4 / 80
4251-05R	5	125	197	4 / 80
4251-06R	6	150	231	4 / 64
4251-08R	8	200	294	4 / 80
4251-10R	10	250	364	4 / 64

4104PR 1/2"

- Extension bar

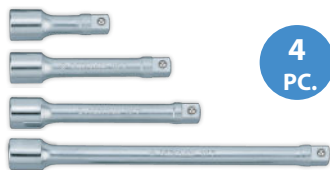

4 PC.

Contents 0.84 1 / 25

KT NO.	3"	5"	6"	10"
4251				

4221 1/2"

- Extension bar
- DIN 3123



KT NO.	Overall length		Scales	Box/Kit
	inch	mm		
4221-18	18	450	548	1 / 20
4221-24	24	600	685	1 / 20
4221-30	30	750	860	1 / 20
4221-36	36	900	1055	1 / 20

4223 1/2"

- Offset extension bar, wobble extension bar
- Max. torque : 320 N·m
- DIN 3123



KT NO.	Overall length		Scales	Box/Kit
	inch	mm		
4223-02R	2	55	98	12 / 216
4223-05R	5	125	194	4 / 80
4223-10R	10	250	358	4 / 64

4293 1/2"

- Multi-function of extension bar and offset extension bar, wobble extension bar
- Max. torque : 320 N·m
- DIN 3123



KT NO.	Overall length		Scales	Box/Kit
	inch	mm		
4293-02	2	55	97	12 / 216
4293-05	5	125	191	4 / 80
4293-10	10	250	356	4 / 64

4311 1/2"

- Speed brace
- DIN 3122

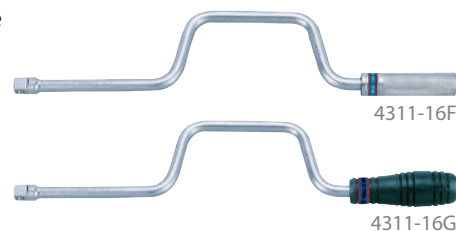

KT NO.	Overall length		Scales	Box/Kit
	inch	mm		
4311-16F	16-1/4	412	610	5 / 40
4311-16G	16-1/4	412	499	5 / 40

4452 1/2"

- Flexible handle
- Action degree -180°
- DIN 3122



KT NO.	Overall length		Scales	Box/Kit
	inch	mm		
4452-15FR	15	375	718	2 / 24
4452-18FR	18	450	810	2 / 20
4452DK	renewal kits(for 15F/18F)		62	-

KT NO.	Overall length		Scales	Box/Kit
	inch	mm		
4452-24FR	24	600	1138	20
4452DK1	renewal kits(for 24F)		62	-

4453 1/2"

- Flexible handle
- Action degree -180°
- New pattern design added in firm and powerful elements
- New forge technologies I-Beam shank offer 15% lightweight
- DIN 3122



4452DK



KT NO.	Overall length		Scales	Box/Kit
	inch	mm		
4453-15F	15	375	630	2 / 24
4453-18F	18	450	708	2 / 20
4452DK	renewal kits(for 15F/18F)		62	-



4461 1/2"

- Extends from 18 in. to 24 in.
- This breaker bar has a 180° swivel head and an ergonomically designed handle
- Break free stubborn or stuck fasteners
- Flexible head for multiple angles of use

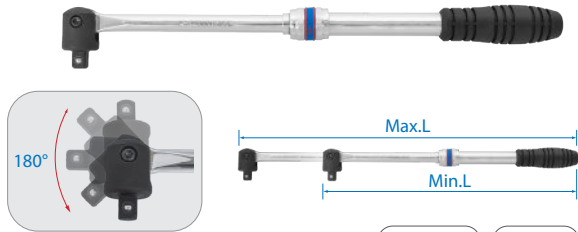

KT NO.	Max.L mm	Min.L mm		
4461-24G	600	450	1185	1 / 10
4462DK	renewal kits			

4462 1/2"

- Flexible handle
- Action degree -180°
- DIN 3122



KT NO.	Overall length inch	Overall length mm		
4462-18F	18	463	1046	1 / 20
4462-24F	24	613	1350	1 / 20
4462DK	renewal kits			

4572 1/2"

- Sliding T-handle
- DIN 3122



KT NO.	Overall length inch	Overall length mm		
4572-10	10	250	371	2 / 40
4572-12	12	300	426	2 / 40
4572DK	renewal kits			

4573 1/2"

- Sliding T-handle
- DIN 3120



KT NO.	Overall length inch	Overall length mm		
4573-10R	10	250	470	2 / 40
4573DK	renewal kits			

4581 1/2"

- 90° L-handle
- DIN 3122



KT NO.	Overall length inch	Overall length mm		
4581-10	10	250	450	1 / 40

4583 1/2"

- 105° L-handle
- DIN 3120



KT NO.	Overall length inch	Overall length mm		
4583-12R	12-1/2	315	550	1 / 40

4584 1/2"

- 90° L-handle
- DIN 3120

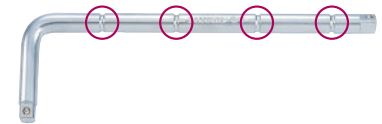

KT NO.	Overall length inch	Overall length mm		
4584-12R	12	300	547	40

4148 1/2"

- Bit holder



KT NO.	Size	Overall length mm		
414808S	1/4"	38	50	10 / 200
414810S	5/16"	38	55	10 / 200
414810M	10 mm	38	56	10 / 200

4813 4816 1/2"

- Adapter
- Convert to 3/8" drive or 3/4" drive
- 4813 → Max. torque : 202 N-m
- DIN 3123, ISO 3316



KT NO.	Spec.		
4813	1/2"Fx3/8"M	56	10 / 200
4816	1/2"Fx3/4"M	111	10 / 200

Accessory

KT No. & D1



HAND SOCKET & ACCESSORIES

4791R

1/2"

- Universal joint
- DIN 3120, ISO 3316

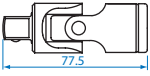

KT NO.	Overall length inch	mm		
4791R	3	77.5	159	5 / 100

4794

1/2"

- Universal joint
- 30° rotation
- Short pattern design enables greater access in confined spaces

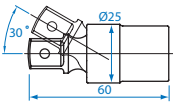

KT NO.	Overall length inch	mm		
4794	2-3/8	60	105	5 / 180

9113PR

1/4" 3/8" 1/2"

- Universal joint
- Ball point type universal joint & with hex locking design
- Short pattern design enables greater access in confined spaces



3 PC.

Contents	0.20	6 / 108
2793	31mm	
3793	43mm	
4793	59mm	

4844R

1/2"

- 1/2" drive (1/2" F x 1/2" M)
- Finish : Chrome Alloy Steel, chrome plated
- Reversible
- 5° gear action degree (72 teeth)
- Apply to 1/2" accessory (Ex : 4453-15F)
- Apply to 1/2" torque wrench (Ex : 3446E series)



PAT.

Outer diameter 37 x Height 62 mm

KT NO.	Overall length inch	mm		
4844R	2-7/16	62	250	1 / 64

KT NO.	Contents		
4122FR	4844R 4453-15F	880	1 / 20
4122FR01	4844R 4453-18F	958	1 / 20

Magnetic Insert

91000M

- Magnetic insert for sockets
- Powerful retention force
- Reusable
- 11 PC. set, for metric sockets

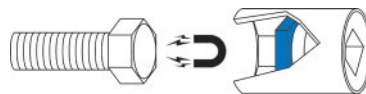

KT NO.	Size (mm)		
91000M	8, 10, 11, 12, 13, 14, 15, 16, 17, 18, 19 mm	42	12 / 144

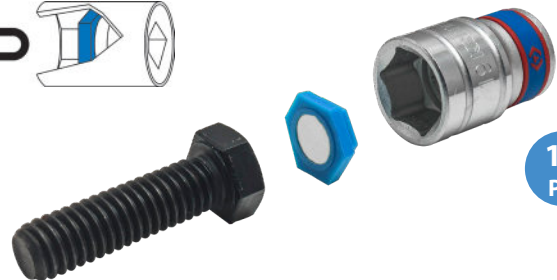

11 PC.

Socket Rail Set

4010MR

4010SR

4510MR

4510SR 1/2"

- Socket rail 230mmL



8 PC.

4010MR/4510MR



4010SR/4510SR

KT NO. Contents 0.64 4 / 32

4010MR	4330MR	10, 12, 13, 14, 17, 19, 21, 22	8740908
4510MR	4335MR		
4010SR	4330SR	3/8, 7/16, 1/2, 9/16, 11/16, 3/4, 13/16, 7/8	
4510SR	4335SR		

4208MR10

4308MR10 1/2"

- Socket rail 240mmL



8 PC.

KT NO. Contents 1.22 2 / 12

4208MR10	4230MR	12, 13, 14, 17, 19, 21, 22, 23	8741108
4308MR10	4235MR		

4106PR

1/2"

- Socket rail 230mmL



6 PC.

Contents 0.51 4 / 32

4375M	E10, E12, E14, E16, E18, E20
8740906	

4148PR10

1/2"

- Socket rail 240mmL



8 PC.

Contents 1.24 2 / 12

4275M	E10, E12, E14, E16, E18, E20, E22, E24
8741108	

4118MR

1/2"

- Socket rail 230mmL



8 PC.

Contents 0.57 4 / 32

4014M	RB8, RB9.5, RB10, RB10.5, RB12, RB12.7, RB13.5, RB19
8740908	

4311MR

1/2"

- Socket rail 230mmL



11 PC.

Contents 0.92 2 / 12

4335MR	10, 11, 13, 14, 15, 17, 18, 19
4725-10GR	4572-10
4251-05R	8740908

Bit Socket Rail Set

4110PR10

1/2"

- Socket rail 240mmL
- For hex head screw
- H : 60mm



9 PC.

Contents 0.77 2 / 12

4025	H3, H4, H5, H6, H7, H8, H10, H12, H14
8741009	

4110SR10

1/2"

- Socket rail 240mmL
- For hex head screw
- H : 60mm



9 PC.

Contents 1.22 2 / 12

4025S	3/16, 7/32, 1/4, 9/32, 5/16, 3/8, 1/2, 9/16, 5/8
8741009	

Bit Socket Rail Set

4120PR10

1/2"

- Socket rail 240mmL
- For hex head screw
- H : 80mm

9 PC.



Contents 1.0 2 / 12



4108PR10

1/2"

- Socket rail 240mmL
- For hex head screw
- H : 60mm

8 PC.



Contents 0.96 2 / 12

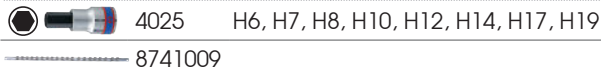

4126PR

1/2"

- Socket rail 127mmL
- For spline head screw
- H : 60mm

4 PC.



Contents 0.38 4 / 32



4105PR

1/2"

- Socket rail 150mmL
- For spline head screw
- H : 60 & 66 mm

5 PC.



Contents 0.57 4 / 32

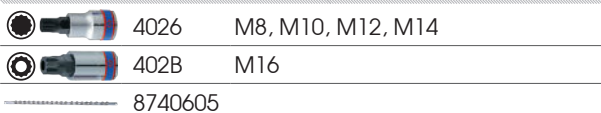

4136PR

1/2"

- Socket rail 127mmL
- For spline head screw
- H : 80mm

4 PC.



Contents 0.46 4 / 32

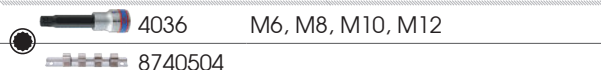

4109PR10

1/2"

- Socket rail 240mmL
- For torx head screw
- H : 60mm

9 PC.



Contents 0.74 2 / 12

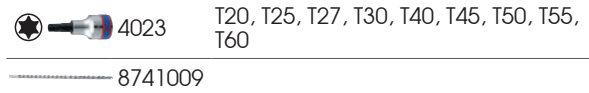

4119PR10

1/2"

- Socket rail 240mmL
- For torx head screw
- H : 80mm

9 PC.



Contents 0.84 2 / 2

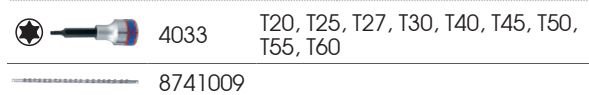

4116PR

1/2"

- Socket rail 180mmL
- For ribe head screw
- H : 100mm

6 PC.



Contents 0.38 4 / 24

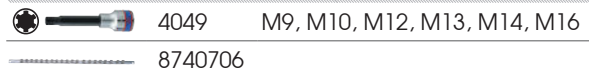

Socket Rail

874

1/2"

- Rail length from 160 mm to 560 mm

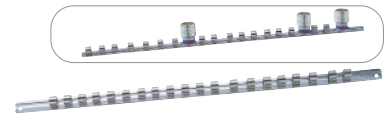

KT NO. L (mm)

870406 160

870410 260

870422 560

8740 -

8740809D1

1/2"

- Socket rail carrier with retaining clip
- 446mm roller cabinet



KT NO. Square drive Clip L (mm)

8740809D1 1/2" 9 508

Socket & Wrench Set

4313MR01 1/2"



13 PC.

Contents 1.55 1 / 12

- 4335MR 8, 10, 11, 12, 13, 14, 15, 16, 17, 18, 19
- 4771-10GR 4251-06R

4213MR 1/2"



11 PC.

Contents 1.39 1 / 15

- 4330MR 10, 11, 12, 13, 14, 17, 19, 21, 22
- 4766-10G 4251-06R



Socket Set

4208MR 4208SR
4308MR 1/2"

Metal case size (mm) :
246 x 103 x 38 (0.034 cuft)



4208MR / 4308MR



4208SR

8 PC.

KT NO. Contents 1.75 1 / 12

KT NO.	Contents	
4208MR	4230M	12, 13, 14, 17, 19, 21, 22, 23
4308MR	4235M	
4208SR	4230S	1/2, 9/16, 5/8, 11/16, 3/4, 13/16, 7/8, 15/16

4215MR 4315MR 1/2"

Metal case size (mm) :
445 x 135 x 50 (0.107 cuft)



15 PC.

KT NO. Contents 3.80 1 / 6

KT NO.	Contents	
4215MR	4230M	10, 11, 12, 13, 14, 15, 16, 17, 19, 21, 22, 24, 27, 30, 32
4315MR	4235M	

4216MR 4316MR 1/2"

Metal case size (mm) :
445 x 135 x 50 (0.107 cuft)



16 PC.

KT NO. Contents 3.68 1 / 6

KT NO.	Contents	
4216MR	4230M	10, 11, 12, 13, 14, 15, 16, 17, 18, 19, 21, 22, 24, 27, 30, 32
4316MR	4235M	



Bit Socket Set

4109PR

Metal case size (mm) :
198 x 105 x 32 (0.023 cuft)

9
PC.



4109PR



4119PR

KT NO.	Contents	kg	1/2"
4109PR	4023 T20, T25, T27, T30, T40, T45, T50, T55, T60	1.04	1 / 20
4119PR	4033	1.13	1 / 20

4110PR

Metal case size (mm) :
198 x 105 x 32 (0.023 cuft)

9
PC.



4110PR



4120PR

KT NO.	Contents	kg	1/2"
4110PR	4025 H3, H4, H5, H6, H7, H8, H10, H12, H14	1.03	1 / 20
4120PR	4035 H4, H5, H6, H7, H8, H10, H12, H14, H17	1.38	1 / 20

4117PR

Metal case size (mm) :
224 x 94 x 40 (0.03 cuft)

7
PC.



Contents

kg 1.22 1 / 8

- 4026 M6, M8, M10, M12, M14
- 402B M16, M18

4128PR

Metal case size (mm) :
224 x 94 x 40 (0.03 cuft)

8
PC.



Contents

kg 1.24 1 / 8

- 4026 M5, M6, M8, M10
- 402B M16
- 4036 M8, M10, M12

Socket Set

4501MR

Metal case size (mm) :
392 x 90 x 50 (0.062 cuft)

15
PC.



Contents

kg 3.28 1 / 6

- 4335MR 8, 10, 11, 12, 13, 14, 17, 19, 21, 22, 24, 27
- 4779-10FR
- 4251-05R
- 4452-15FR

4511MR

Metal case size (mm) :
445 x 187 x 50 (0.147 cuft)

24
PC.



4511MR



4511SR

KT NO. Contents kg 5.5 1 / 4

4511MR	4335MR	10, 11, 12, 13, 14, 15, 16, 17, 18, 19, 20, 21, 22, 23, 24, 27, 30, 32	463521RC
			4725-12GR
4511SR	4335SR	3/8, 7/16, 15/32, 1/2, 9/16, 19/32, 5/8, 11/16, 3/4, 25/32, 13/16, 7/8, 15/16, 1, 1-1/16, 1-1/8, 1-3/16, 1-1/4	4572-10
			4251-05R
			4251-10R
			4223-02R

Socket Set

4012MR

Metal case size (mm) :
445 x 135 x 50 (0.106 cuft)



4012MR / 4512MR

4012SR

4512MR

4512SR

1/2"

14
PC.

KT NO.	Contents		Kg 3.50	1 / 6
4012MR	4330MR	10, 11, 12, 13, 14, 17, 19, 21, 22, 24	463021RC	4768-10F
4512MR	4335MR		463521RC	4572-12
4012SR	4330SR	3/8, 7/16, 15/32, 1/2, 9/16, 11/16, 3/4, 13/16, 7/8, 15/16	463021RC	4251-05R
4512SR	4335SR		463521RC	

4016SR

Metal case size (mm) :
370 x 150 x 54 (0.105 cuft)



4516MR

4516MR

4516SR

1/2"

16
PC.

KT NO.	Contents		Kg 3.68	1 / 6
4016SR	4330SR	3/8, 7/16, 1/2, 9/16, 5/8, 11/16, 3/4, 13/16, 7/8, 15/16, 1-1/16	463021RC	4791R 4779-10FR
4516MR	4335MR	10, 11, 12, 13, 14, 17, 19, 21, 23, 24, 27	463521RC	4251-05R
4516SR	4335SR	3/8, 7/16, 15/32, 1/2, 9/16, 5/8, 3/4, 13/16, 15/16, 1, 1-1/16	463521RC	4452-15FR

4220MR

Metal case size (mm) :
445 x 135 x 50 (0.106 cuft)

KT NO. Contents Kg 3.83 1 / 6

4220MR	4330MR	8, 9, 10, 11, 12, 13, 14, 15, 16, 17, 18, 19, 21, 22, 24, 27	4755-10G
4320MR	4335MR		4251-05R 4791R 4251-10R



20
PC.

4223MR

Metal case size (mm) :
490 x 205 x 52 (0.185 cuft)

Contents Kg 4.7 1 / 3

4330MR	10, 11, 12, 13, 14, 15, 16, 17, 18, 19, 21, 22, 23, 24, 27, 30, 32, 34
4771-10G	4461-24G
4791R	4251-05R

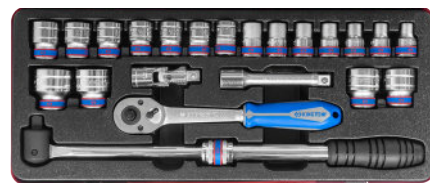

22
PC.

Socket Set

4031MR

4031SR

4531MR

4531SR

1/2"

Metal case size (mm) :
445 x 187 x 50 (0.147 cuft)



4031MR / 4531MR











4031SR / 4531SR

23
PC.

KT NO.

Contents

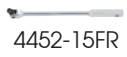
5.3 1/4

KT NO.	Contents	5.3 1/4
4031MR	 4330MR 10, 11, 12, 13, 14, 15, 16, 17, 18, 19, 20, 21, 22, 23, 24, 27, 30, 32	 4779-10GR  4251-05R  4251-10R
4531MR	 4335MR	
4031SR	 4330SR 5/16, 3/8, 7/16, 15/32, 1/2, 9/16, 19/32, 5/8, 11/16, 3/4, 25/32, 13/16, 7/8, 15/16, 1, 1-1/16, 1-3/16, 1-1/4	 4452-15FR  4791R
4531SR	 4335SR	

4024MR

4024SR

4524MR

4524SR

4033MR

4033SR

4533MR

4533SR

1/2"

Metal case size (mm) :
445 x 187 x 50 (0.147 cuft)



4024SR / 4524SR



4024MR / 4524MR

24
PC.



4033SR / 4533SR





















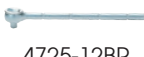

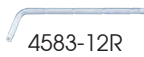

4033MR / 4533MR

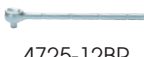
KT NO.

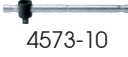
Contents

5.7 1/4

KT NO.	Contents	5.7 1/4
4033SR	 4330SR 5/16, 3/8, 7/16, 15/32, 1/2, 9/16, 19/32, 5/8, 11/16, 3/4, 25/32, 13/16, 7/8, 15/16, 1, 1-1/16, 1-3/16, 1-1/4	 463021RC  463521RC  4779-10BR
4533SR	 4335SR	 4121-11GR  4223-02R
4033MR	 4330MR 10, 11, 12, 13, 14, 15, 16, 17, 18, 19, 20, 21, 22, 23, 24, 27, 30, 32	 463021RC  463521RC  4725-12BR
4533MR	 4335MR	 4583-12R
4024SR	 4330SR 3/8, 7/16, 15/32, 1/2, 9/16, 19/32, 5/8, 11/16, 3/4, 25/32, 13/16, 7/8, 15/16, 1, 1-1/16, 1-1/8, 1-3/16, 1-1/4	 463021RC  463521RC  4725-12BR
4524SR	 4335SR	 4573-10
4024MR	 4330MR 10, 11, 12, 13, 14, 15, 16, 17, 18, 19, 20, 21, 22, 23, 24, 27, 30, 32	 463021RC  463521RC
4524MR	 4335MR	

Socket Set

4224MR

4324MR

1/2"

Metal case size (mm) :
445 x 187 x 50 (0.147 cuft)



24
PC.

4224MR / 4324MR

KT NO.

Contents

5.3 1 / 4

4224MR	4330MR	10, 11, 12, 13, 14, 15, 16, 17, 18, 19, 20, 21, 22, 23, 24, 27, 30, 32	4779-10GR	4452-18FR	4572-12	4251-05R 4251-10R	4791R
4324MR	4335MR						

4028MR

4028SR

4528MR

4528SR

1/2"

Metal case size (mm) :
445 x 187 x 50 (0.147 cuft)



4028MR / 4528MR



4028SR / 4528SR

24
PC.

KT NO.

Contents

5.3 1 / 4

4028MR	4330MR	10, 11, 12, 13, 14, 15, 16, 17, 18, 19, 20, 21, 22, 23, 24, 27, 30, 32	463021RC	4779-10GR	4791R
4528MR	4335MR		463521RC		4251-05R 4251-10R
4028SR	4330SR	3/8, 7/16, 15/32, 1/2, 9/16, 19/32, 5/8, 11/16, 3/4, 25/32, 13/16, 7/8, 15/16, 1, 1-1/16, 1-1/8, 1-3/16, 1-1/4	463021RC	4779-10GR	4572-10
4528SR	4335SR		463521RC		

4032MR

4032SR

4532MR

4532SR

1/2"

Metal case size (mm) :
445 x 187 x 50 (0.147 cuft)



4032MR / 4532MR



4032SR / 4532SR

24
PC.

KT NO.

Contents

5.3 1 / 4

4032MR	4330MR	10, 11, 12, 13, 14, 15, 16, 17, 18, 19, 20, 21, 22, 23, 24, 27, 30, 32	463021RC	4779-10FR	4251-05R 4251-10R
4532MR	4335MR		463521RC		
4032SR	4330SR	5/16, 3/8, 7/16, 15/32, 1/2, 9/16, 19/32, 5/8, 11/16, 3/4, 25/32, 13/16, 7/8, 15/16, 1, 1-1/16, 1-3/16, 1-1/4	463021RC	4452-15FR	4791R
4532SR	4335SR		463521RC		

Socket Set







4325MR

1/2"

Metal case size (mm) :
445 x 187 x 50 (0.147 cuft)

Contents

5.3 1 / 4

		4335MR	10, 11, 12, 13, 14, 15, 16, 17, 18, 19, 20, 21, 22, 23, 24, 27, 30, 32
		4779-10GR	4251-05R 4251-10R
		4311-16G	4572-10



24 PC.

4026MR

4026SR

4526MR

4526SR

4026MR03

4026SR03

4526MR03

4526SR03

4026MR04

1/2"

Metal case size (mm) :
445 x 187 x 50 (0.147 cuft)



4026MR / 4526MR



4026SR / 4526SR



4026SR03 / 4526SR03



4026MR03 / 4526MR03

























4026MR04

24 PC.

KT NO.

Contents

5.95 1 / 4

KT NO.	Socket	Contents	Socket	Contents
4026MR	 4330MR	10, 11, 12, 13, 14, 15, 16, 17, 18, 19, 20, 21, 22, 23, 24, 27, 30, 32	 463021RC	 4768-10F
4526MR	 4335MR		 463521RC	
4026MR03	 4330MR	8, 10, 11, 13, 14, 15, 16, 17, 18, 19, 20, 21, 22, 23, 24, 27, 30, 32	 4791R	 4779-10GR
4526MR03	 4335MR			 4452-15FR
4026MR04	 4330MR			 4572-12
				 4755-10G
4026SR	 4330SR	5/16, 3/8, 7/16, 15/32, 1/2, 9/16, 19/32, 5/8, 11/16, 3/4, 25/32, 13/16, 7/8, 15/16, 1, 1-1/16, 1-3/16, 1-1/4	 463021RC	 4768-10F
4526SR	 4335SR		 463521RC	
4026SR03	 4330SR		 4791R	 4779-10GR
4526SR03	 4330MR			

Socket Set

4033MR03

Metal case size (mm) :
445 x 187 x 50 (0.147 cuft)









4533MR03

1/2"



24
PC.

4033MR03 / 4533MR03

KT NO.			Contents	4.43	1 / 4	
4033MR03		4330MR	10, 11, 12, 13, 14, 15, 16, 17, 18, 19, 20, 21, 22, 23, 24, 27, 30, 32	 4791R	 4779-10BR	 4223-02R
4533MR03		4335MR		 4121-11GR	 4573-10	 4583-12R

4030CR

Metal case size (mm) :
445 x 187 x 50 (0.147 cuft)

4030CR01

1/2"











4030CR



4030CR01

30
PC.

KT NO.			Contents	4.90	4.92	1 / 4
4030CR		4330MR	10, 12, 13, 14, 15, 16, 17, 18, 19, 21, 22, 23, 24, 30, 32	 4768-10P	 4452-15FR	 4791R
4030CR01		4330SR	7/16, 1/2, 9/16, 5/8, 11/16, 3/4, 13/16, 7/8, 15/16, 1	 4779-10GR	 4251-05R	 4813

4034MR

4034MR06

4534MR

4534MR06

1/2"

Metal case size (mm) :
476 x 282 x 57 (0.27 cuft)

















4034MR / 4534MR



4034MR06 / 4534MR06

33
PC.

KT NO.			Contents	7.6	7.9	1 / 2
4034MR		4330MR	8, 9, 10, 11, 12, 13, 14, 15, 16, 17, 18, 19, 20, 21, 22, 23, 24, 25, 26, 27, 28, 29, 30, 32	 463021RC	 463516RC	4251-03R 4251-05R 4251-10R
4534MR		4335MR		 463521RC	 4779-10FR	 4572-12
4034MR06		4330MR		 463014RC	 4779-10GR	 4452-18FR
4534MR06		4335MR		 463016RC		 4791R

Socket Set

4535MR

1/2"

Metal case size (mm):
445 x 187 x 50 (0.147 Cuft)

Contents

4.46 1 / 4

4335MR	10, 11, 12, 13, 14, 15, 17, 19, 21, 22, 24, 27, 30, 32
1836H	H5, H6, H7, H8, H10, H12
1836T	T25, T27, T30, T40, T45, T50
1836P	PH2, PH3
463516RC	463514RC
4251-05R 4251-10R	4771-10GR 4794 414810S



35 PC.

4042CR

4042CR02

4542CR

4542CR02

1/2"

Metal case size (mm):
476 x 282 x 57 (0.27 cuft)



4042CR / 4542CR



4042CR02 / 4542CR02

42 PC.

KT NO.

Contents

8.5 1 / 2

4042CR	4330MR 4330SR	10, 11, 12, 13, 14, 15, 16, 17, 18, 19, 20, 21, 22, 23, 24, 27, 30, 32, 5/16, 3/8, 7/16, 1/2, 9/16, 19/32, 5/8, 11/16, 3/4, 25/32, 13/16, 7/8, 15/16, 1, 1-1/16, 1-1/8, 1-3/16, 1-1/4	463021RC	4768-10F	4452-18FR
4542CR	4335MR 4335SR		463521RC		4251-05R 4251-10R
4042CR02	4330MR 4330SR		4779-10GR		
4542CR02	4335MR 4335SR		4791R		4572-12

4044CR

4544CR

1/2"

Metal case size (mm):
476 x 282 x 57 (0.27 cuft)

KT NO. Contents

8.5 1 / 2

4044CR	4330MR	8, 9, 10, 11, 12, 13, 14, 15, 16, 17, 18, 19, 20, 21, 22, 23, 24, 25, 26, 27, 28, 30, 32	4779-10BR
	4330SR	3/8, 7/16, 1/2, 9/16, 5/8, 11/16, 3/4, 13/16, 7/8, 15/16, 1, 1-1/8, 1-3/16, 1-1/4	4573-10
	4335MR	8, 9, 10, 11, 12, 13, 14, 15, 16, 17, 18, 19, 20, 21, 22, 23, 24, 25, 26, 27, 28, 30, 32	4121-11GR
4544CR	4335SR	3/8, 7/16, 1/2, 9/16, 5/8, 11/16, 3/4, 13/16, 7/8, 15/16, 1, 1-1/8, 1-3/16, 1-1/4	4583-12R 4791R 4223-02R



43 PC.