

Protocol converter Modbus RS-485 via mobile communication EM - 486



OPERATING MANUAL

Quality control system on the production complies with requirements ISO 9001:2008

Dear customer,
Company NOVATEK-ELECTRO LTD. thanks you for purchasing our products.
You will be able to use properly the product after carefully studying the Operating Manual.

CONTENT

1 PURPOSE	5
1.1 Purpose device	3
1.2 Overall and setting dimensions	5
1.3 Operating Conditions	5
2 COMPLETE SUPPLY SET OF EM-486	6
3 TECHNICAL SPECIFICATION	6
4 DESIGN	7
5 THE INTENDED USE	7
5.1 Preparation for operation	8
5.2 Use of the EM-486	10
5.3 Settings	12
6 MAINTENANCE	30
7 SERVICE LIFE AND WARRANTY	30
8 TRANSPORTATION AND STORAGE	30
Appendix A. Versions and modifications	31
Appendix B. Connection	32
Appendix C. Operation logic programming	35
Appendix D. Updating of firmware	43

ATTENTION! ALL REQUIREMENTS OF THIS OPERATING MANUAL ARE COMPULSORY TO BE MET!



WARNING! – PRODUCT TERMINALS AND INTERNAL COMPONENTS ARE UNDER POTENTIALLY LETHAL VOLTAGE
TO ENSURE THE PRODUCT SAFE OPERATION IT IS STRICTLY FORBIDDEN THE

FOLLOWING:

- **TO CARRY OUT MOUNTING WORKS AND MAINTENANCE WITHOUT DISCONNECTING THE PRODUCT FROM THE MAINS;**
- TO OPEN AND REPAIR THE PRODUCT INDEPENDENTLY;
- TO OPERATE THE PRODUCT WITH MECHANICAL DAMAGES OF THE CASE.

IT IS NOT ALLOWED WATER PENETRATION ON TERMINALS AND INTERNAL ELEMENTS OF THE PRODUCT.

During operation and maintenance the regulatory document requirements must be met, namely:

- Regulations for Operation of Consumer Electrical Installations;
- Safety Rules for Operation of Consumer Electrical Installations;
- Occupational Safety when in Operation of Electrical Installations;

Installation, adjustment and maintenance of the product must be performed by qualified personnel having studied this Operating Manual.

In compliance with the requirements of this Operating Manual and regulations the product is safe for use.

This Operating Manual is intended to familiarize you with the unit, the requirements for safety, operation and maintenance procedures of the Protocol converter RS-485 via mobile communication EM-486 (hereinafter referred to as EM-486).

The product meets the requirements:

UBZ complies with the requirements of the following international standards:

- Low-voltage Switchgear and Control-gear; Part 1: General Rules (IEC 60947-1:2004);
- Low-voltage switchgear and control gear – Part 6-2: Multiple function equipment - Control and protective switching devices (or equipment)(IEC 60947-6-2:1992)
- Industrial, scientific and medical (ISM) radio-frequency equipment - Electromagnetic disturbance characteristics – Limits and methods of measurement (CISPR 11:2004)
- Electromagnetic compatibility (EMC). Part 4-2: Testing and measurement techniques –Electrostatic discharge immunity test (IEC 61000-4-2:2001)

Harmful substances in amounts exceeding maximum permissible concentrations are not available.

TERMS AND ABBREVIATIONS

10Base-T – Ethernet standard for twisted pair communication with the speed of 10Mbit/s;

100Base-T – Ethernet standard for twisted pair communication with the speed of 100Mbit/s;

8P8C/RJ45 – is an unified socket for 10Base-T / 100Base-T network connections;

Twisted pair – is a pair of insulated conductors inside the cable, which are twisted together in order to reduce the distortion of the transmitted signal;

Indicator – is a LED element;

Display – OLED graphical indicator

Client – is a device, which is addressing the other devices (server) with a request to perform certain functions;

Package – is a block of data to be transmitted between devices;

Server – is a unit, which performs specific functions at the request of other units;

ASCII – is a table of standard codes for information interchange;

DHCP – It is the Protocol that allows network nodes automatically obtaining the parameters of TCP/IP (IP address);

Ethernet – is a standard for packet network communication and transmitting data between units (e.g., PCs);

FTP – the FTP protocol of a file transfer according to the standard TCP/IP

GPRS – GPRS – technology of a packet transmission of data on mobile communication

GSM - the standard of digital mobile communication

HTTP – is a protocol for transferring Web-pages and other data over "client-server" technology;

Internet – is a global routing system of units for storing and transferring data;

IP (protocol) – is a routable protocol for transferring data over Ethernet. It is a part of TCP/IP and used for Internet;

IP (address) – is a node address, which is unique within a single network, operating over the IP protocol;

IPv4 – is a four byte IP-address;

MAC (address) – is an address, used for device authentication during Ethernet transmissions. It is usually unique although qualified personnel can change it under certain circumstances.

MAC-48 – is a six byte MAC-address;

Modbus – is a standard and protocol for packet communication over the "client-server" technology for industrial electronic units;

Modbus RTU – is a communication protocol of the unit for bite wise transfer of the package;

Modbus ASCII – is a communication protocol of the unit for the transfer of package in the form of ASCII-symbols;

Modbus TCP – is a protocol for transferring Modbus packages under the TCP/IP standard;

NTP – It is the Protocol for clock synchronization at the network nodes with variable delays of transmission;

RS-485/EIA-485 – is a network standard for communicating units over the twisted pair;

SMS – a standard and technology of transmitting the brief messages via mobile communication;

TCP/IP – is a standard and a set of protocols for transferring data along the networks with delivery verification;

WEB – is a system for accessing documents on the server, used in the Internet.

WEB-page – is a document, file, recourse, which is available on the Web-server;

WEB-browser – is a WEB-server client for accessing the WEB-pages, which is primarily using the HTTP protocol.

1 PURPOSE

1.1 PURPOSE DEVICE

EM-486 provides for data collection from connected devices (analog transducers and MODBUS devices), data transmission to the server, and access to data (via MODBUS TCP Protocol or via SMS text messages), tracking events and response to the events (control of the relay, recording the values in MODBUS devices).

Protocol converter RS-485 via mobile communication EM-486 provides access to readings of gauges and registers of Modbus connected via RS-485 interface **MODBUS TCP** with the help of text SMS messages, EM-486 has:

- Flexible options of connection (via wire or wireless communication, automatic method selection of communicating with a server, automatic or manual selection of GSM provider and communication parameters, resetting of MAC-address and other Ethernet settings);
- Protection of access (password for setting mode, filter of IP-address for setting or connection to Modbus network, connection only to the selected server with automatic login, password for control via SMS);
- Different modes of data interchange via RS-485 (RTU or ASCII, with checking of parity for even-odds or without checking, wide range of transmitting rate, adjustable delay);
- programming the collection of data, events, and action for events (see Appendix B);
- Programmable outputs for reaction at events and alarms;
- Programmable inputs for analog sensors;
- Programmable impulse meters for every sensor;
- Power output for sensors;
- Reserve power supply input;
- Service functions (real time clock, firmware updating option).

1.2 OVERALL AND SETTING DIMENSIONS

1.2.1 The unit drawing, together with the overall and setting dimensions, is provided in Figure 1.1.

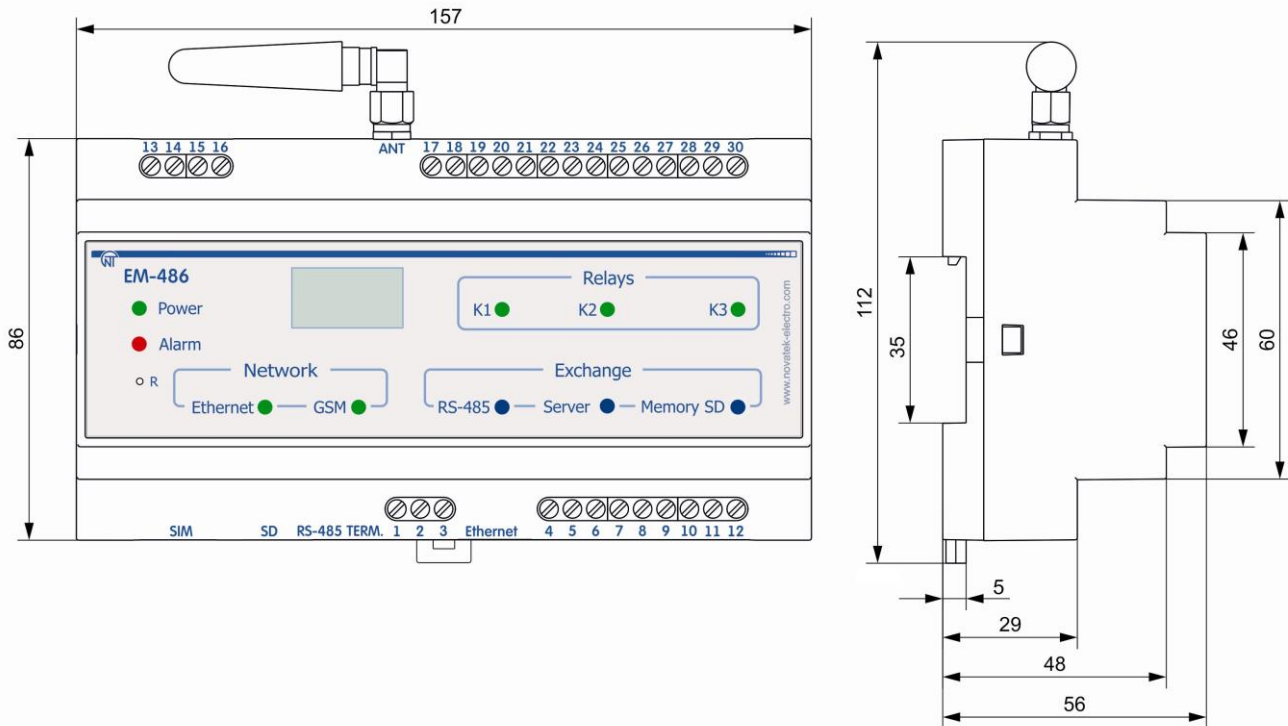

Figure 1.1 – Overall dimensions of the unit

The front panel of ET-486 is provided in Figure 1.2.

1.3 OPERATING CONDITIONS

EM-486 is designed for operation in the following conditions:

- Ambient temperature: from minus 35 to +55°C;
- Atmospheric pressure: from 84 to 106.7 kPa;
- Relative air humidity (at temperature of +25°C) 30 ... 80%.

ATTENTION! The unit **is not intended** for use:

- in conditions of significant vibration and shocks;
- in high humidity conditions;
- in corrosion environments with content in the air of acids, alkalis, etc., as well as severe contamination (grease, oil, dust, etc.).

If the temperature of the unit after transportation or storage is different from the temperature of the environment in which its operation is assumed, then before connecting to the mains keep the unit in operation conditions for two hours (because on the unit elements condensation may be available).

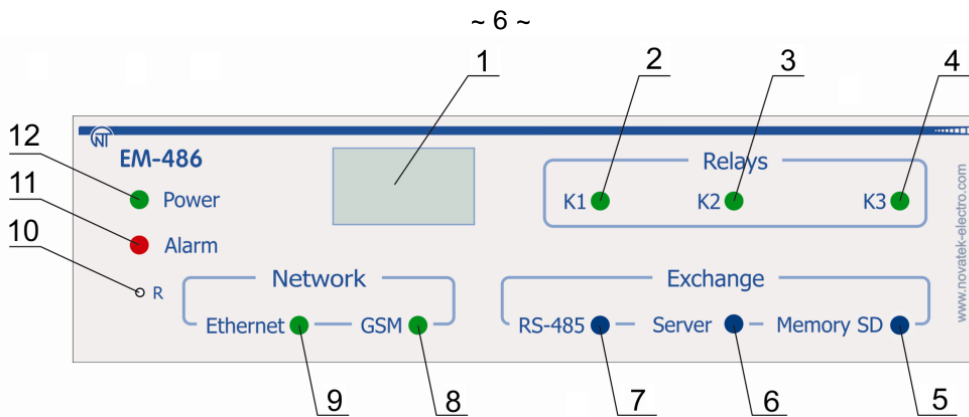

- 1 – Graphic display OLED is designed for indicating the state of the unit, connections, communication interface loading and showing the alarm messages.
- 2 – Indicator «K1» is lit on when relay K1 is activated.
- 3 – Indicator «K2» is lit on when relay K2 is activated.
- 4 – Indicator «K3» is lit on when relay K3 is activated.
- 5 – Indicator «Memory SD» is lit on when there is a memory card in a special slot, is blinking while transmitting the data to the SD-card.
- 6 – Indicator «Server» is lit on when there is a connection with a server for data accumulating, is blinking while data exchange with a server.
- 7 – Indicator «RS-485» is lit on when waiting a respond from a device in Modbus network; is blinking while data exchange via Modbus net work.
- 8 – Indicator «GSM» is blinking every 3 sec. when there is a connection via GSM network, is blinking 3 times per second while data exchange via GPRS.
- 9 – Indicator «Ethernet» is lit on when there is a connection via Ethernet network; it is blinking while data exchange via network.
- 10 – Reset button «R» (is located under the casing and is available for pressing with a help of thin object such as a paper clip) is designed to restart the unit or make factory reset.
- 11 – Alarm indicator «Alarm» warns about an error registration by the analysis of received data.
- 12 - LED Indicator «Power» is lit on when power voltage present.

Figure 1.2 – Front panel of EM-486

2 COMPLETE SUPPLY SET OF EM-486

EM-486 is supplied with table 2.1:

Table 2.1- Complete set of EM-486

Item	Quantity
EM-486	1 pc.
Cable for Ethernet connection	1 pc.
GSM antenna (SMA M connector, 50 Ohm)*	1 pc.
Operating manual	1 pc.
MicroSD card (2 Gb)	1 pc.
Shipping box	1 pc.

* other types of antennas are delivered in coordination with the buyer

3 TECHNICAL SPECIFICATIONS

Main technical specifications are resulted in Table 3.1.

Table 3.1 – Main technical specifications of the unit

Operating supply voltage, VAC	230
Supply line frequency, Hz	45 – 65
Data Exchange Interface over the Ethernet network	10Base-T / 100Base-T
Supported Ethernet protocols	UDP, ARP, TCP
Data Exchange Interface over wireless network	GSM
Supported standards of wireless network	SMS, GPRS
Integrated servers	Modbus TCP, HTTP
Maximum number of connections over the Modbus TCP protocol	4
Data Exchange Interface over the Modbus network	RS-485
Supported protocols of Modbus network	Modbus RTU, Modbus ASCII
Maximal output voltage of driver RS-485, V	3.3
Short circuit output voltage of driver RS-485 (maximal), mA	250
Resistance of inbuilt terminator, Ohm	70–1 000 Ohm or deactivated

The recommended number of connected devices in Modbus network - at input voltage of receivers on bus RS-485 not more than 0,125 mA - at input voltage of receivers on bus RS-485 not more than 1 mA	Not more, 256 Not more, 32
Readiness time at power switching on, sec, not more than	15*
Precision measurements of voltage, mV, not more than	40
Precision measurements of current, μ A, not more than	200
Precision measurements of temperature, $^{\circ}$ C, not more than	2
Rated voltage direct current back supply, V	12
Voltage supply, at which operability is maintained: - alternative current, V - direct current, V	90 – 265 127 – 375
Back supply voltage at which operability is maintained, V	9 – 16
Power consumption (under pressure), W, not more than	12
The maximum switched current of output pins, A	16
Universal inputs	4
Types of the connected gauges - gauge with voltage output to 10 V - gauge with current output to 20 mA - 'dry contact' - NTC temperature gauge	
The maximum voltage on the universal input, V	12
The maximum current through the universal input, mA	24
The voltage of sensors power output, V	12
The maximum current of sensors power output, A	0.1
Programmable relay outputs with switching contacts, pcs.	3
Commutation service life of output contacts: - electrical service life under load 16 A($\cos \varphi = 1,0$), times, not less - mechanical service life, times, not less	50 000 10 000 000
Unit purpose	Communication equipment
Nominal operation condition	continuous
The protection level	IP20
Climatic version	NC3.1
Permissible pollution density	II
Overvoltage category	II
Protection class against electrical shock	II
Rated insulation voltage, V	450
Rated impulse withstand voltage, kV	2.5
Cross section of wires of connection terminals, mm ²	0.5-3
Maximal tightening torque of terminals external screws, N*m	0.4
Weight, kg, not more than	0.750
Overall dimensions, H*B*L, mm - with installed antenna - without antenna	157 x 112 x 56 157 x 99 x 56
Standard 35 mm DIN rail mounting	
Operating position	arbitrary
Housing material - self-extinguishing plastic	
Notes: * Connections on the Ethernet networks/Internet can take more time.	

4 DESIGN

EM-486 provides control for MODBUS devices in RS-485 network via Ethernet interfaces or GPRS, or via the SMS. The unit also allows to read data from devices by MODBUS or from connected sensors.

The processor supports connection to the accumulating data cloud server via Ethernet network with a help of micro chip of physical interface of Ethernet (or via GPRS with a help of inbuilt GSM-modem, if connection via Ethernet is not available).

In addition, EM-486 can be connected to Ethernet via MODBUS TCP Protocol to exchange data with MODBUS devices, or with the product. The controller receives and processes SMS with a password and command read/write for Modbus devices.

When inserting a memory card the product reads the internal memory for operational logic – program for data collection and tracking of events. The program runs in the background mode.

Product stores in the internal memory the network settings, parameters of inputs and outputs, the logic of action, the collected data log.

5 THE INTENDED USE

5.1 PREPARATION FOR OPERATION

5.1.1 Preparation for connection:

- Unpack the unit (we recommend to keep the original packing for the entire warranty period of the unit operation);
- Check the unit for damage after transportation; in case of such damages detection, contact the supplier or manufacturer;
- Carefully study the Operating Manual (**pay special attention to the connection diagram to power the unit**);
- If you have any questions regarding the installation of the unit, please contact the manufacturer by telephone number indicated at the end of this Operating Manual.

5.1.2 General instructions

ATTENTION! THE UNIT IS NOT DESIGNED FOR LOAD COMMUTATION IN CASE OF SHORT CIRCUITS. THEREFORE THEY SHOULD BE PROTECTED BY AUTOMATIC CIRCUIT BREAKERS (FUSES) WITH TRIPPING CURRENT NOT EXCEEDING 16 A.

ATTENTION! ALL CONNECTIONS MUST BE PERFORMED WHEN THE UNIT IS DE-ENERGIZED.

Error when performing the installation works may damage the unit and connected devices.

To ensure the reliability of electrical connections you should use flexible (stranded) wires with insulation for voltage of not less than 450 V, the ends of which it is necessary to be striped of insulation for 5±0.5 mm and tightened with bootlaces. Recommended cable cross section for connection is not less 1 mm².

EM-486 connection to RS-485 bus is made by cable of twisted pair type Cat.1 or higher category. It is recommended to use the shielded cable, in this case it should be grounded (in accordance with «ANSI/TIA/EIA-485-A-1998» recommendations).

In case of connection to Ethernet it is necessary to use a cable in a set, or the "twisted pair cable" cable of the Cat.5e category with the 8P8C (RJ-45) tip. Wires fastening should exclude mechanical damage, twisting and insulation abrasion of wires.

IT IS NOT ALLOWED TO LEAVE EXPOSED PORTIONS OF WIRE PROTRUDING BEYOND THE REMOVABLE TERMINAL BLOCK.

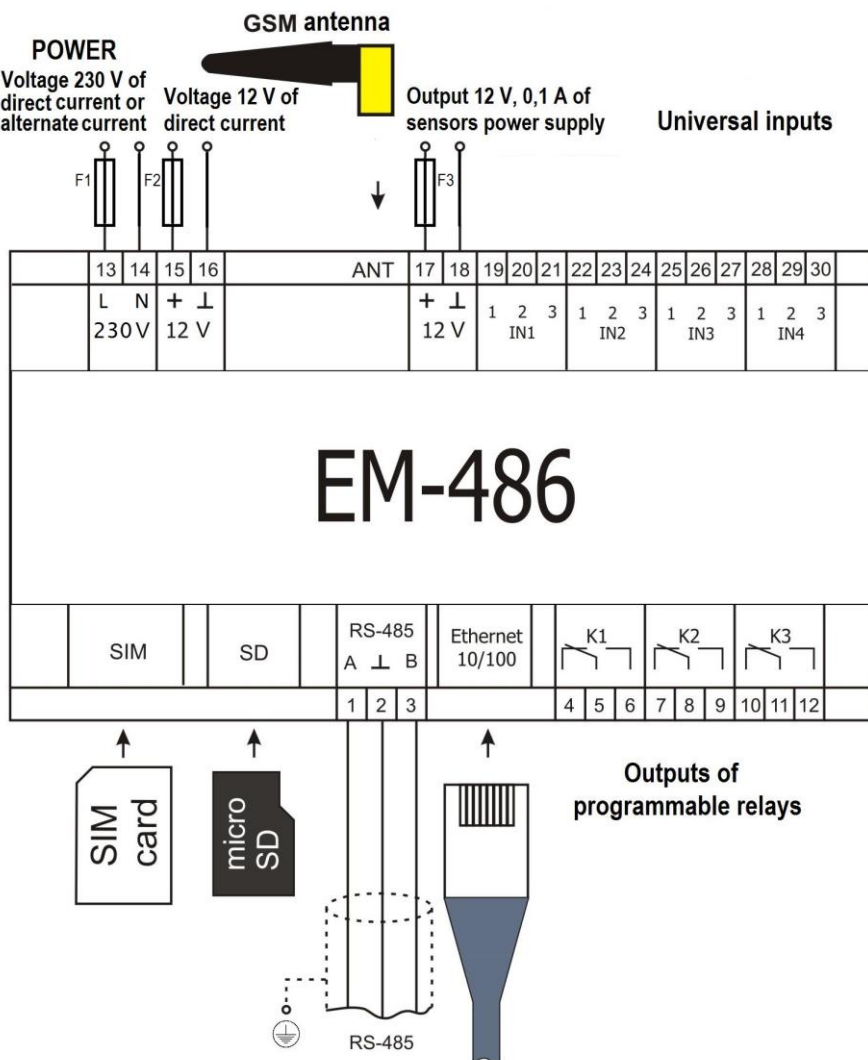

F1 – fuse (fuse element), for current of 0,25 A;
 F2 – fuse (fuse element), for current of 2,5 A;
 F3 – fuse (fuse element), for current of 0,25 A;
 Contact "A" is designed for transferring non-inverted signal,
 Contact "B" is used for the inverted signal.

Figure 5.1 – The Unit connection diagram

For reliable contact it is necessary to perform tightening of screws of removable terminal block with the force specified in Table 3.1.

When reducing the tightening torque, the junction point is heated, terminal block may be melted and wire can burn. If you increase the tightening torque, it is possible to have thread failure of terminal block screws or the compression of the connected wires.

To improve operational properties of the unit it is recommended to install the F1-F3 fuse (fuse element), or the equivalent in power supply circuit for EM-486 (see Fig 5.1).

5.1.3 EM-486 switching on

5.1.3.1 The unit is switched according to the diagram, see Fig 5.1.

5.1.3.2 Switch the cable connection with Modbus network (twisted pair cable of Cat.1 or higher) to the "RS-485" socket and Modbus network (or directly to the unit with RS-485 interface).

If EM-486 is connected to the middle of bus RS-485, or if the bus has external terminals at the ends – set the over switches «RS-485 Term.», located next to slot «RS-485», in position OFF.

If EM-486 is connected at one of the ends of bus RS-485, without a terminal, – set the over switches «RS-485 Term.», located next to the slot «RS-485», in accordance with wave resistance of bus cable, using the Table 5.1.

5.1.3.3 If EM-486 should be connected to Internet via wire line, to local network or directly to PC – connect the Ethernet communication cable to the slot «Ethernet» and to Ethernet network. The details of connection depending on the type of wire line are resulted in Appendix A.

5.1.3.4 In case of sensors connection to Unit universal inputs «IN». The ways of connection of different types are provided in figure 5.2.

5.1.3.5 In case of controlled elements connection to the outputs of programmable relays of the unit «K».

Table 5.1 – Resistance of integrated terminator of bus RS-485

№	Resistance of terminator, Ohm	Position of switches «RS-485 Term.»	№	Resistance of terminator, Ohm	Position of switches «RS-485 Term.»
1	Terminator is deactivated	ON ■ ■ ■ ■ ■ 1 2 3 4 5	13	132	ON ■ ■ ■ ■ ■ 1 2 3 4 5
2	1 000	ON ■ ■ ■ ■ ■ 1 2 3 4 5	14	120*	ON ■ ■ ■ ■ ■ 1 2 3 4 5
3	390	ON ■ ■ ■ ■ ■ 1 2 3 4 5	15	118	ON ■ ■ ■ ■ ■ 1 2 3 4 5
4	300	ON ■ ■ ■ ■ ■ 1 2 3 4 5	16	117	ON ■ ■ ■ ■ ■ 1 2 3 4 5
5	280	ON ■ ■ ■ ■ ■ 1 2 3 4 5	17	107	ON ■ ■ ■ ■ ■ 1 2 3 4 5
6	230	ON ■ ■ ■ ■ ■ 1 2 3 4 5	18	106	ON ■ ■ ■ ■ ■ 1 2 3 4 5
7	200	ON ■ ■ ■ ■ ■ 1 2 3 4 5	19	99	ON ■ ■ ■ ■ ■ 1 2 3 4 5
8	195	ON ■ ■ ■ ■ ■ 1 2 3 4 5	20	92	ON ■ ■ ■ ■ ■ 1 2 3 4 5
9	170	ON ■ ■ ■ ■ ■ 1 2 3 4 5	21	90	ON ■ ■ ■ ■ ■ 1 2 3 4 5
10	167	ON ■ ■ ■ ■ ■ 1 2 3 4 5	22	84	ON ■ ■ ■ ■ ■ 1 2 3 4 5
11	163	ON ■ ■ ■ ■ ■ 1 2 3 4 5	23	74	ON ■ ■ ■ ■ ■ 1 2 3 4 5
12	145	ON ■ ■ ■ ■ ■ 1 2 3 4 5	24	69	ON ■ ■ ■ ■ ■ 1 2 3 4 5

* – is recommended for cable Cat. 3

5.1.3.6 To connect a power supply to the socket "230 V". If necessary, to connect a source of back supply to the power connector "12 V".

5.1.3.7 If EM-486 should be connected to Internet via wireless connection – insert SIM-card of mobile communication operator in SIM slot; connect the antenna to the slot ANT (terminal SMA F).

5.1.3.8. If EM-486 should perform autonomous data collection and tracking of events, put the memory card with the prepared program for logic of actions (see Appendix B) in SD slot.

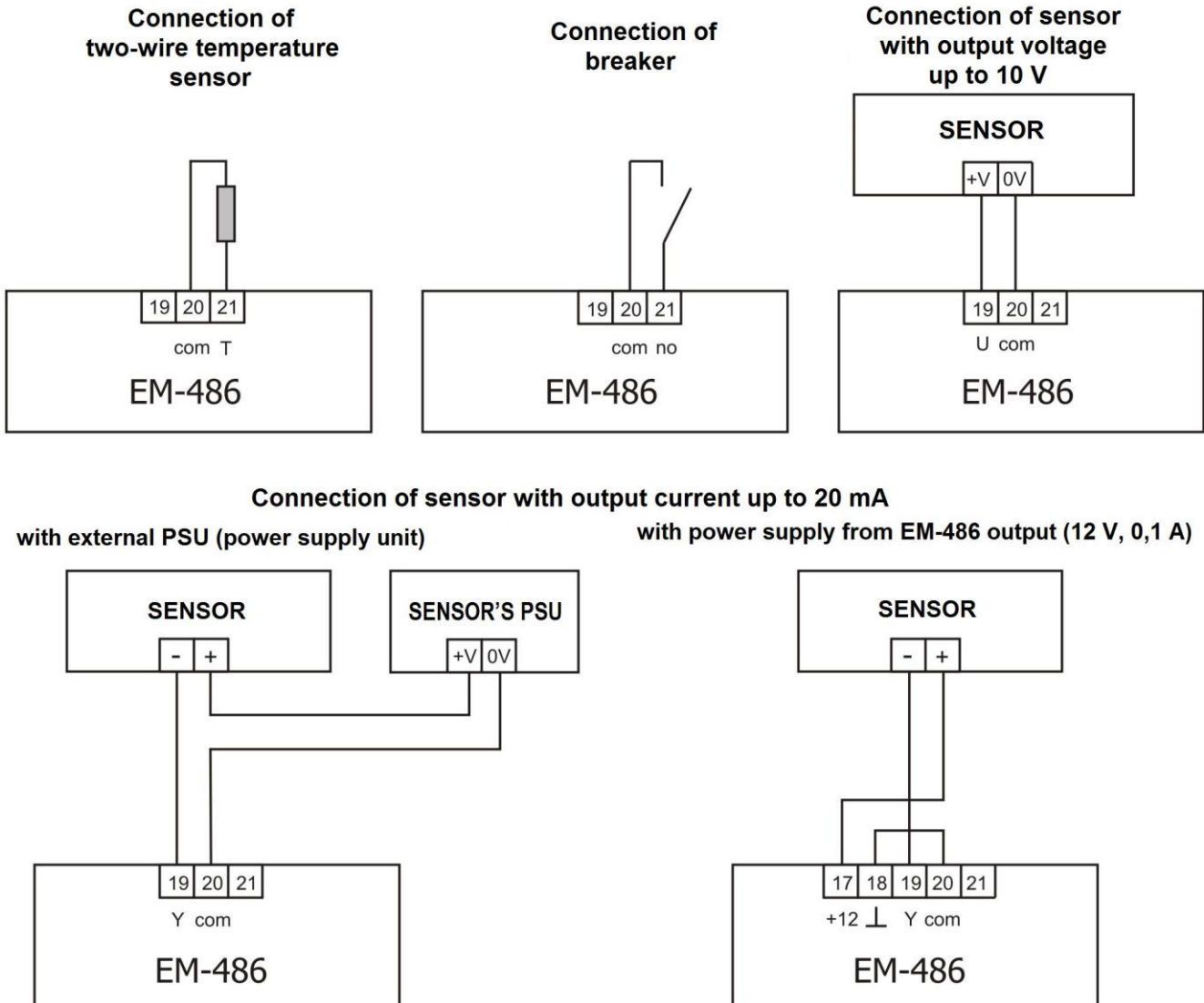

Figure 5.2 – Sensors connection diagram

5.2 USE OF THE EM-486

5.2.1 General information

After power supply is provided to the unit, all indicators light up, except for «Ethernet» and «GSM», and the unit performs the initialization. After this for 2 seconds the indicators, except for indicator of power, light down, and the unit proceeds to start the interface of networks connection. At that the display shows general information about the unit, as resulted in figure 5.3. The start up can take up to 15 seconds, depending on the settings and quality of connection.



Figure 5.3 – Showing the general information about the unit on the display

After wards the unit proceeds with performing the user set program of inquiry for sensors and Modbus devices.

NOTE! CONTINUOUSLY LIT UP OR BLINKING INDICATOR **ALARM** AFTER SWITCHING THE EM-486, INDICATES THE UNIT FAILURE.

The unit provides and supports the connection to Ethernet/GSM networks.

When the indicator **ETHERNET** is lights up means that connection to a network is executed successfully. The blinking indicator **ETHERNET** means data transmitting in the network.

If the indicator **GSM** is blinking one time every three seconds that means the connection to the GSM network is successfully made. If "**GSM**" LED blinks three times per second, it means enabling the data transmission via GPRS.

The display shows the loading of input/output interfaces and a level of GSM signal as shown in figure 5.4.



(«E: 5.2k» - rate of transmitting via Ethernet 5,2 kB/sec, «G: 7-0.3k» - the level of GSM signal is 70%, rate of transmitting via GSM GPRS is 0,3 kB/sec, «S: 15%» - Loading of RS-485 is 15%)

Figure 5.4– Showing the state of connections on the display

5.2.2 Modes of Operation

5.2.2.1 Connection to Server

EM-486 provides and supports connection to the server specified in the unit settings. The light up indicator **Server** means that the connection to server was successfully made. The blinking indicator **Server** means that there is a data exchange with the server. The data interchange with server is mane via one of two protocols: modified Modbus TCP and Modbus TCP.

5.2.2.2 Monitoring of sensors and devices which are connected via RS-485

Controller inquires the registers of Modbus devices, which are connected via RS-485 on requests from the server.

EM-486 measures the reading of connected sensors. The taken readings can be resulted in appropriate scale (according the type of sensor and the settings of the unit). The resulted values are shown on the display in the appropriate view as shown in the figure 5.5.

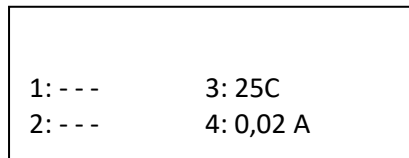

Figure 5.5 – Showing the state of inputs on the display

(sensors 1 and 2 are disconnected, a sensor of temperature 3 – 25°C, a sensor of current 4 – 0,02 A)

In requests of the server can be specified Modbus registers of the EM-486 unit, for saving the readings of sensors, relay states, etc.

5.2.2.3 Access to Modbus network via Modbus TCP interface

EM-486 performs the function of Modbus gateway and waits for network connection via Modbus TCP protocol to port 502. The Modbus TCP connection port can be changed by the user. Connection to PC can be made by any programs – Modbus TCP clients. The client version for Windows software is available for download on the manufacturer’s web-site (<http://novatek-electro.com/en/software.html>).

At inquiry for client connection to Modbus TCP port, the unit checks a list of available connections. If all connections are already engaged, the connection is cancelled otherwise the unit adds it into its internal list of service clients (not more than specified number of clients).

At connection with a client the unit waits for Modbus-inquiry from the client. After receiving the inquiry from the client, the unit analyses the inquiry and, depending on code of inquired function and actual rights of the client, processes and blocks it. At blocking the inquiry EM-486 can generate and send to the client the specified by the user code of MODBUS exception (by default – code 1). The client’s authority level are defied by the entered passwords.

If the inquiry is address to EM-486, the unit does not re-direct it, but processes it and send the reply to the client. The inquiries to the other devices are re-directed in Modbus network, and the reply is waited from the device in MODBUS network – at that event the indicator **RS-485** lights on. If the data is received or if the time is out the indicator **RS-485** lights down.

If there is no reply, EM-486 can generate and send to the client the specified by the user code of Modbus exception (by default – code 11).

If there is a reply received on inquiry, EM-486 sends it to the client who had sent this inquiry.

5.2.2.4 Access to Modbus network via SMS

If there is GSM-connection established, EM-486 receives incoming SMS. All incoming SMS begin with a password. If the password does not match the one specified in settings, SMS is not operated and the reply SMS is not being sent back.

After password through a gap is followed command.

The command consists of an access symbol: (“R” for reading, “W” for writing), an address (identification) of the device in Modbus network, a symbol of resource (“H” for most often used Modbus registers for values saving, thereat the functions of Modbus №3 will be used for reading or №6 for writing or “I” thereat the functions of Modbus №1 will be used for reading) and addresses of resource (register). For the writing function additionally after the space there is the value for locating by address. For example:

- SMS message «abc r1h100» will cause sending the require for reading the register 100 of device 1 (in case when the password for reading via SMS is specified as “abc” in the settings);
- SMS message «stanc12 w2h174 5000» is for writing the value 5000 in register 174 of device 2 (in case when the password for writing via SMS is specified as “stanc12” in the settings).

If the command format is correct, the controller forms the Modbus inquiry.

In the inquiry is addressed to EM-486, the device does not redirect the inquiry but processes it and sends the reply to the client. Inquiries for other devices are redirected in Modbus network and there is waiting for the reply from a device in Modbus net work – thereat the indicator **RS-485** lights up. If the data is received of the time is out, the indicator **RS-485** lights down.

If the correct reply is received on inquiry, EM-486 forms the reply SMS. Every SMS begins with a command prior received from the user. After the command and space there should be the value of register specified in the command (both at reading and writing). The presence of register value in SMS is as confirmation of successful fulfillment of command. For example, SMS «r1h100 2200» means that the value 2200 of register 100 by command for reading from the device 1 has been read.

If as a reply on inquiry there is a Modbus exception code, EM-486 forms SMS with a reply about exception. **SMS begins with a command previously received from the user.** After command and space there should be a warning about exception. The warning consists of a line «EXC.» and a number of exception. After the warning and space there can be the text description of exception with this number (the standard Modbus exceptions are resulted in the table 5.2). For example, the message «r3h873 EXC.2 ILLEGAL DATA ADDRESS» means that for the device 3, a register with address 873 is not executable for reading (or is not available).

When there is no reply via RS-485, EM-486 can generate a specified by user exception code and send it in SMS (by default – code 11).

Table 5.2 – The standard Modbus exception codes

Code	Exception	Description
1	Illegal function	The received code can not be processed
2	Illegal data address	The data address specified in the inquiry is not available
3	Illegal data value	The value in the inquiry is not acceptable
4	Device failure	Non-recoverable failure happened when addressee tried to execute the inquired action
5	Acknowledge	The addressee has received the inquiry and is processing it but this action takes a lot of time.
6	Device busy	The addressee is processing the command. The client can resend the message later.
8	Memory parity error	The parity error was detected when addressee was trying to read the extended memory
10	Gateway paths not available	The gateway can not redirect the inquiry because there is no path (connection) to the addressee
11	Target device failed to response to gateway	The gateway has not received a reply on redirected inquiry because the addressee had not replied on time

5.2.2.5. Data collection and event tracking

When the operational logic program is loaded into the internal memory, the product with the specified interval, reads the specified registers (of connected devices or EM-486), and then performs the specified transformations and the evaluation of the received data. The results can be: sending SMS, turning on/off of the relay, the entry in the specified register (of connected device or EM-486). The program downloading to the internal memory is performed from the memory card. The procedure for preparing and loading the program into the product is described in Appendix C.

5.3 SETTINGS

5.3.1 General information

The connection settings of EM-486 is made via HTTP protocol or via Modbus TCP protocol and serves for specifying the main parameters needed for the unit operation: types of connected sensors, exchange parameters via RS-485, parameters of address in Ethernet network (if Ethernet is used) and server address to which EM-486 is connected automatically.

The adjustable parameters are described in items 5.3.2. The parameters remain saved after the power cut off.

The unit setting can be made by two methods:

- Via WEB-interface, as provided in item 5.3.3;
- Via Modbus-interface as described in item 5.3.4.

NOTE! WHEN CHANGING THE UNIT PARAMETERS THERE CAN BE SPECIFIED THE VALUES HINDERING OR PREVENTING THE CONNECTION OF UNIT IN THE NETWORKS.

Safely remove of the memory card restarting unit or reset of settings to factory values is executed by means of the **R** button available through a hole on a front panel. The button is pressed by a thin subject.

The reset of the unit to factory settings:

- press and hold the reset button **R** for not less than 8 seconds; after 2 seconds of holding the indicator **Alarm** will light on; after 8 seconds of holding the unit will restart, the indicators will blink one time;
- then release the button **R**;

To restart the unit with saving of the user's settings:

- press and hold the reset button **R** during time from 2 to 8 seconds;
- when the indicator **Alarm** lights on, release the button **R**.

To display information about connections or safely remove of the memory card:

- press and release the reset button "**R**", the display shows information about connections, the indicator "Memory SD" will go out. Remove the memory card.

5.3.2 Parameters of EM-486

The sets of parameters available via MODBUS protocol are provided in table 5.3. The internal structure of all sets of parameters is similar to the structure of a set provided in Table 5.8, for exception of the initial address.

The format of parameters presentation in MODBUS registers is described in table 5.4.

Parameters describing the unit are resulted in table 5.5.

The parameters of unit current mode are available for reading and writing and are provided in table 5.6.

The parameters describing the Unit state are available only for reading and are described in table 5.7.

The setting parameters are available only in the setting mode and are listed in table 5.8.

Table 5.3 – The sets of parameters available via Modbus protocol

Set	Description	Access	Address
Changeable settings	The parameters listed in Table 5.8 that can be changed and activated as described in Item 5.3.3 and 5.3.4	Only in mode of setting, Reading or writing	300 – 799
Active settings	The settings being used by the device at the moment	In any mode, Only reading	2300 – 2799
Saved settings	The set is saved regardless the power of the unit and is used at starting of the unit	Only in mode of setting, Only reading	3300 – 3799

Table 5.4 – Format of parameters presentation in Modbus registers

Parameter	Range of values	Description	Number of occupied registers
Number	0–65535	Whole number (16 bit) in standard range of Modbus register values	1
Number	-32768 – +32767	Whole number (16 bit) in additional arithmetic	1
Number	0– 4294967295 in two registers, upper part – the first one	Whole number, which value can exceed the limit for Modbus register (65535)	2
Line of symbols	In each register, a number from 0 to 255 – ASCII-code of symbol or 0 (the end of line)	A set of values every of which is equal to symbol code 1 in ASCII encoding. If the line is shorter than the maximal length then after the last symbol there should be code 0	Max. length of line for the parameter
IP-address (IP-mask)	In every register – one byte (0–255)	Set of four bytes of address IPv4, from left to right	4
MAC-address	In every register – one byte (0–255)	Set of six bytes of address MAC-48, from left to right	6

Table 5.5 – Unit describing parameters

Parameter	Description	Address
Type of unit	The code defining the instrument Modbus at the manufacturer (15 – EM-486)	0
Program version	Program version of firmware of the unit	1
Control code	CRC32 of the unit program firmware	2–3

Table 5.6 – Parameters of unit current mode

Parameter	Range of values	Initial volume	Description	Address
Password enter	Line of symbols	0	At entering the actual password the client receives the appropriate access (see the registers 710-749) At entering the empty line the rights of client are reset to level at the moment of connection	100–119

Parameter	Range of values	Initial volume	Description	Address
Command of control	0–55, Writing in mode of setting	0	0: no activity 1: «Restart» – Restart of the unit 2: «Save» – save the changes of settings via Modbus 3:«Apply» – apply the settings without restart (It is only available for MODBUS, relays, transducers and user parameters); 4: "Save and apply" – similarly to commands 2 and 3; 444: «Back to Factory Settings» – reset the settings to the factory settings 9: "Cancel" – to read the saved settings; 21: «Deactivate relay K1» – switch the relay K1 in normal state until the next command on relay or until reset of the unit 22: «Deactivate relay K2» – switch the relay K2 in normal state until the next command on relay or until reset of the unit 23: «Deactivate relay K3» – switch the relay K3 in normal state until the next command on relay or until reset of the unit 29: «Deactivate all relays» – switch all relays in normal state until the next command on relays or until reset of the unit 31: «Activate relay K1» – switch relay K1 in active state until the next command on relay or until reset of the unit 32: «Activate relay K2» – switch relay K2 in active state until the next command on relay or until reset of the unit 33: «Activate relay K3» – switch relay K3 in active state until the next command on relay or until reset of the unit 39: «Activate all relays» – switch all relays in active state until the next command on relay or until reset of the unit 41: «Control of relay K1» – switch relay K1 to automatic control (normal state before the events which are programmed for switching this relay) until the next command on relay or until reset of the unit 42: «Control of relay K2» – switch relay K2 to automatic control (normal state before the events which are programmed for switching this relay) until the next command on relay or until reset of the unit 43: «Control of relay K3» – switch relay K3 to automatic control (normal state before the events which are programmed for switching this relay) until the next command on relay or until reset of the unit 49: «Control of all relays» – switch all relays to automatic control (normal state before the events which are programmed for switching these relays) until the next command on relay or until reset of the unit 51: "Apply for Modbus" – apply the settings via Modbus and RS-485; 54: "Apply for input" - apply the settings at inputs sensors; 55: "Apply for output" - apply the settings at the output of loading relays. 59: "Apply for user" – apply the settings for the user area of registers; 61: "Reset saved pulse counter at input 1" – before sending this command, you should open the access to change the saved counters (see command 13785); 62: "Reset saved pulse counter at input 2" – (see command 13785); 63: "Reset saved pulse counter at input 3" – (see command 13785); 64: "Reset saved pulse counter at input 1" – (see command 13785); 13785: "Start changing the stored pulse counters" – it should be sent every time before usage of commands 61–64; 35381: "Start setting the clock" – it allows access to the registers of clock setting; 35431: "Cancel setting the clock" – it closes the access to the registers of the clock setting without changing hours;	120

Parameter	Range of values	Initial volume	Description	Address
			40959: "Clear the internal memory of the tasks" – to erase the program for logic of actions (when the memory card is inserted, it will automatically read again).	

Table 5.7 – Parameters of unit current state

Parameter	Description	Address
Mode (see details for reg. 122)	0: User's mode 1: Mode of setting	121
Tabs of access	Bit 0 0: The connected client can not get the access (via password) on inquiry for device reading function via RS-485 1: The connected client can get the access on inquiry for reading function of the devices connected to RS-485	122
	Bit 1 0: The connected client has no access on inquiry for reading function of devices connected to RS-485 1: The connected client has an access on inquiry for reading function of the devices connected to RS-485	
	Bit 2 0: The connected client can not get an access on inquiry for functions of writing and control of devices via RS-485 1: The connected client can get an access on inquiry for functions of writing and control of devices via RS-485	
	Bit 3 0: The connected client has no access on inquiry for functions of writing and control of devices connected via RS-485 1: The connected client has an access on inquiry for functions of writing and control of devices connected via RS-485	
	Bit 4 0: The connected client can not get an access to registers EM-486, except for registers of version, password, mode and tabs of access 1: The connected client can get an access to registers EM-486, except for registers of version, password, mode and tabs of access	
	Bit 5 0: The connected client has no access to registers EM-486, except for registers of version, password, mode and tabs of access 1: The connected client has an access to registers EM-486, except for registers of version, password, mode and tabs of access	
	Bit 6 Always 1	
	Bit 7 0: the connected client has no access for EM-486 setting 1: the connected client has an access for EM-486 setting (similar to to reg. 121)	
	Bit 8 Always 0	
	Bit 9 1: client has an authority for connection (always is read as «1» after connection)	
Bit 12 0 – the connected client does not have permission to set the clock; 1 – the connected client have permission to set the clock.		
Time, min	Number of minutes since the moment of start-up	123–124
Number of Modbus TCP clients	Number of occupied connections of Modbus TCP	125
Limit of Modbus TCP clients	Total number of possible connections via Modbus TCP	126
Load of RS-485, inquiries/sec	Number of inquires sent via RS-485 per second	127

Parameter	Description	Address
Working load of RS-485, inquiries/sec	Number of replies without errors via RS-485 per second	128
Load of RS-485 per second, %	Loading of RS-485 for the last second, with taking into account set rate of RS-485 and time of inactivity	129
Load of RS-485 per minute, %	Loading of RS-485 for the last minute	130
Load of RS-485 per 5 minutes, %	Loading of RS-485 for the last five minutes	131
Load of Modbus TCP, inquiries/sec	Number of inquiries received from the clients via Modbus TCP per second	132
Useful load of Modbus TCP, Inquiries/sec	Number of replies without errors being sent to the clients via Modbus TCP per second	133
Load of GSM, kB/sec	Loading of GPRS channel with GSM being switched on	134
Load of Ethernet, ·100 kB/sec	Loading of wire channel with Ethernet being switched on	135
Max. clients of Modbus TCP	Maximal number of simultaneously connected clients via Modbus TCP – from the moment of start up	136
Max. load of Modbus TCP, inquiries/sec	Maximal number of inquiries received per second from the clients via Modbus TCP – from the moment of start up	137
Max. load of RS-485, %	Maximal loading of RS-485 for 5 minutes – from the moment of start up	138
Max. load of GSM, kB/sec	Maximal loading of GPRS – from the moment of start up	139
Current IP-address of Ethernet	IP-address, by which the device is available in Ethernet network*	140–143
Current MAC-address of Ethernet	MAC-address, by which the device is detected in Ethernet network	144–149
State of universal input 1	The readings of gauge connected to input 1, depending on the type of gauge (see register 580): -For the gauges with analogue output – the value of gauge output in mV or in μ A (depending on the type of gauge); -For discrete breakers – 0 at open contacts, 1 at closed contacts; -For temperature gauges – the measured value of temperature, 32767 – at gauge cut off, -32768 – at gauge short circuit	150
The effective value of input 1 state	The gauge readings at the input 1 given as to the user scale, in accordance to the settings (see registers 766–767).	151
State of universal input 2	The readings of the gauge connected to input 2	152
The effective value of input 2 state	The gauge readings at the input 2 given as to the user scale, in accordance to the settings	153
State of universal input 3	The readings of the gauge connected to input 3	154
The effective value of input 3 state	The gauge readings at the input 3 given as to the user scale, in accordance to the settings	155
State of universal input 4	The readings of the gauge connected to input 4	156
The effective value of input 4 state	The gauge readings at the input 4 given as to the user scale, in accordance to the settings	157
Not used parameter	The parameter is reserved for parity and is equal 0	158–159
State of relay output 1	0 – relay off, 1 – relay on	160
State of relay output 2	0 – relay off, 1 – relay on	161
State of relay output 3	0 – relay off, 1 – relay on	162
Not used parameter	The parameter is reserved for parity and is equal 0	163–164
Time before connection to remote server	0: there is a connection to server of data accumulation 1: The connection is being made to the server of data accumulation 2 – 65534: number of seconds before the repeated connection 65535: connection to server is not used	165
Number of planned restarts	Number of restarts in accordance to the user setting – for total operational time of the device	166
Number of critical errors	Number of noted errors (failures) causing the restart of the device – for total operational time of the device	167
Operation time of device, min	Number of minutes of device operation – for total operational time of the device	168–169
Current time	Number of seconds since 1st of January of specified year (see reg. 172)	170–171

Parameter	Description	Address
Year of time count	Year, since 1 st of January which is taken for time count	172
Time zone, min	Time zone, for the time count, number of minutes with sign as to UTC+00	173
Temperature, °C	Device internal temperature	174
Power voltage, mV	Bus voltage 12 V (voltage at the output of the internal power source or at inlet of backup power, depending on which the voltage is higher).	175
Time before connection to remote server Modbus TCP	0: there is a connection to remote server 1: the connection is being made to remote server 2 – 65534: number of seconds before the repeated connection 65535: connection to server is not used	176
Interface connection to remote server Modbus TCP	0 – there is a don't connection; 1 – there is a connection by Ethernet; 2 – there is a connection to GPRS.	177
Not used parameter	The parameter is reserved for parity and is equal 0	178–179
IP-address of client 1**	IP-address of client, 0.0.0.0 – not connected	180–183
Port of client 1**	Port of client, 0 – not connected	184
IP-address of client 2**	IP-address of client, 0.0.0.0 – not connected	185–188
Port of client 2**	Port of client, 0 – not connected	189
IP-address of client 3**	IP- address of client, 0.0.0.0 – not connected	190–193
Port of client 3**	Port of client, 0 – not connected	194
IP-address of client 4**	IP- address of client, 0.0.0.0 – not connected	195–198
Port of client 4**	Port of client, 0 – not connected	199
Pulse counter at input 1	Number of pulses at input 1 after starting	200 – 201
Pulse counter at input 2	Number of pulses at input 2 after starting	202 – 203
Pulse counter at input 3	Number of pulses at input 3 after starting	204 – 205
Pulse counter at input 4	Number of pulses at input 4 after starting	206 – 207
Unused parameter	Parameter is reserved for compatibility and is equal to 0.	208 – 209
Year (current time)	Current year	210
Month (current time)	Current month	211
Day of the month (current time)	Current day of the month	212
Hour (current time)	Current hour	213
Minute (current time)	Current minute	214
Second (current time)	Current second	215
Day of week (current time)	Current day of week (1 – Monday)	216
Month (winter time)	Current month, excluding summer time	217
Day of the month (winter time)	Current day of the month, excluding summer time	218
Hour (winter time)	Current hour, excluding summer time	219
Filter of the value of input 1	Last change of register 150 with a delay of 5 seconds	220
Filter of the reduced value of input 1	Last change of register 151 with a delay of 5 seconds	221
Filter of the value of input 2	Last change of register 152 with a delay of 5 seconds	222
Filter of the reduced value of input 2	Last change of register 153 with a delay of 5 seconds	223
Filter of the value of input 3	Last change of register 154 with a delay of 5 seconds	224
Filter of the reduced value of input 3	Last change of register 155 with a delay of 5 seconds	225
Filter of the value of input 4	Last change of register 156 with a delay of 5 seconds	226
Filter of the reduced value of input 4	Last change of register 157 with a delay of 5 seconds	227
Unused parameter	Parameter is reserved for compatibility and is equal to 0	228 – 229
The time of day, sec	Number of seconds from midnight of the current day	230 – 231
The time of sunrise, sec	0–86399: Number of seconds from midnight to sunrise; 86400: Sunrise is not observed in this day	232 – 233
The time of sunset, sec	-1: Sunset is not observed in this day; 0–86399: Number of seconds from midnight to sunset;	234 – 235
Unused parameter	Parameter is reserved for compatibility	236 – 269
The stored pulse counter at input 1***	Number of pulses at input 1 during operation of built-in battery of the clock	270 – 271
The stored pulse counter at input 2***	Number of pulses at input 2 during operation of built-in battery of the clock	272 – 273

Parameter	Description	Address
The stored pulse counter at input 3***	Number of pulses at input 3 during operation of built-in battery of the clock	274 – 275
The stored pulse counter at input 4***	Number of pulses at input 4 during operation of built-in battery of the clock	276 – 277
Unused parameter	Parameter is reserved for compatibility and is equal to 0	278 – 279
Operating time of the relay 1, sec***	Time in seconds during which the relay 1 is turned on (during operation of the built-in battery)	280 – 281
Operating time of the relay 2, sec***	Time in seconds during which the relay 2 is turned on (during operation of the built-in battery)	282 – 283
Operating time of the relay 3, sec***	Time in seconds during which the relay 3 is turned on (during operation of the built-in battery)	284 – 285
Unused parameter	Parameter is reserved for compatibility and is equal to 0	286 – 289
Switching-off counter of relay 1***	Switching-off number of relay 1 (during operation of the battery)	290 – 281
Switching-off counter of relay 2***	Switching-off number of relay 2 (during operation of the battery)	292 – 293
Switching-off counter of relay 3***	Switching-off number of relay 3 (during operation of the battery)	294 – 295
Unused parameter	Parameter is reserved for compatibility and is equal to 0	296 – 299
Settings	Settings are not state parameters (Table 5.8).	300 – 799
Unused parameter	Parameter is reserved for compatibility	800 – 899
Current IP-address of GSM**	IP-address obtained from GPRS* provider	900 – 903
Unused parameter	Parameter is reserved for compatibility	904 – 914
GSM signal level, %**	Signal level and quality of radio communication with GSM provider	915
Unused parameter	Parameter is reserved for compatibility	916 – 926
The type of battery connection**	Type of hardware connection of the built-in battery power (battery for real time clock): 0 – the battery powers the clock in the central controller - memory of statistics (registers 270–299, 5240–5249); 1 – the battery powers the clock in GSM module, the memory of statistics is reset to zero when power is off	927
User parameters of status	User parameters of status after starting take a value of 0. They can be used for storage and transmission to the server of tasks of values to be measured and calculated in the files, and noted events	5000 – 5239
User parameters of statistics***	They store the value for the operating time of the built-in battery for the clock. They can be used in the task files for statistics gathering or saving state	5240 – 5249

* – IP-address of device in GSM network can be allocated dynamically. For the access to the device via GSM using its IP-address, please contact the provider of GSM service.
 ** – content of registers is available only in the setting mode
 *** – not all hardware versions of the product supported saving the content of the data of registers when the external power is disabled (see register 927)

Table 5.8 – Device parameters of setting

Parameter	Range of values	Factory value	Description	Address
Ethernet network				
Static IP-address	IP-address	192.168.0.111	If the dynamic addressing is switched off or not available, IP-address of the device in Ethernet network is equal to this value	300 – 303
Sub network mask	IP-mask	255.255.255.0	It is used only with a static IP-address	304 – 307
Gateway	IP-address	192.168.0.1	It is used only with a static IP-address, or as IP filter for DHCP-server	308 – 311
Switch on the dynamic addressing with a help of DHCP-server	0–1	1	0: preset IP-address, mask and gateway is used for addressing in Ethernet. 1: DHCP network server is used by the unit to determine IP-address, mask and gateway. The parameters for static addressing are used if server is unavailable	312

Parameter	Range of values	Factory value	Description	Address
Switch on the filter of IP-address of DHCP-server	0–1	0	Used if dynamic addressing is enabled. 0: unit receives addressing data from the first DHCP-server to respond 1: unit receives addressing data only from DHCP-server with IP-address of the gateway	313
Switch on the use of server DNS with IP-address of gateway	0–1	1	It is used if DHCP is not available (switched off) 0: DNS of gateway is not used 1: DNS of gateway is used for detecting the IP-address of server for accumulating data if its address is set as host name	314
IP-address of DNS server	IP-address	8.8.8.8	It is used if DHCP is not available (switched off) When the server of DNS gateway is used, it sets IP-address of additional DNS server	315 – 318
IP-address of additional DNS server	IP-address	0.0.0.0	It is used if DHCP is not available (switched off) It can set the IP-address of one more additional DNS server. 0.0.0.0 – not used	319 – 322
Switch on a manually specified MAC-address of Ethernet	0–1	0	0: unique value for every unit, stored in the memory shall be used as a MAC-address 1: manually set value is used for MAC-address	323
Manually specified MAC-address of Ethernet	MAC-address	Unique for each device	Used if manually set MAC-address is enabled for the authentication of unit in the Ethernet network Ethernet	324 – 329
GSM network				
Pin-code of SIM -card	0–65535	65535	0–9999: this code is used for the SIM card if it demands the PIN code Other values: the code isn't used, SIM card and GSM are unavailable if the card demand a code	330
Switch on the automatic detection of APN settings	0–1	1	0: device makes GPRS connection by manually set APN parameters 1: device automatically finds a provider of GSM service by IMEI code of SIM-card	331
Activate GPRS in roaming	0–1	1	0: GPRS is blocked in roaming 1: GPRS may be used in roaming	332
Activate SMS messages sending in roaming	0–1	0	0: SMS messages can not be sent (but can be received) in roaming 1: SMS messages can be received and sent in roaming	333
Parameter is not used	0	0	Is not used; should equal 0 for compatibility	334 – 351
APN log-in of GPRS service	Line of symbols		Specified by provider of GSM service. Up to 40 symbols	352 – 391
APN password of GPRS service	Line of symbols		Specified by provider of GSM service. Up to 24 symbols	392 – 415
APN address of host	Line of symbols		Specified by provider of GSM service. Up to 34 symbols. In line there should not be any spaces	416 – 449
MODBUS TCP Clients				
Connection port via Modbus TCP	1–65535	502	Used at external connection to the device for exchange via Modbus TCP protocol	450
Enable overriding of inactive clients	0–1	1	0: connection via Modbus TCP is supported regardless of time between inquiries from a client 1: if all connections via Modbus TCP are used, a new client inquiring for a connection, can be connected instead of a client being inactive for a period which is more than a set time	451
Max. reply waiting time, sec	0 – 600 000	90	Used if the overriding of inactive client is enabled	452–453

Parameter	Range of values	Factory value	Description	Address
Enable the order for the last made connection via Modbus TCP	0–1	0	0: connection via Modbus TCP is supported regardless of connection holding time 1: If all connections via Modbus TCP are used, a new client inquiring for connection can be connected instead of the last connected client, if the time of connection holding on is more than the specified time	454
Max. time of last connection holding via Modbus TCP, ms	0 – 600 000	60 000	Used if the order for the last connection via Modbus TCP is enabled	455–456
Modbus network				
Native Modbus-identifier of the device	0–247	111	0: unit forwards all Modbus TCP requests into the Modbus network, unit registers via Modbus TCP are unavailable 1–247: units responds to Modbus TCP requests bearing the given Modbus-identifier without forwarding them to the Modbus network	457
Bit rate via RS-485, bit/sec	75 – 921 600	9 600	Used in case of data exchange between the units via RS-485, the same value for the units on the same bus-bar	458–459
Activate selection of byte format when transmitting via RS-485	0–1	1	Used in case of data exchange between the units via RS-485, the same value for all units on the same bus-bar 0: unused, byte is completed with 2 stop bits 1: Byte format is selected in register 461	460
Byte format when transmitting via RS-485	0–5	5	Is used for exchange with devices via RS-485 only if byte format selection is activated. The value for devices on the same bus-bar. 0: even ("EVEN") – 1 parity bit and 1 stop bit 1: odd ("ODD") – 1 parity bit and 1 stop bit 2: «0» ("SPACE") – 1 zero bit and 1 stop bit 3: «1» ("MARK") – 1 unit bit and 1 stop bit (similar to mode with two stop-bits) 4: "ABSENT" – no parity bit, 1 stop bit 5: "AUTO-STOP" – no parity bit, 2 stop bits in the outgoing bytes, 1 stop bit in the incoming bytes; in such a case, devices with one and two stop bits may be connected simultaneously	461
Response time from Modbus RTU, msec	0–60 000	200	Used in case of data transfer via RS-485 in RTU mode. Waiting for a response is terminated if the first byte of the response has not been received within the given time after sending the request. The response is always expected longer than time of silence between frames (time of silence depends on the bit rate and shall be equal to the time required for transmitting 3.5 bytes, or 1.75 msec for bit rate over 19200 bits/sec).	462
Enable ASCII exchange via RS-485	0–1	0	Exchange mode via RS-485, the same value for all units on the same bus-bar. 0: RTU exchange mode (format: 1 start bit, 8 data bits, 2 stop-bits, parity bit, and stop bit or only 1 stop bit – total from 10 to 11 bits). 1: ASCII exchange mode (format: 1 start bit, 7 data bits, 2 stop-bits or parity bit or stop bit – total 10 bits). In this case, the non-standard parity modes 4 (no parity bit, 1 stop bit) and 5 (stop bits automatic compatibility) are not accessible; format 3 (1 unit bit and 1 stop bit, or 2 stop bits) is used instead.	463

Parameter	Range of values	Factory value	Description	Address
Response time for subsequent Modbus ASCII character, msec	0–60 000	1000	Used in case of data transfer via RS-485 in ASCII mode. Waiting for a response is terminated if the subsequent byte of the response has not been received within the given time, as indicated for the reception of response. Waiting time shall not be less than time required for transmission of a single character (depending on the bit rate).	464
Connection to data accumulation server				
Mode of connection to the server for data accumulation	0–4	1	0: connection to server is not used 1: the device makes and holds the connection to the server via the specified connection port (port on the North side) 2: the device waits for connection from the server via the server specified connection port (port on the device side) 3: similar 1, but only via Ethernet; 4: similar 1, but only via GPRS.	465
Server connection port	0–65535	20502	Inquiry port to which is addressed a side making a connection between a device and a server (see reg. 465)	466
Time of waiting for a reply from the server, sec	0–3600	120	0: the server silence time is not limited 1–3600: max. time of server silence after which the connection will be broken and must be remade again	467
Time of waiting before the second connection to the server, sec	0–30 000	15	Connection to the server of data accumulating (used in except the mode «2»). After a loss of connection with server the next connection will be made after a specified stand-by time (after the device startup, the first connection will be made after set time – 5 sec).	468
Enable the server address by a text line	0–1	1	Used in connection to accumulating server (in except the mode «2»). 0: the connection is made to the server with a fixed IP-address set in the registers 470–473 1: connection is made to the server with a name set in the registers 474–509	469
Server IP-address	IP-address	0.0.0.0	Used in connection to the server (in except the mode «2») if the setting of server address is not activated by a text line. IP-address of remote server which supports the connection.	470–473
Server address	Symbols line	MODBUS. overvis. com	Used in connection to the server (in except the mode «2») if the setting of server address is activated by a text line. Remote server address which supports the connection. As an address there can be a line with length up to 36 symbols. There should be no spaces in the line	474–509
Security				
Specified password for access to the mode of setting	Line of symbols	11111	Used for access to the mode of setting EM-486. As a password there can be used a line with length from 5 to 10 symbols. There should be no spaces in the line	510–519
Parameter is not used	0	0	Not used, for parity it should be equal to 0	520–529
Specified pass-word for writing access via incoming SMS	Line of symbols	gap	Used for verification of incoming SMS with inquiry for writing of alarm confirmation. As a password there can be used a line with length from 3 to 10 symbols. There should be no spaces in the line	530–539

Parameter	Range of values	Factory value	Description	Address
Specified pass-word for reading access via incoming SMS	Line of symbols	gap	Used for verification of incoming SMS with inquiry for reading of alarm confirmation. As a password there can be used a line with length from 3 to 10 symbols. There should be no spaces in the line	540–549
Specified pass-word for writing access via MOD-BUS TCP in devices (in except the EM-486)	Line of symbols		Used for access to the devices connected to EM-486, for inquiry of functions of writing or control, that can change the state of these devices. As a password there can be used a line with length up to 10 symbols. There should be no spaces in the line	550–559
Specified password for reading access via Modbus	Line of symbols		Used for access to the devices connected to EM-486, for inquiry of functions of reading or for access to registers of EM-486 except for registers of version, password, mode and tags. As a password there can be used a line with length up to 10 symbols. There should be no spaces in the line	560–569
Enable the protection mode against writing via SMS	0–1	0	0: protection against writing is regulated with help of other parameters (password) 1: blocking of inquiries via SMS for function of writing	570
Enable the protection mode against reading via SMS	0–1	0	0: protection against reading is regulated with help of other parameters (password) 1: blocking of inquiries via SMS for function of reading	571
Enable the protection mode against writing via Modbus TCP	0–1	0	0: protection against writing is regulated with help of other parameters (password) or deactivated 1: blocking of any function inquiries except for functions of Modbus 1, 2, 3, 4, 7, 17, 20	572
Enable the protection mode against reading via Modbus TCP	0–1	0	0: protection against reading is regulated with help of other parameters (password) or deactivated 1: blocking of inquiries for Modbus functions 1, 2, 3, 4, 7, 17, 20, except for reading of functions of three registers of version, mode and tabs	573
Parameter is not used	0	0	Not used, for parity it should be equal to 0	574
Relay				
Normal state of relay K1	0–1	0	0– in normal state the relay is OFF 1– in normal state the relay is ON, a command for switching on the relay, deactivates it	575
Normal state of relay K2	0–1	0	0– in normal state the relay is OFF 1– in normal state the relay is ON, a command for switching on the relay, deactivates it	576
Normal state of relay K3	0–1	0	0– in normal state the relay is OFF 1– in normal state the relay is ON, a command for switching on the relay, deactivates it	577
Parameter is not used	0	0	Not used, for parity it should be equal to 0	578–579
Sensors				
Type of sensor connected to input 1	0–9	0	0: Sensor is not connected 1: Sensor with output 0–10 V 2: Sensor with output 2–10 V 3: Sensor with output 0–20 mA 4: Sensor with output 4–20 mA 5: Discrete breaker 6: Temperature NTC 2 kOhm (B=3950) 7: Temperature NTC 2,5 kOhm (B=3660) 8: Temperature NTC 2,5 kOhm (B=3980) 9: Temperature NTC 5 kOhm (B=3300)	580

Parameter	Range of values	Factory value	Description	Address
			10: Temperature NTC 5 kOhm (B=3520) 11: Temperature NTC 5 kOhm (B=3970) 12: Temperature NTC 6,8 kOhm (B=3520) 13: Temperature NTC 10 kOhm (B=3435) 14: Temperature NTC 10 kOhm (B=3650) 15: Temperature NTC 10 kOhm (B=3950) 16: Temperature NTC 15 kOhm (B=4145) 17: Temperature NTC 20 kOhm (B=4200)	
Effective minimum value for sensor of input 1	-32768 – +32767	0	For the sensor with analog output – the value of register of effective value (address 141) at minimal value of sensor output (depending on the type); For the discrete breakers – the value of the register of effective value at contacts being open; For temperature sensors – the sensor temperature values (address 140), for which the correction is made	581
Effective maximum value for sensor of input 1	-32768 – +32767	100	For the sensor with analog output – the value of register of effective value (address 141) at maximal value of sensor output (depending on the type); For the discrete breakers – the value of the register of effective value at contacts being closed; For temperature sensors – sensor corrected temperature value (address 141), at measured temperature equal to the value of register 581.	582
Presentation value of sensor 1	0–1	0	0: Measured value is presented on the display console and at the status page of WEB-interface 1: Adjusted value is presented on the display console and at the status page of WEB-interface	583
Quantity of decimal signs of adjusted value of sensor 1	0–4	0	The parameter is not used if presentation of measured value has been selected. When adjusted value is presented on the display console or at the status page of WEB-interface, this parameter indicates accuracy of the decimal fraction (position of decimal point from the right edge)	584
Annexation of a measuring unit of adjusted value of sensor 1	-24 – +24	0	The parameter is not used if presentation of measured value has been selected. When adjusted value is presented on the display console or at the status page of WEB-interface, a corresponding annex is presented after the value (0 – no annex): -24: «i» -9: «n» 1: «yes» 12: «T» -21: «z» -6: «μ» 2: «g» 15: «P» -18: «a» -3: «m» 3: «k» 18: «E» -15: «f» -2: «s» 6: «M» 21: «Z» -12: «p» -1 «d» 9: «G» 24: «l»	585
Measuring unit of effective value of sensor 1 for imaging	Line of symbols	%	The parameter is not used if presentation of measured value has been selected. When adjusted value is presented on the display console or at the status page of WEB-interface, the value a corresponding is presented after annex.	586 – 589
Type of sensor connected to input 2	0–9	0	Similar to 580	590
Effective minimum value for sensor of input 2	-32768 – +32767	0	Similar to 581	591

Parameter	Range of values	Factory value	Description	Address
Effective maximum value for sensor of input 2	-32768 – +32767	100	Similar to 582	592
Presentation value of sensor 2	0 – 1	0	Similar to 583	593
Quantity of decimal signs of adjusted value of sensor 2	0–4	0	Similar to 584	594
Annexation of a measuring unit of adjusted value of sensor 2	-24 – +24	0	Similar to 585	595
Measuring unit of effective value of sensor 2 for imaging	Line of symbols	%	Similar to 586–589	596 – 599
Type of sensor connected to input 3	0–9	0	Similar to 580	600
Effective minimum value for sensor of input 3	-32768 – +32767	0	Similar to 581	601
Effective maximum value for sensor of input 3	-32768 – +32767	100	Similar to 582	602
Presentation value of sensor 3	0 – 1	0	Similar to 583	603
Quantity of decimal signs of adjusted value of sensor 3	0–4	0	Similar to 584	604
Annexation of a measuring unit of adjusted value of sensor 3	-24 – +24	0	Similar to 585	605
Measuring unit of effective value of sensor 3 for imaging	Line of symbols	%	Similar to 586–589	606 – 609
Type of sensor connected to input 4	0–9	0	Similar to 580	610
Effective minimum value for sensor of input 4	-32768 – +32767	0	Similar to 581	611
Effective maximum value for sensor of input 4	-32768 – +32767	100	Similar to 582	612
Presentation value of sensor 4	0 – 1	0	Similar to 583	613
Quantity of decimal signs of adjusted value of sensor 4	0–4	0	Similar to 584	614
Annexation of a measuring unit of adjusted value of sensor 4	-24 – +24	0	Similar to 585	615
Measuring unit of effective value of sensor 4 for imaging	Line of symbols	%	Similar to 586–589	616–619
Parameter is not used	0	0	Not Used, for parity it should be equal to 0	620–629
Miscellaneous				
Enable periodic automatic restart of the unit	0–1	1	0: periodic restart disabled 1: unit restarts at a specified interval of time	630
Unit restart interval, min	5–7200	120	Used if periodic restart of the unit is enabled	631

Parameter	Range of values	Factory value	Description	Address
Enable the mode of automatic re-start only when there are no connections	0–1	1	Used if periodic automatic restart of the unit is enabled 0: unit restarts at a specified interval of time after startup	632
			1: unit restarts at a specified interval of time after the last transmitting via Ethernet or GSM networks	
Modbus exception code generated when there is no access	0–255	1	0: When there is no access to device Modbus registers or connected devices, the reply is not returned to the client. 1-255: When there is no access to the client sending the inquiry, this exception code is returned.	633
Modbus exception code generated when there is no reply	0–255	11	0: When there is no reply from inquiry addressee (Gateway Timeout) the reply is not returned to the client 1-255: when there is a reply from the inquiry addressee, this exception code is returned to the client	634
Switch on normally closed relays only after product complete initialization	0–1	0	0: normally closed relays are switched on immediately after product start 1: normally closed relays are switched on only after product initialization procedure (it is recommended, if relay outputs are connected with universal inputs)	635
MODBUS exception code generated if there is no connection to query addressee	0 – 255	10	0 – If there is no connection to the query addressee (Gateway Path Unavailable), response is not returned to the client; 1 – 255 – if there is no connection to the query addressee, this exception code is returned to the client;	636
Enable RS-485 slave mode	0 – 1	0	0 – Driving mode (Master). RS-485 is used to send queries; 1 – Driven mode (Slave). RS-485 is used to receive queries from additional client;	637
First MODBUS-identifier of RS-485	1 – 255	1	Parameters define a range of MODBUS identifiers used for RS-485.	638
Last MODBUS-identifier of RS-485	1 – 255	255	In the master mode the queries with addresses in this range (and also the broadcast ones with address 0) are sent via RS-485. In the slave mode the queries with addresses in this range (and also the broadcast ones and the queries to EM-486 address) are received via RS-485.	639
Connection to remote server of MODBUS TCP				
IP-address of remote server	IP-address	192.168.0.11 2	It is used when enabling redirection of queries to MODBUS TCP remote server. IP-address of the remote server wherewith connection is maintained.	640 – 643
Port of the remote server connection	0 – 65535	502	It is used during redirection of queries to the remote server. The remote server port is for MODBUS TCP connection.	644
Standby time to answer from the remote server, ms	0 – 60000	1000	It is used during redirection of queries to the remote server. After the query transfer, if the correct answer failed to be received within this time interval, answer waiting is stopped.	645
Standby time to repeated connection to the remote server, ms	0 – 240	20	It is used during redirection of queries to the remote server. After connection with the server is lost, the repeated connection will be performed after preset standby time.	646

Parameter	Range of values	Factory value	Description	Address
Remote server connection mode	0 – 4	0	0 – MODBUS TCP remote server is not used; 1 – to connect to the server using Ethernet or GPRS, preferably via Ethernet; 2 – to connect to the server using Ethernet or GPRS, preferably via GPRS;	647
			3 – to connect to the server only via Ethernet; 4 – to connect to the server only via GPRS;	
First MODBUS-identifier of the remote server	1 – 255	1	It is used during redirection of queries to the remote server. The parameters define the range of MODBUS identifiers used for RS-485. Queries with addresses in this range (and also the broadcast ones with address 0) are sent to the remote MODBUS TCP server.	648
Last MODBUS-identifier of the remote server	1 – 255	255		649
Counters				
Pulse counter mode for input 1	0–3	0	0: Counter not used 1: Pulse rising edge counter 2: Pulse falling edge counter 3: Both pulse edges counter	650
Pulse quantity in unit of time of counter 1	1– 999 999 999	8000	Used only is counter is switched on. Pulse quantity on input, after pulses are registered counter is set to one	651–652
Counter 1 maximum value	0– 999 999 999	999 999 999	Used only is counter is switched on. After counter maximum value exceeds counter is set to 0	653–654
Counter 1 maximum frequency	1– 500 000	500 000	Used only is counter is switched on. Square pulses maximum frequency on input. For pulses of other form value shall be increased	655–656
Pulse falling edge detection lower threshold for counter 1	0–100	25	Used only is counter is switched on. Falling edge start is defined when signal weakens on input at lower threshold. Threshold is set as a share from peak signal in percentages	657
Pulse rising edge detection higher threshold for counter 1	0–100	75	Used only is counter is switched on. Rising edge start is defined when signal enhances on input at higher threshold. Threshold is set as a share from peak signal in percentages	658
Parameter not used	0	0	Parameter not used, for compatibility shall be equal to 0	659
Pulse counter mode for input 2	0–3	0	Similarly 650	660
Pulse quantity in unit of time of counter 2	1– 999 999 999	8000	Similarly 651–652	661–662
Counter 2 maximum value	0– 999 999 999	999 999 999	Similarly 653–654	663–664
Counter 2 maximum frequency	1– 500 000	500 000	Similarly 655–656	665–666
Pulse falling edge detection lower threshold for counter 2	0–100	25	Similarly 657	667
Pulse rising edge detection higher threshold for counter 2	0–100	75	Similarly 658	668
Parameter not used	0	0	Parameter not used, for compatibility shall be equal to 0	669
Pulse counter mode for input 3	0–3	0	Similarly 650	670

Parameter	Range of values	Factory value	Description	Address
Pulse quantity in unit of time of counter 3	1–999 999 999	8000	Similarly 651–652	671–672
Counter 3 maximum value	0–999 999 999	999 999 999	Similarly 653–654	673–674
Counter 3 maximum frequency	1–500 000	500 000	Similarly 655–656	675–676
Pulse falling edge detection lower threshold for counter 3	0–100	25	Similarly 657	677
Pulse rising edge detection higher threshold for counter 3	0–100	75	Similarly 658	678
Parameter not used	0	0	Parameter not used, for compatibility shall be equal to 0	679
Pulse counter mode for input 4	0–3	0	Similarly 650	680
Pulse quantity in unit of time of counter 4	1–999 999 999	8000	Similarly 651–652	681–682
Counter 4 maximum value	0–999 999 999	999 999 999	Similarly 653–654	683–684
Counter 4 maximum frequency	1–500 000	500 000	Similarly 655–656	685–686
Pulse falling edge detection lower threshold for counter 4	0–100	25	Similarly 657	687
Pulse rising edge detection higher threshold for counter 4	0–100	75	Similarly 658	688
Parameter not used	0	0	Parameter not used, for compatibility shall be equal to 0	689-699
Automatic transition to daylight saving time				
Daylight saving time transition mode	0 – 200	12	0 – automatic transition is not used (the gain can be set manually when setting the clock) 1 – Brazil 6 – Italy 11 – Turkey 2 – Great Britain 7 – Namibia 12 – Namibia 3 – Germany 8 – Poland 13 – Finland 4 – Greece 9 – Portugal 14 – France 5 – Jordan 10 – USA 15 – according to preset days;	700
Preset month for transition to daylight saving time	1 – 12	3	It is used if you selected the automatic transition to daylight saving time on the specified days. The month when the clock will be set one hour ahead.	701
Preset week of the month for transition to daylight saving time	1–10	10	It is used if you selected the automatic transition to daylight saving time on the specified days. Week of the month when the clock will be set one hour ahead. 1–5 – week of the month, counting the part weeks; other values – the last week of the month;	702
Preset day of the week for transition to daylight saving time	1–7	7	It is used if you selected the automatic transition to daylight saving time on the specified days. The day of the week when the clock will be set one hour ahead.	703
Preset hour for transition to daylight saving time	0–22	2	It is used if you selected the automatic transition to daylight saving time on the specified days. The hour of the day at which the clock will be set one hour ahead.	704

Parameter	Range of values	Factory value	Description	Address
Preset month of revert to standard time	1 – 12	10	It is used if you selected the automatic transition to daylight saving time on the specified days. The month when the clock will be set one hour back.	705
Preset week of the month of revert to standard time	1–10	10	It is used if you selected the automatic transition to daylight saving time on the specified days. Week of the month when the clock will be set one hour back. 1–5 – week of the month, counting the part weeks; other values – the last week of the month;	706
Preset day of the week of revert to standard time	1–7	7	It is used if you selected the automatic transition to daylight saving time on the specified days. The day of the week when the clock will be set one hour back.	707
Preset hour of revert to standard time	1–23	3	It is used if you selected the automatic transition to daylight saving time on the specified days. The hour of the day at which the clock will be set one hour back.	708
Calculation of sunrises and sunsets				
Sunny day	0–3	1	0 – official; 1 – civil; 2 – marine; 3 – astronomical;	709
Latitude, degrees	0 – 89	46	The absolute value of the latitude.	710
Latitude, minutes	0 – 59	29		711
Latitude, seconds	0 – 59	10		712
Longitude, degrees	0 – 179	30	The absolute value of the longitude.	713
Longitude, minutes	0 – 59	43		714
Longitude, seconds	0 – 59	40		715
Quadrant	0 – 3	0	0 – N latitude, E longitude; 1 – N latitude, W longitude; 2 – S latitude, E longitude; 3 – S latitude, W longitude;	716
The connection to the server of NTP clock synchronization				
NTP server connection mode	0 – 4	0	0 – clock synchronization with the server is not used 1 – to connect to the servers using Ethernet or GPRS, preferably via Ethernet; 2 – to connect to the servers using Ethernet or GPRS, preferably via GPRS; 3 – to connect to the servers only via Ethernet; 4 – to connect to the servers only via GPRS;	717
Time period of connection to NTP servers, h	1 – 240	24	It is used if you have enabled synchronization of clocks with the server clock. The time interval over which the server time is received.	718
Minimum shift of clock for synchronization, s	1 – 180	2	It is used if you have enabled synchronization of clocks with the server clock. The synchronization is performed after receiving the server time, if the difference between the clocks is no less than this value.	719
User settings				
User's settings and stored values	0 – 65535	0	They can be used to store any identification data of the product or for adjusting the settings of task files operation.	5250-5499
Setting the clock*				
Adding daylight saving time, -15 minutes	-48 – +48		Current gain. It is set during manual transition to the daylight saving time, when selecting the automatic mode it will be adjusted within 5 minutes.	34817
Adding time zone, -15 minutes	-48 – +48	8	It is used during synchronization of the clock with the server clock.	34818

Parameter	Range of values	Factory value	Description	Address
Second	0–59		The time is to be set at the clock	34819
Minute	0–59			34820
Hour	0–23			34821
Day	1–31			34822
Month	1–12			34823
Year	0–65534			34824
Set the clock	0–65535	0	It is used to set the clock. When recording to this register with any value, the new clock settings in registers 34817-34824 will be set.	34825
* – registers for the clock setting is available only in the clock setting mode, see registers 120, 122				

5.3.3 Configuring EM-486 through WEB interface

WEB-browser is used for setting via WEB-interface.

1) Write the unit IP-address in your browser (to display address on the display of the product see section 5.3.1) and proceed to the specified address.

Note: If the browser is set to use the proxy server, the access to the unit over local network shall be granted only after adding the IP- address into the exceptions list as indicated in the browser documentation.

2) Select "Parameters" for setup of parameters. Password request shall appear before granting access to setup mode (factory setting 11111).

3) Enter password and press **ENTER**. If the password is correct, you shall be granted access to the setup mode. You will see the settings page. If the password is incorrect, the password request shall be displayed once again.

4) Settings on the settings page are grouped by types and are divided into tabs. Non-configurable settings and measurements are available in the tab "State". Settings on other tabs are listed in table 5.8.

5) Click **SAVE** after making changes to the settings. This will check all the changed parameters. If no errors is detected, new parameters will be stored in the memory (new settings will take effect after the following application of settings or restart of the product). In case of any errors detected upon clicking the **SAVE** button, none of the parameters is saved, while the names of erroneous parameters are highlighted in red.

6) To apply the settings without restarting the product, you should click "Apply" at the bottom of the page. The entered settings will be checked. If the values of the parameters have not errors, the parameters will be stored in the memory of EM-486 and will come into force. Only parameters MODBUS, inputs and outputs can be applied without restarting.

7) To set the clock on the tab "Time", press **Set** button.

8) Click **Restore defaults** to restore the default value of parameters.

9) Click **Reset** to stop all connections and interrupt all receive/transmit operations, with the following restart of the unit. In case of any changes to the parameters, either introduced or stored in the memory, these changes shall be implemented.

Note: If the addressing parameters in Ethernet network (MAC-address, IP- address) are modified and saved, the browser may not load the page after the restart of the unit by pressing the **Reset** button. This can happen as the browser continues to reply over the previous address. In this case, the connection should be made anew.

10) Clicking the **Leave** button the will close the setup mode and a password request appears once again.

5.3.4 Configuring ET-485 through Modbus interface

Setting via Modbus-interface shall be provided if the unit is connected over the Modbus client, which is supporting the Modbus TCP protocol. The connection is established using its IP-address (for display of the address on the product display see the item 5.3.1) with the indication of Modbus-identifier (factory setting - 111).

Write the password string into the password input register (see Table 5.6) before setting parameters. Factory set password – is 11111, i.e. write 49 - ASCII-code for one to record the factory set password to registers 100 – 104 (see App. B). If the password is correct, the mode register (see Table 5.7) takes the value of 1 – setup mode.

The instruction register (see Table 5.7), as well as registers for the collection of Modbus customizable parameters (see Table 5.8) are available for writing in the setup mode. When the required value is written to the registers of customizable parameters, write 2 (instruction for **Saving**) in the instruction register. The accuracy of values for the stored parameters can be checked by comparing the collections of customizable parameters and saved parameters. If collections are the same, new values and settings shall be accepted and saved.

To apply the settings without restarting the device you should write into the parameter of the control command the value "4" – command **Save and apply**. The correctness of the saved parameter values can be checked by comparing the sets of configurable parameters and current settings. If the sets match, then the new settings are accepted and saved.

To reset the saved parameters to factory settings, write 444 (instruction for **Restoring to factory**) in the instruction register.

Can be restart the unit for the saved settings to take effect. To restart via Modbus interface, write 1 (instruction for “**Restarting**”) in the instruction register.

To exit the setup mode, write 0 instead of any character in password input register. This will clear all the password input registers and instruction register (turn the values to 0).

6 MAINTENANCE

6.1 SAFETY PRECAUTIONS



THE TERMINALS AND THE PRODUCT INTERNAL ELEMENTS CONTAINS POTENTIALLY LETHAL VOLTAGE.

DURING MAINTENANCE IT IS NECESSARY TO DISABLE THE PRODUCT AND CONNECTED DEVICES FROM THE MAINS

6.2 Maintenance of the unit should be performed by persons admitted to the operation and have the appropriate permission.

6.3 The recommended frequency of maintenance is every six months.

6.4 MAINTENANCE PROCEDURE:

- 1) check the wires connection reliability, if necessary – clamp with force as specified in Table 3.1;
- 2) check visually the housing integrity;
- 3) if necessary, wipe with cloth the front panel and the unit housing.

It is not allowed to clean the unit with abrasive materials or organic compounds (alcohol, gasoline, solvents, etc.).

7 SERVICE LIFE AND WARRANTY

Service life – is 10 years. Contact manufacturer upon the expiry of the service life.

Guaranteed storage life – is 3 years.

Warranty period of the unit operation is 5 years from the date of sale.

During the warranty period the Manufacturer is responsible for free repair of the unit, if the Consumer has complied with the requirements of this Operating Manual.

ATTENTION! IF THE UNIT HAS BEEN OPERATED WITH VIOLATION OF THE REQUIREMENTS OF THIS OPERATION MANUAL, THE MANUFACTURER HAS THE RIGHT TO REFUSE WARRANTY SERVICE.

Warranty service is performed at the place of purchase or by the Manufacturer of the product.

Post-warranty service is performed by the Manufacturer at current rates.

Before sending for repair, the unit should be packed in the original or other packaging excluding mechanical damage.

8 TRANSPORTATION AND STORAGE

EM-486 in the shipping box should be stored indoors at a temperature of -45 to +60 °C and relative humidity of no more than 80% with no vapors available in the air, capable of producing harmful effect on the shipping box and unit materials.

Appendix A
(obligatory)
Versions and modifications

Table A.1 – Versions of Unit

Version	Date of modification	Remarks
1	31.08.2015	<ul style="list-style-type: none"> The demo- version
10	29.12.2015	<ul style="list-style-type: none"> Added adjustable measuring value at the universal inputs Added non-standart byte format at the RS-485 transmitting Added possibility of use of SIM cards with the PIN code
11	21.01.2016	<ul style="list-style-type: none"> Stability of operation of GSM is increased Stability of connection with the server through GPRS is increase Added the mode of the active connection to the server through any of available Ethernet or GPRS interfaces Added options of lock of GPRS and the SMS in roaming Insignificant improvements in the WEB INTERFACE
12	15.02.2016	<ul style="list-style-type: none"> Added impulse counter on inputs
13	01.03.2016	<ul style="list-style-type: none"> Stability of GSM operation is increased
14	18.03.2016	<ul style="list-style-type: none"> Improvements of reception and sending SMS managing directors
15	12.09.2016	<ul style="list-style-type: none"> Improved accuracy of real-time clock;
16	10.08.2016	<ul style="list-style-type: none"> It is added the saving of settings when upgrading firmware; It is added the ability to receive updates automatically; It is added the reading and execution of task files;
17	31.08.2016	<ul style="list-style-type: none"> It is improved the input registers support in task files; It is added the adjustment of time delays in task files;
18	16.09.2016	<ul style="list-style-type: none"> It is added the user settings field;
19	17.09.2016	<ul style="list-style-type: none"> It is improved the stability of GPRS connection; It is improved DHCP operation; Added support of flags and inputs for MODBUS in task files;
21	05.12.2016	<ul style="list-style-type: none"> Added the set of real time clock via MODBUS;
22	18.01.2017	<ul style="list-style-type: none"> Enhanced information about connections in the display; Short press "R" button is used to safely remove the memory card and to display the page of connections with the IP address; Improved speed and stability of GSM operation; Improved stability of Ethernet in busy networks; Added modes of slave via RS-485 and redirection queries to MODBUS TCP remote server; Added support for the files of the tasks of the floating-point number, rounded to the fixed-point number; Added support in the task files for non-standard MODBUS byte order parameters;
23	03.03.2017	<ul style="list-style-type: none"> Improved operation with 32-bit parameters in the task files; Improvements in the settings of the universal inputs and counters; Improved re-connection via GPRS; Added ability to work with files through WEB interface; Added the ability to synchronize the clock with server; Added the astronomical calculation of sunrise and sunset; Added ability to redirect queries via GPRS;
24	24.03.2017	<ul style="list-style-type: none"> Added automatic transition to daylight saving time; Added storing statistics in memory, powered by the battery;

Table A.2 The versions of the Unit are provided

Version	Date of modification	Remarks
1	31.08.2015	<ul style="list-style-type: none"> The demo- version
2	18.03.2016	<ul style="list-style-type: none"> Connection of the GSM module is improved Improved insulation of operating lines of relay outputs
3	12.07.2016	<ul style="list-style-type: none"> Improved accuracy of real-time clock;

Appendix B
(recommended)

Connections

NOTE! CONNECTING THE INCORRECTLY SET DEVICE TO THE DATA TRANSMITTING NETWORK CAN INFLUENCE THE COMMUNICATION BETWEEN THE OTHER DEVICES. Connection of device EM-486 to Ethernet network needs mutual parity of connected devices settings. As a rule, all connections to the network linking more than 2 devices, should be made by qualified personal (network admin).

1. IP-ADDRESSING

When units are communicating over Ethernet network using TCP/IP protocol, every unit is using a set of IP-addressing settings to identify the sender and receiver of the data. The unit memory contains a personal and unique, within a single subnet, IP-address (four bytes are written as four integers, separated by dots, in the range of 0-255), subnet mask, which is the same for all units within the subnet (written similar to IP-address), and IP-address of the gateway, which is used to communicate with other networks. Proper communication between units of a subnet is possible under several conditions:

- 1) All units of a subnet have similar to mask. Most of small LANs are using 255.255.255.0 mask.
- 2) Mask starts with a group of bits set to 1, followed by a group of bits turned to 0.
- 3) All bits set to 1 in the mask are similar to for all the IP-addresses of units in subnet and indicate the subnet address. 192.168 is most frequently used address in LANs for the mask 255.255.255.0. The third byte may be used as a subnet number in a complex LAN. In smaller LANs, the third byte is usually equal to 0.
- 4) A set of bits in IP-address of the unit, which is set to 0 in the mask, is unique to each unit within the same subnet .
- 5) In most cases, the unit like router, which is already communicating with other networks, is switched to the network. This unit often gets the following address 192.168.0.1, 192.168.0.100, or 192.168.0.101. In this case, other units in the network shall have this IP-address of the unit as the gateway address. This address is not necessary for communication between units in a subnet, and is only used to connect units of one subnet to units of other networks.

Factory addressing settings for EM-486 Interface Converter are listed in table B.1.

Table B.1 – Factory settings for EM-486 addressing

Parameter	Value
Addressing using DHCP	Yes
IP-address	192.168.0.111
Subnet mask	255.255.255.0
Gateway	192.168.0.1

Which is set to EM-486 factory settings, for communication with it via Ethernet there are 2 possible ways:

a) The network uses a router or other DHCP server, which assigns IP addresses to new devices. In this case, it is sufficient to connect the EM-486 to the network, and after some time the obtained IP address is appeared on the display. The address "0.0.0.0" means that the desired value has not been received yet. The address is "192.168.0.111", obtained after 30-60 seconds after running EM-486, may mean that getting address from the DHCP server is failed and the product uses a static address;

b) The network is not able to use DHCP, or EM-486 is connected directly to the computer (or other device-client on the same subnet). In this case, EM-486 will switch to static addressing after some time (30-60 seconds) after starting. A client device should use a mask 255.255.255.0 as a mask and address starting with 192.168.0. The fourth byte of the address can take any value in the range from 1 to 255, except for 111. If the connection between EM-486 and a client unit is not provided directly but via a network with a number of units, the mentioned address can not be equal to any of the addresses of other units on the subnet. If network has several units with the mask and the first three bytes of the IP- address, which are different from those specified in Table B.1, or the EM-486 factory IP-address is already taken, the configurable unit should be temporarily removed from the network to avoid addressing conflicts and establish a communication between this unit and EM-486 directly. This will allow configuring the unit and EM-486 for direct communication or switching EM-486 to the network.

2. CONFIGURING THE CLIENT UNIT

The unit addressing is set according to documents and software it uses.

Below is an example of configuring the personal computer (PC) on Windows XP or Windows 7 to communicate directly with the EM-486 on factory settings.

Open the list of OS network connections to configure the network address in Windows. To do this, follow the steps below (mind the OS version):

• **For Windows XP:**

- 1) Log in as administrator. 2) Select Start-Control Panel.
- 3) If control panel items are divided into categories, select "Network and Internet Connections". 4) Go to "Network Connections".

• **For Windows 7:**

- 1) Log in as administrator. 2) Select Start-Control Panel.
- 3) If control panel items are divided into categories, select "Network and Internet".
- 4) Go to "Control Center Network and Sharing Center". 5) In the task bar (on the left), select "Change adapter settings".

Next, perform the following steps:

- 1) In the Connections window, select the desired connection via an adapter with the addressing that you want to change.

Many computers have only one adapter and one connection, which will be displayed in this window. If the window shows several connections, select the connection you want, using the adapter name in the information on connection or contact your system administrator.

2) Click the icon of the connection with the right button, and select "Properties" in the drop-down menu. The Properties window opens (see Fig. B.1).

3) Select "Internet Protocol (TCP/IP)" from the list of connection components in the next window. Make sure that the component is enabled (flagged in the list). Click "Properties". The TCP/IP properties window opens (see Fig. B.2).

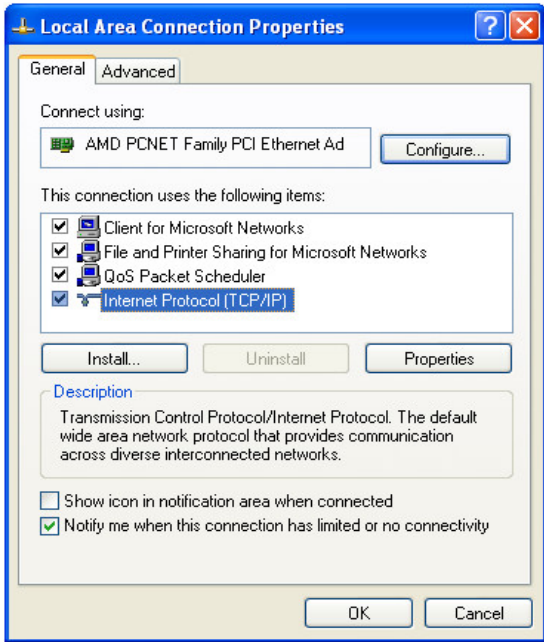

Figure B.1 – Connection properties window in Windows OS

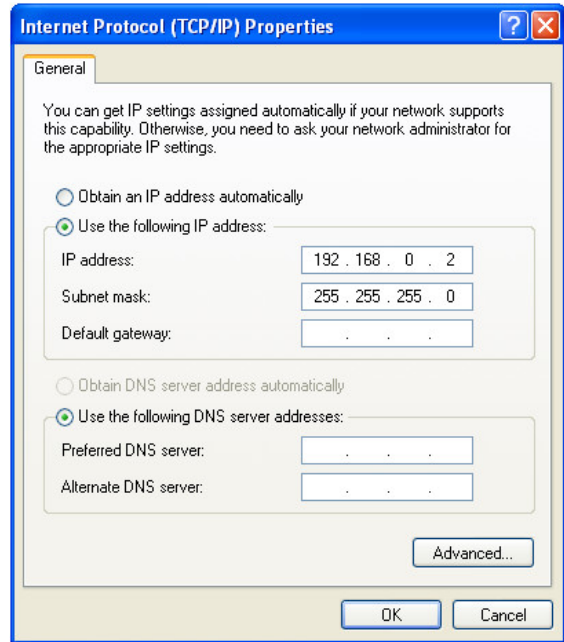

Figure B.2 – TCP/IP properties window in Windows OS

4) Select "Use the following IP- address".

5) Specify the address in the "IP- address" field within the range from 192.168.0.1 to 192.168.0.255 (except for 192.168.0.111, which is used by EM-486).

6) Specify "255.255.255.0" in the "Subnet Mask" field.

7) The fields "Default Gateway", "Preferred DNS-server", and "Alternative DNS- server" should be left blank.

8) Press "OK" to close the Protocol Settings window.

9) Press "OK" to close the Connections Settings window.

10) If prompted by the OS to restart the PC after closing the windows, answer yes.

3. CONNECTION TO INTERNET VIA ETHERNET

WARNING! The user is strongly recommended to connect the unit to Internet under the supervision of the LAN system administrator and/or representative of Internet service provider.

Use the following guidelines to connect the unit to Internet:

- Acquire a dedicated line with a static IP-address from your Internet Service Provider (hereinafter referred to as ISP);
- If static IP is unavailable, a part of functions (direct connection via MODBUS TCP or via the WEB interface) can be unavailable from Internet, at the same time connection to the server can be used;
- Direct connection of the unit to the ISP cable is not recommended; in case of a router connection, the ISP cable is connected to the "Uplink" socket on the router (It is usually marked with color and has no numbers. The marking depends on the router manufacturer, see the router documentation). The straight-through (supplied) Ethernet cable is used for connecting unit to the router. Set the router for Internet connection as per ISP recommendations. The router settings should also provide for the redirection of requests, which are coming to static IP-address provided by the ISP, to the unit IP-address (factory setting - 192.168.0.111). If for a dedicated line the static IP address is fixed in Internet, and direct access from Internet to the product FTP, HTTP, MODBUS TCP servers is required, then in settings it is required to specify ports of redirection – for a local IP address of a product on which there is a redirection, it is necessary to specify 80 (for access to the WEB INTERFACE), 502 (for access on MODBUS TCP), 21 and 2021 (for access on FTP). It will also necessary to disable DHCP in the settings of EM-486, or configuring the router for the provision of EM-486 via DHCP of always the same IP address;
- verify if the Internet connection is protected by standard means (see below);
- when referring the unit via Internet, use IP-address provided by your ISP.

4. GSM CONNECTION

WARNING! The user is strongly recommended to connect the unit to Internet under the supervision of the LAN system administrator and/or representative of Internet and mobile service providers.

Note – make sure that your tariff plan includes providing GPRS service (for connection to Internet) and/or receiving and sending SMS messages (for control via SMS).

To connect the device via GSM use the following recommendations:

- From GSM provider (next in the text as a provider) you should get a SIM-card;

- Insert the SIM-card in the device and connect the appropriate antenna to have a proper radio signal in the place of the device location;
- After starting the device, make sure that SIM-card has a correctly identification – after the communication initialization, the indicator GSM keeps on blinking; if the indicator lights down, check the SIM-card, antenna and a level of GSM signal on the display of the device;
- If GPRS is used for Internet connection, make sure, that the provider and GPRS settings are correct via code of SIM-card – after GPRS initialization, the GSM indicator is blinks 3 times per second; if the indicator is linking less frequently than 1 time per a second, check the settings of APN and GPRS;
- In case of necessity, manually set the APN in accordance with the provider’s recommendations;

5. PROTECTION OF CONNECTION

- EM-486 has basic protection against unauthorized access over network;
- Access for writing and/or reading via Modbus TCP or via SMS can be deactivated in settings;
- unit settings can be changed remotely by entering the password (minimum 5 characters). Entering several incorrect passwords while trying to determine the correct one is blocked by the unit;
- access passwords can be set for restriction of writing and/or reading via Modbus TCP or via SMS;
- when entering the password, all settings shall be only available to a given client using a given protocol. In case of no requests from the client over the long period, the access returns to locked mode;

NOTE! AT ANY CONNECTIONS EXCEPT FOR TRANSMITTING VIA GSM AND COMMUNICATION WITH SERVER VIA SPECIAL PROTOCOL EM-486, THE PASSWORDS ARE SENT IN NOT PROTECTED MODE, IN CASE OF CORRECT PASSWORD THE ACCESS OPENS IN NOT PROTECTED CONNECTION!

- The unit protection system is not designed to counter malicious network attacks (especially those, which are not trying to get access to the unit but to block it instead);
- In case of complex and large networks (especially when providing access to the ET-485 via Internet), the users are recommended to separate the unit from unprotected networks with standard protective equipment (router, configured to filter the transmissions, Firewall, etc.).

6. CONNECTION TO SERVER

EM-486 has the mode of constant communication with the data collection and management server. Data collected by the product is transferred and accumulate on the server, this data can accumulate in the internal memory of the product when connection is failed and transmitted to the server when connection is restored.

As a server there can be, for example, system Overvis (Internet-address is «overvis.com»).

Overvis – it is a system for monitoring and remote control of technological processes. Overvis makes it possible to read the data and make control over the devices including EM-486, provided there is a connection with them, to save the data in the base, review the data in appropriate form, to receive alarm messages as SMS or E-Mail.

EM-486 factory settings are prepared for connection to Overvis.

Overvis system supports a special manner of identification which is used in EM-486. Thereat the devices are verified by a unique MAC-address which is sent to the server at each connection session. The product registration for a user of the Overvis system is possible in two ways:

- a) if the device has a sticker with a QR code – it is required to read the code and follow the link and follow the instructions of the server;
- b) by specifying the activation code to a user account of Overvis. The code represents the number of 8 characters and is displayed on the display and on the status page of the WEB interface of the product after connecting to the server. When you enter code EM-486 is "attached" to a user account.

To connect a new product to the Overvis system using activation code you should:

- connect the unit to Internet via one of above mentioned methods;
- make sure (by information on the display or on the page of parameters of the unit WEB-interface state) that the connection to the server is made and the activation code is received;

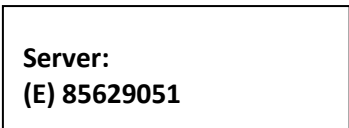

Note – if for a new devise which is connected to Overvis system there is an information that the connection is activated, then for security reason you should press the button «Restart the activation» in the page bottom of WEB-interface state page – in order to delete the device from Overvis system. That guarantees that the device will be used only by the authorized users

Figure B.3 – Image of the activation code on the display (E-connection to server via Ethernet)

- Using the instruction on the site of Overvis system, connect to EM-486 with activation code; after activation during the connection to the server there will be shown on the unit display a message «activated»;

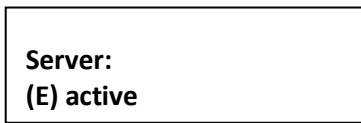

Figure B.4 – Display Image of activation state

For information about EM-486 connection to other servers, contact the Unit manufacturer.

Operation logic programming

1 General

After running, EM-486 starts execution of the program for logic of action, if it was placed earlier in the built-in memory. If there is no program in the built-in memory, EM-486 searches for and checks the task files placed in the folder "TASKS" on the memory card, provided the card is formatted in the FAT or FAT32 format. The correctly discovered files are read in the built-in memory and form the logic program of actions. Such a reading runs once after startup or after installing a new memory card, only if the built-in memory does not contain the programs.

To clean the internal memory you should:

- 1) Enter EM-486 parameter setting via WEB interface (see Manual, para 5.3.3);
- 2) Go to the tab "Files";
- 3) Press the button "Clear built-in tasks memory";
- 4) If the result of the reading the program is not displayed immediately in the tab "Files", refresh the page a few seconds later.

Note – the program in the internal memory is deleted when updating the firmware. If the memory card with the task files remains installed in the EM-486, the program will automatically read again after the update.

The tab "Files" indicates the result of reading the folder "TASKS", including the number of discovered and read files. If during reading and verifying the program errors were detected, then it indicates the type of error, file and line number of the file error. If the program consisted of several files in the folder "TASKS", then the internal memory will read all files except those in which errors are detected. Therefore, during error correction you should compare the number of discovered and read files and if some were read, to clear again the internal memory to re-read the program.

Files can have arbitrary names and extensions and placed in subfolders of the folder "TASKS". Files placed directly in the folder TASKS, allow you to use MODBUS ID default in the text, equal to MODBUS ID of the product EM-486. Files placed in subfolders in the folder "TASKS" with names from "1" to "247", allow to use in them MODBUS ID default name of the subfolder. Therefore, if the program logic is divided into tasks so that each is associated with its connected device, it is recommended that files relating only to EM-486, to be placed in the folder "TASKS" and files related to primarily the other device, to be put in a subfolder with the name of the MODBUS ID of this device. This allows you to change the list of managed devices by copying and renaming the subfolders, and create universal and portable files of the tasks.

2 Files of the tasks

File of tasks describes repeated after a specified time interval the set of actions for gathering, processing and comparing the data and special actions after fulfillment of the preset conditions according to the processing results.

The task file is divided into sections which in turn are divided into lines.

The section is part of the file that starts with "!" and the name of the section written in a row.

Correct example:

```
!META
UPDATE 60
!PARAMS
...
```

Incorrect example:

```
META
UPDATE 60
PARAMS
...
```

If the section allows you to refer the lines in it, then all the lines of the section are numbered, otherwise instead of a number of the line will be put the sign "*". The format of the line is different in each section. The number and order of sections does not matter (sections can be interrupted and then be continued after one or more sections), if two rules are fulfilled:

- 1) If a section with numbered lines is found for the first time, the numbering starts with 0, otherwise, numbering continues from the previous section of the same name.

Correct example:

```
...
!VARS
0 VAL 0
!CONDS
0 VAREQVAL V0 0
!ACTS
0 RELAYON 1 2
1 RELAYOFF 1 2
!REACTS
* C0 ACT A0
!CONDS
1 NOT C0
!REACTS
* C1 ACT A1
```

Incorrect example:

```
...
!VARS
0 VAL 0
!CONDS
0 VAREQVAL V0 0
!ACTS
0 RELAYON 1 2
1 RELAYOFF 1 2
!REACTS
* C0 ACT A0
!CONDS
0 NOT C0
!REACTS
* C1 ACT A1
```

...
2) Link to next line should be below the line that is referenced.

Correct example:

```
...
!CONDS
0 VAREQVAL V0 0
1 NOT C0
...
```

Incorrect example:

```
...
!CONDS
0 NOT C1
1 VAREQVAL V0 0
...
```

The file should end with an empty line or a comment. The file should not have extra spaces, including at the end of lines. The file can contain comment lines that begin with “#”, and are ignored when reading the file.

Correct example:

```
...
# this is comment

!VARS
# number of seconds in a minute
0 VAL 60
1 VAL 1
...
```

Incorrect example:

```
...
# this is comment

!VARS
0 VAL 60 # number of seconds in a minute
1 VAL 1
...
```

Table C.1 – Sections assignment

META	General information and the file run settings
DEVICES	MODBUS devices capabilities
PARAMS	Parameters, registers and bits of MODBUS devices, and type conversion
VARs	Variables, transformation of parameters and calculations
PHONES	Phone numbers to which SMS are sent
STRs	Texts of messages to send to SMS
CONDS	Comparison of variables, the conditions for performing actions
ACTs	Actions that can be performed
REACTs	Reactions that determine under what conditions you will run the actions

2.1 META Section

It contains the general information about the file and settings for its execution, and is responsible for the particularities of the program cycle fulfillment (the so-called "updates"), including the frequency of updates. Lines in it do not have numbering, instead of index is "*". Each line has the following format:

* <modifier type> <argument>

The types of the arguments are the following:

- <int> - 32-bit signed integer
- <uchar> - 8-bit unsigned integer
- <ushort> - 16-bit unsigned integer

Table C.2 – Types of modifiers

PROTOCOLVERSION <int>	Version of the file: It prevents the processing of files with outdated firmware EM-486. The version described in this document is 5.
UPDATE <int>	Frequency of the program cycle fulfillment (update rate) in seconds: Every cycle has the reading of parameters, calculation of variables values, defining operation conditions and implementation of response to these conditions. The minimum value is 1 second. By default, if a modifier is not specified, it equals to 60.
PARAMACTUAL <ushort>	Frequency of reading the parameters in seconds: It allows optimizing the number of readings of parameters. At the moment of the updating the parameter it is checked how many seconds ago it was read last time, and if this time is not more than the value PARAMACTUAL, then upgrade option will not be read and the last read value of the parameter will be accepted as current one. Thus, if the total program consists of several files, reading the same parameters, the number of readings of these parameters and the excessive load on the communication channels can be reduced. For the value 0 – with each update the parameter values will be read again. By default, if a modifier is not specified, it equals to 0.
PARAMRETRIES <uchar>	Number of times to repeat reading in case of error: The value 0 for the programming cycle there will not be more than one attempt to read the parameter. For 1 – it will be made up to two attempts to read, etc. Calculations and reaction to conditions can be performed even without a successful reading of all parameters, if they have sufficient known data.

	By default, if a modifier is not specified, it equals to 0.
PARAMTIMEOUT <int>	Time of waiting for response to MODBUS query in milliseconds: It is used if in the settings of EM-486 the total timeout MODBUS is more than frequency of update of this file, or if the exception code generation is disabled if no MODBUS response. By default, if a modifier is not specified, it equals to 1000.
PARAMLOADRATIO <uchar>	Maximum load of RS-485 channel, in percent: After each query a delay is added, depending on the waiting time of the last response that allows other clients to send queries and receive responses. A value of 100 generates the minimum possible delays (it is not recommended). A value of 50 means a delay equal to the time of waiting for a response. A value of 25 means a delay of 3 times exceeding the response time. By default, if a modifier is not specified, it equals to 25.

Example:

```
!META
* PROTOCOLVERSION 5
* UPDATE 5
* PARAMRETRIES 2
```

2.2 DEVICES Section

It contains the capabilities of MODBUS devices, the settings of not specified here devices will be treated the same as for the device with maximum features and functions. The lines in this section do not have numbering, instead of an index is "***". Each line has the following format:

```
* <MODBUS ID of device> <record type> <argument 1> [argument 2]
```

MODBUS device ID: a number from 1 to 247. "0" – is the broadcast, it can be used to configure recording simultaneously to all devices that support the broadcasting (the argument 1 in this case is defined, but not used). "*" instead of the MODBUS ID means a device by default for this folder (EM-486, if the file is placed directly in the program folder, or device with the MODBUS ID of the name of the subfolder, if the file is placed in the subfolder named "1" to "247").

Lines with different types or arguments, but with the same MODBUS ID are not permitted. These lines being in different files in the folder of programs are also considered to be incorrect.

Arguments type: <uchar> – 8-bit unsigned integer.

Table C.3 – Types of records

WRHANY <uchar> <uchar>	Device can write both as a function of 6 and function of 16 in the storage registers. The first argument specifies how many registers can be read in one query; the second one determines how many you can record in a single query.
WRHMULTIPLE <uchar> <uchar>	Device can write only using function 16 in the storage registers. The first argument specifies how many registers can be read in one query; the second one determines how many you can record in a single query.
WRHSINGLE <uchar>	Device can write only using function 6 in the single storage register. The argument specifies how many registers can be read in one query.
WRHDENIED <uchar>	Device can't write to the storage registers. The argument specifies how many registers can be read in one query.

Example:

```
!DEVICES
* * WRHANY 50 50
* 3 WRHSINGLE 4
```

2.3 PARAMS Section

It contains parameters, their addressing, and conversion between types (how they are used by the device). When reading the settings are always converted from the specified type to the default type for the program EM-486 (INT32 – 32-bit signed integer). When recording the inverse transform is performed. The lines in this section are in ascending order, starting from zero. Each line has the following format:

```
<index> <MODBUS ID of device> <data type> <register table> <address>
```

Index: the sequential number of the line.

MODBUS ID of device: a number from 1 to 247. "0" – is the broadcast, it can be used for writing only. "*" instead of the MODBUS ID means a device by default for this folder (EM-486, if the file is placed directly in the program folder, or device with the MODBUS ID of the name of the subfolder, if the file is placed in the subfolder named "1" to "247").

Tables of registers:

- H - storage registers (most frequently used registers);
- I - input registers;

- D - digital inputs;
- C – flags;

Address: a number from 0 to 65535.

Table C.4 – Data types

UINT16	16-bit unsigned integer. It occupies one register
INT16	16-bit signed integer.
INT16BLE	16-bit signed integer with reverse order of byte transfer.
INT32	32-bit signed integer. It occupies 2 registers.
INT32BLE	32-bit signed integer with reverse order of bytes.
INT32WLE	32-bit signed integer with reverse order of words.
BIT	1-bit value for the digital inputs and flags.
INT32BE	32-bit signed integer. For compatibility, the analog to INT32.
F32EP0R	32-bit rounded to an integer with floating point.
F32EP1R	32-bit with floating-point, multiplied by 10, rounded.
F32EP2R	32-bit with floating-point, multiplied by 100, rounded.
F32EP3R	32-bit with floating-point, multiplied by 1000, rounded.
F32BLEEP0R	32-bit with reverse order of bytes and floating-point.
F32BLEEP1R	32-bit with reverse order of bytes and floating-point *10.
F32BLEEP2R	32-bit with reverse order of bytes and floating-point *100.
F32BLEEP3R	32-bit with reverse order of bytes and floating-point *1000.
F32WLEEP0R	32-bit with reverse order of words and floating-point.
F32WLEEP1R	32-bit with reverse order of words and floating-point *10.
F32WLEEP2R	32-bit with reverse order of words and floating-point *100.
F32WLEEP3R	32-bit with reverse order of words and floating-point *1000.

Example:

```
!PARAMS
0 3 UINT16 H 240
```

2.4 VARS Section

It contains variables, processing the parameters and other calculations (e.g. the sum of the parameters). The lines in this section are in ascending order, starting from zero. Each line has the following format:

```
<index> <source type> <argument 1> [argument 2]
```

Index: the sequential number of the line.

The types of the arguments:

- **<bit number>** - is the bit number of the parameter from 0 and above. For 16-bit parameters it is no more than 15. For 32-bit parameters it is not more than 31.
- **<int>** - 32-bit signed integer
- **<param ref>** - parameter reference of format Pn, where n is index of the parameter;
- **<var ref>** - variable reference of format Vn, where n is index of the variable;

Table C.5 – Types of sources

COPY <var ref>	Copy the variable.
VAL <int>	Set to the specified value.
PARAMVAL <param ref>	Copy the value of the parameter.
PARAMBIT <param ref> <bit number>	Copy one bit of the parameter value.
PARAMERC <param ref>	Copy the last error code of MODBUS parameter.
PARAMERN <param ref>	Copy the error counter of reading the parameter (it is reset to 0 after successful reading, and is incremented by 1 after each update, for which read attempts of the parameter was terminated).
VARADDVAR <var ref> <var ref>	Sum of two variables
VARMULVAR <var ref> <var ref>	Product of two variables
VARSUBVAR <var ref> <var ref>	Difference of two variables
VARDIVVAR <var ref> <var ref>	Quotient of two variables (the remainder is discarded).

Example:

```
!VARS
0 PARAMBIT P0 0
```

2.5 STRS Section

It contains the text used as message for actions. The lines in this section are in ascending order, starting from zero. Each line has the following format:

`<index> <text>`

Index: the sequential number of the line.

Special sequences in the line text:

- `*U*` - MODBUS ID by default;
- `*<var ref>*` - variable reference, such as `*V2*`;
- `**` - means a single character `*`.

Example:

```
!STRS
0 *U* - alarm 21: TS2 short circuit
```

2.6 PHONES Section

It contains texts that are used for addressing SMS. The lines in this section are in ascending order, starting from zero. Each line has the following format:

`<index> <text(phone number)>`

Index: the sequential number of the line.

Example:

```
!PHONES
# Smith - comment
0 0671234566
```

2.7 CONDS Section

It contains texts that are used for addressing SMS. The lines in this section are in ascending order, starting from zero. Each line has the following format:

`<index> <condition type> <argument 1> [argument 2]`

Index: the sequential number of the line.

The types of the arguments:

- `<int>` - 32-bit signed integer;
- `<cond ref>` - reference to the condition of the format Cn, where n is the index of conditions;
- `<var ref>` - reference to the variable of format Vn, where n is the index of the variable.

Table B.6 – Condition types

IF <cond ref>	Copy of the condition.
NOT <cond ref>	Logical NOT. The condition is satisfied, when the referred condition did not happen and vice versa.
AND <cond ref> <cond ref>	Logical AND. Condition is satisfied, when both referred conditions happened.
OR <cond ref> <cond ref>	Logical OR. The condition is satisfied, when any referred conditions occurred.
VAREQVAR <var ref> <var ref>	Comparison of two variables. The condition is fulfilled, if they are equal.
VAREQVAL <var ref> <int>	Comparison of a variable with a specified value. The condition is fulfilled when a variable by reference is equal to the specified value.
VARGRVAR <var ref> <var ref>	Comparison of two variables. The condition is fulfilled when the first variable by reference is more than the second variable.
VARGRVAL <var ref> <int>	Comparison of a variable with a specified value. The condition is fulfilled when a variable by reference is more than the specified value.
VARGEVAR <var ref> <var ref>	Comparison of two variables. The condition is fulfilled when the first variable by reference is more or equal to the second variable.
VARGEVAL <var ref> <int>	Comparison of a variable with a specified value. The condition is fulfilled when a variable by reference is more or equal to the specified value.

Example:

```
!CONDS
0 VAREQVAL V0 1
1 NOT C0
```

2.8 ACTS Section

It contains actions that can be performed (action is performed only by references from the section of the reactions **REACTS**, during the performance of the conditions indicated there). The lines in this section are in ascending order, starting from zero. Each line has the following format:

`<index> <action type> <argument 1> [argument 2]`

Index: the sequential number of the line.

The types of the arguments:

- `<int>` - 32-bit signed integer;
- `<alarm reason>` - is the number of causes of the accident – when any of the accidents is enabled, red LED of accident is on, so to turn off the indicator, each of them needs to be turned off;
- `<relay reason>` - is the number of reason to enable the relay; the relay may be on for reasons with different numbers, and remains in the active state until all causes for this relay will not be switched off;
- `<relay number>` - is the number of relay, it can be 1, 2 or 3;
- `<param ref>` - reference to the parameter of format Pn, where n is the index of the parameter;
- `<phone ref>` - reference to the phone of format Hn, where n is the index of the phone;
- `<str ref>` - reference to the line of format Cn, where n is the index of the line;
- `<var ref>` - reference to variable of format Vn, where n is the index of the variable.

Table B.7 – Types of action

ALARMON <alarm reason>	Turn on alarm LED. Red LED alarm will be on to the action of ALARMOFF with the same number of <alarm reason>.
ALARMOFF <alarm reason>	Turn off alarm LED.
RELAYON <relay reason> <relay number>	Turn on the relay. Hold the relay on up to the action of RELAYOFF with the same number of <relay reason>.
RELAYOFF <relay reason> <relay number>	Turn off the relay.
PARAMWRVAR <param ref> <var ref>	Record the parameter with the value of the variable.
PARAMWRVAL <param ref> <int>	Record the parameter with the set value.
SENDSMS <phone ref> <str ref>	Send SMS.

Example:

```
!ACTS
0 RELAYON 5 1
1 PARAMWRVAL P0 31
```

2.9 REACTS Section

It contains the responses, a list of actions that must be performed under specified conditions. Lines do not have numbering, instead of an index is “*”. Each line has the following format:

`* <cond ref> <response type> <act ref>`

The types of the arguments:

- `<cond ref>` - reference to the condition of the format Cn, where n is the index of the condition;
- `<act ref>` - reference to the action of format An, where n is the index of the action.

Table B.8 – Types of response

<cond ref> ACT <act ref>	Perform once. If the condition occurred, but did not occur in the previous update, the action will be performed once.
<cond ref> REPEAT <act ref>	Perform each time. Regardless of the previous state, the action will be executed. The action will be executed even, if the state conditions are not defined in this update due to reading errors, but this condition has already happened earlier.

Example:

```
!REACTS
* C0 ACT A0
* C1 REPEAT A1
```

3 Examples of programs

Below there are examples of finished programs, each consists of a single task file. To run the sample on the EM-486 it is necessary:

- 1) Create a text file (with the extension ".txt") and program text.
- 2) Place the file in the folder "TASKS".
- 3) Put the prepared folder on the memory microSD card, formatted in FAT or FAT32.
- 4) Put the memory card in the EM-486.

3.1 Example 1

This example describes a program that in the event of fault of the OM-310 will turn on the 1st relay on EM-486. In the text 3 – MODBUS ID of the device is OM-310; 240 is the register address which is monitored for the accident.

```
# enabling relay 1 depending on bit 0 of register 240 of device 3

!META
#5th version of Protocol
* PROTOCOLVERSION 5
# program run will be fulfilled every 3 seconds
* UPDATE 3
# in case of error of the parameter reading, it will be read again 2 times
* PARAMRETRIES 2
# limit of response waiting for MODBUS query is 1000 msec = 1 sec
* PARAMTIMEOUT 1000
# after each query the delay is added, equal to the response waiting time,
# so the other clients can perform their queries
* PARAMLOADRATIO 50

!DEVICES
# EM-486 can read and record no less than 120 registers per one query
# note the second character * - it is MODBUS ID of the EM-486 device
* * WRHANY 120 120
# OM-310 has MODBUS ID equal to 3 and allows reading 4 registers per one query,
# but to record only one register per one query
* 3 WRHSINGLE 4

!PARAMS
# during each updating, it is required to read the storage register with address 240,
# from the device with MODBUS ID equal to 3
# UINT16 - means that the 16-bit value and unsigned one (it can't be less than 0)
0 3 UINT16 H 240

!VARS
# copy zero bit of the register 240
# now in the variable the parameter value is 240.0
0 PARAMBIT P0 0

!CONDS
# variable V0 is compared with 1, condition is met, if V0 = 1
0 VAREQVAL V0 1
# condition is met, if the previous condition is not fulfilled and vice versa
1 NOT C0

!ACTS
# enable the first relay, the second unit is the number of the relay
0 RELAYON 1 1
# disable the first relay
1 RELAYOFF 1 1

!REACTS
# if C0 condition is fulfilled (if 240.0 = 1), then hold the relay 1 enabled
* C0 REPEAT A0
# if C1 condition is fulfilled (if 240.0 is not equal to 1), then the relay 1 is disabled
* C1 REPEAT A1
# END - comment at the end of the file for correct reading
```

3.2 Example 2

In this example, the program controls the hysteresis value on the second channel of the TR-101 device, depending on the temperature on the sensor of the first input of EM-486. In the text 16 – MODBUS ID of the device is TR-101; 47 is the address of register for the hysteresis of the second channel TP-101.

The program uses registers in the field of current user settings 5500-5749. Registers 5500 and 5501 are reserved for the values respectively of the lower and upper temperature limits and the registers 5502 and 5503 are for the hysteresis value to be set in TR-101 if achieving the temperature respectively the lower or upper limits. These registers are read-

only. To change them, you should be in configuration mode (see para. 5.3.4), then write the desired values to addresses of the respective editable settings. These addresses are obtained by subtracting 250 from the address current value. Thus, temperature limits are recoded into the registers 5250 and 5251, and the hysteresis – 5252 and 5253. Then, in order for the changes to take effect, you need to give the commands "Save" and "Apply" (for example by writing 4 to the register 120).

```
!META
* PROTOCOLVERSION 5
# program will run every 20 seconds
* UPDATE 20
* PARAMACTUAL 0
* PARAMLOADRATIO 50

!DEVICES
* * WRHANY 120 120
# TP-101 has MODBUS ID as 16 and can read no less than 100 registers per a query,
# but to record by one register per one query
* 16 WRHSINGLE 100

!PARAMS
# INT16 - registers with sign, as the temperature can be less than 0
0 * INT16 H 5500
1 * INT16 H 5501
# UINT16 - as the hysteresis is no less than 0
2 * UINT16 H 5502
3 * UINT16 H 5503
4 * INT16 H 150
5 16 UINT16 H 47

!VARS
# lower temperature limit
0 PARAMVAL P0
# upper temperature limit
1 PARAMVAL P1
# hysteresis for temperature below the lower limit
2 PARAMVAL P2
# hysteresis for temperature above the upper limit
3 PARAMVAL P3
# temperature value
4 PARAMVAL P4
# hysteresis value
5 PARAMVAL P5

!CONDS
# is the temperature higher than the upper limit?
0 VARGEVAR V4 V1
# is hysteresis set for the desired value for the upper limit?
1 VAREQVAR V5 V3
2 NOT C1
# if temperature is higher than limit, and hysteresis is not set to the desired value
3 AND C0 C2
# is temperature below the lower limit?
4 VARGEVAR V0 V4
# is hysteresis set for the desired value for the lower limit?
5 VAREQVAR V5 V2
6 NOT C5
# if temperature is below the limit and hysteresis is not set to the desired value
7 AND C4 C6

!ACTS
# record to TP-101 the hysteresis for temperature above the upper limit
0 PARAMWRVAR P5 V3
# record to TP-101 the hysteresis for temperature below the lower limit
1 PARAMWRVAR P5 V2

!REACTS
* C3 REPEAT A0
* C7 REPEAT A1
# program is completed
```

Appendix D
(recommended)

Updating of firmware

1 GENERAL INFORMATION

To upgrade the integrated software, EM-486 uses files «EM486FW1.FUS», «EM486FW2.FUS» or «EM486FW3.FUS» from folder «UPGRADES» located on SD memory card, formatted in the FAT or format FAT32.

Updating by these files may be held in a special update mode of firmware.

2 TRANSMITTING THE EM-486 UPDATING FILES

To transfer the update files it is possible in two ways:

1) record files to SD card on a personal computer or other external device and put the card into the EM-486, then enter the update mode of the firmware, as shown in table D.1;

2) if updating via WEB interface is permitted in the parameter settings, tab "Other" (see para.5.3.3), go to the tab "Files", select the firmware file and click the button "Upload file". The file will be written to the folder "UPGRADES" with the name "EM486FW2.FUS". Then click "Program". The firmware update will be done automatically for 3-4 minutes.

3 UPDATE MODE OF FIRMWARE

The device can be set in mode of firmware updating after power supply and restart. The setting in that mode is made automatically (at updating via WEB-interface or at update failure) or manually (at the button «R» being pressed during a startup). The procedure of entering in mode of updating is resulted in Table D.1.

Table D.1 – Entering the mode of firmware updating

No	Step	Button «R»	Display	Time	Remark
1	Initialization	Pressed		0,5 sec	To cancel the updating, release the button «R» at these steps
2	Stand-by	Pressed		1 sec	
3	Notification about entering in mode of updating	Pressed	Entering upgrade mode	5 sec	
4	Offer to enter the mode of updating	Pressed	To enter upgrade mode – release button	2 sec	To enter the mode of software updating, <u>release the button «R»</u> at this step
5	Protection against incidental pressing	Pressed	–	–	Holding the button pressed will cancel the firmware updating

After manual entering in mode of updating, select the file of updating. The procedure for file selection is resulted in table C.2. To cancel the updating, cut off the power supply of EM-486 or wait until automatic completion of updating mode.

Table D.2 – Selection of updating file

No	Step	Button «R»	Display	Time	Remark
1	Finding the available files		Searching for upgrade files...	(depends on the found files)	
3	Notification about entering in mode of updating	released	Name and version of updating file	5 sec	To select a file, <u>press and release the button «R»</u> at this step
4	Offering all files of updating	released	–	(depends on the found files)	Repeat the step 3 for each file
6	Repeated offer	released	–	(depends on time of step 4)	Repeat the steps 3–4 for 3 times
7	Protection against incidental entering in the mode of updating	released	–	–	The file cancelation cause the escape from the mode of firmware updating

At automatic entering into the mode of firmware updating or at manual selection of file, the updating is made from the file. The procedure of updating is described in table C.3.

Table D.3 – Updating of firmware

№	Step	Button «R»	Display	Time	Remark
1	Start of updating	–	Upgrading firmware	2–10 sec	
2	Updating the firmware	–	(performance line shows the process of updating)	(depends on the file of updating)	Time until the end of process of updating is shown on the display
3	Updating is successfully completed	–	Firmware upgrade success	5 sec	
4	Startup of firmware	–	–	–	

The errors detected during the updating process are shown on the display. The possible errors during the updating of firmware are listed in table C.4.

NOTE! IF THERE ARE CRITICAL ERRORS DURING THE UPDATING MODE THE OPERATION OF THE DEVICE IS NOT POSSIBLE.

In this case the indication of a critical error is made during an hour, after that the device automatically restarts. If an error is as a result of incidental event, the firmware will be restored from the file on the memory card.

Table D.4 – Codes of warning in software updating mode

Code	Warning	Actions	Remarks
2	Firmware can not be started	Initialization of mode of emergency updating: Auto start of updating from the selected file or from the first available file (if any)	The warning is shown at selection of firmware updating in WEB-interface or as a result of other error and is automatically corrected with the help of available files of software updating
3	Error while current process of firmware updating	Similar to №2, but the file with an error has less priority	The error is automatically corrected with available files of updating
4	The files of updating are not available	Escape from the mode of updating, start of available firmware	The device can continue operation but for reprogramming the file of updating should be loaded in the folder «UPGRADES» on the device SD memory card
5	Emergency mode – firmware can not be started	Waiting for manual restart of device or restart automatically in 1 hour	The error is a result of three-time entering in emergency mode as a result of other errors. The correct file of firmware updating should be loaded in the folder «UPGRADES» on the SD memory card. If the error is repeated, contact the manufacturer
6	Emergency mode – error during the current firmware updating	Waiting for manual restart of device or restart automatically in 1 hour	The error is a result of three-time entering in emergency mode as a result of other errors. The correct file of firmware updating should be loaded in the folder «UPGRADES» on the SD memory card. If the error is repeated, contact the manufacturer
7	Unrecoverable error – no available files of updating, the firmware can not be started	Waiting for manual restart of device or restart automatically in 1 hour	The error is a result of three-time entering in emergency mode as a result of other errors. The correct file of firmware updating should be loaded in the folder «UPGRADES» on the SD memory card. If the error is repeated, contact the manufacturer