

REV	DESCRIPTION	DATE

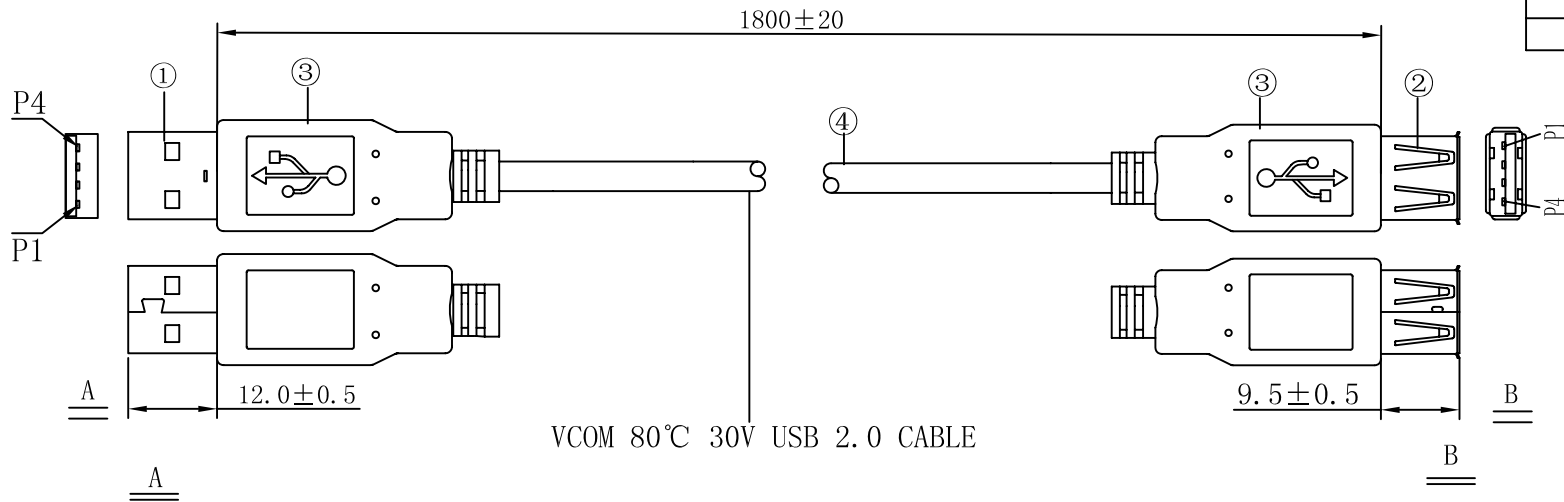

WIRING TABLE:

<u>A</u>		<u>B</u>
1	---Red---	1
2	⊗ White---	2
3	⊙ Green---	3
4	---Black---	4
G	---DW+BD---	G

⊗ ⊙ Twist pair

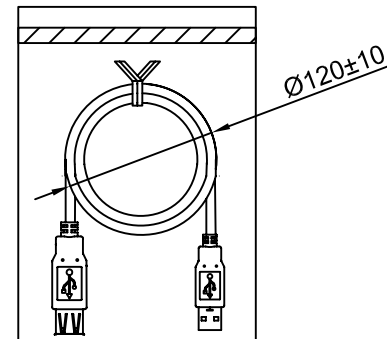

Test Conditions:

1. 100% open & short circuit test;
2. Insulation Resistance: 2.0ohm (MAX);
3. Conduction Resistance: 5Mohm (MIN) at 300V DC/0.01S .

VCOM VCOM INTERNATIONAL LTD.

④	CABLE:USB2.0[1P+2C+AL FOIL+DW+BD] OD:4.5±0.2mm, PVC JACKET, BLACK		mm	1800	
③	OVER MOLDING:PVC-50P BLACK PVC		g		
②	PLUG:USB A FEMALE SOLDERING TYPE, NICKEL-PLATED, PBT WHITE COLOR	PCS		1	
①	PLUG:USB A MALE SOLDERING TYPE, NICKEL-PLATED PBT WHITE COLOR	SET		1	
NO.	MATERIAL DESCRIPTION	MATERIAL NUMBER	UNIT	QTY	

ITEM	USBAM-USBAF	CUSTOMER		UNIT	mm	PAGE:1of1
PART NO.	VC-F02-0014	CUSTOMER NO.				⊗ ⊙
PRODUCT NO.		REV		A/0	DATE	2014-03-07
DRAWN BY:xiang		CHECKED BY:		APPROVED BY:		