

TLC.

Hook clamps

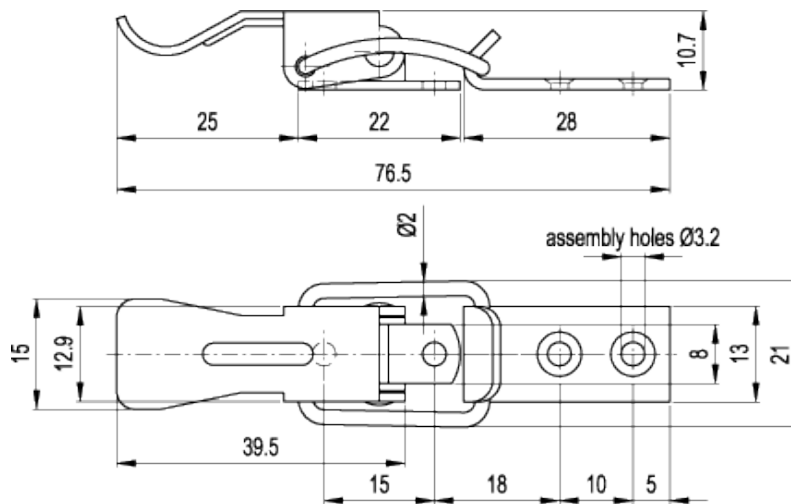

INOX
Stainless Steel



technical informations

Lever body

TLC.Z: zinc-plated steel.

TLC.S: AISI 304 stainless steel.

Catch bracket

TLC.Z: zinc-plated steel.

TLC.S: AISI 304 stainless steel.

Special executions on request (For sufficient quantities)

- Hook clamps in unplated steel, nickel-plated steel or bronzed steel.
- Catch brackets in different shapes and finishes.

Features and applications

AISI 304 stainless steel, thanks to its high resistance to corrosion, allows the application of the TLC.S hook clamps on machines and equipment in those sectors where laws or particular hygienic, climatic and environmental factors make it

mandatory to use corrosion resistant materials.

Radial strength tests

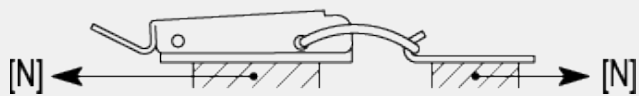

Standard Elements		Maximum working load	Load at breakage	Weight
Code	Description	[N]	[N]	g
420071	TLC.Z-15/76.5+R	400	1000	16
420072	TLC.SST-15/76.5+R	400	1500	16



ELESA and GANTER models all rights reserved in accordance with the law. Always mention the source when reproducing our drawings.

STANDARD MACHINE ELEMENTS WORLDWIDE