

嘉尼企業股份有限公司 CANAL ELECTRONIC CO., LTD.

TOGGLE SWITCH MODEL: TA SERIES

RATING:(1) 6A 125VAC (UL/CSA)
 (2) 3A 250VAC (UL/CSA)
 (3) 3A 125VAC "L" (UL/CSA)
 DIELECTRIC WITHSTAND VOLTAGE: 1000VAC 1 MIN
 INSULATION RESISTANCE:100MΩ(MIN)
 CONTACT RESISTANCE:20mΩ(MAX.)

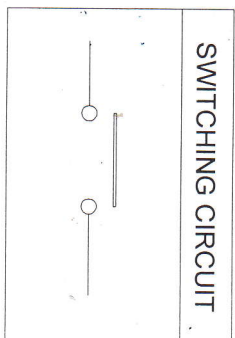
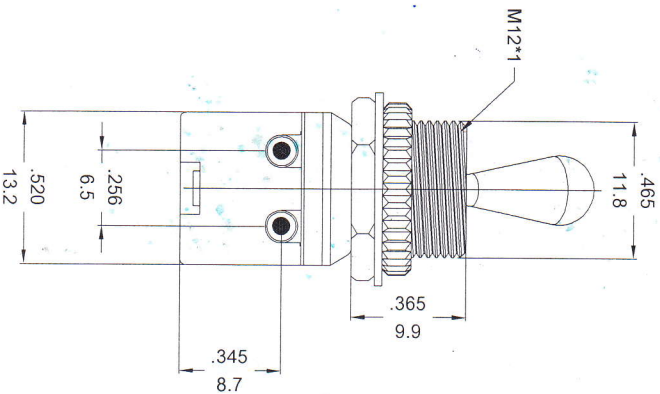
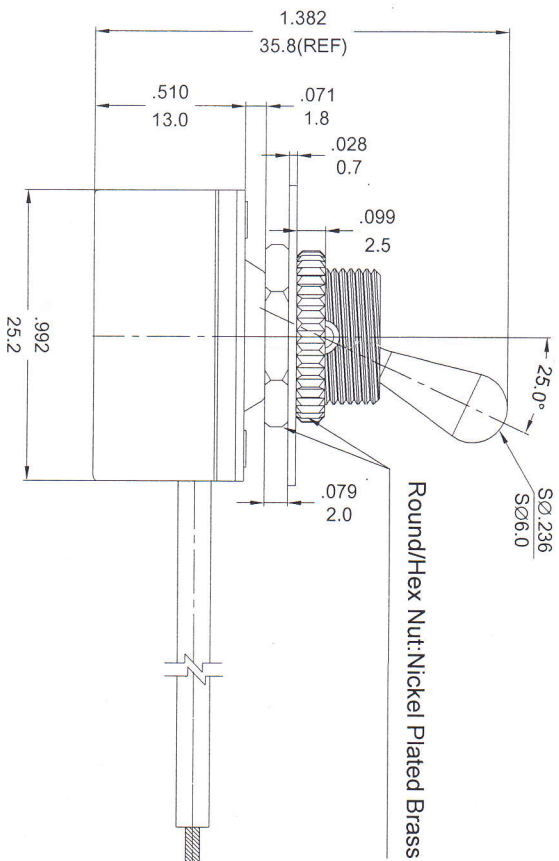
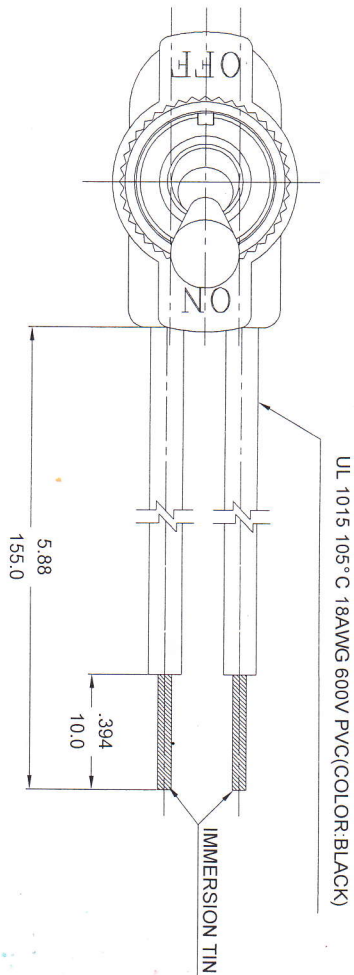

NOTES: TOLERANCES UNLESS OTHERWISE SPECIFIED: ± 0.12 (in/mm)

REVISION	DESCRIPTION	REVISED BY	TOLERANCES		ANGLE $\frac{1}{2}^{\circ}$	SCALE	UNIT	PART NAME	TA SPEC DRAWING	DWG NO
			DRAWN BY	CHECKED BY						
4			張勤蘭		馮紅崗	3/2	mm			S4011A
3										
2										
1										
2011.02.09		首次出圖	張勤蘭		張勤蘭				TA-02A-A	