

# Circular connectors for small electronic devices

## SR30 Series



### ■ Features

#### 1. Compact and light weight design

Optimally suited for use in small electronic devices such as radio equipment, the SR30 has a maximum outer shell diameter of  $\phi 15$ .

#### 2. Robustness

The metal construction provides for a small but robust connector.

#### 3. Smart design

The flexible strain relief is strong enough to maintain its shape and resist bending stresses.

#### 4. Variation

Items	
No. of Contacts	4 contacts, 6 contacts, 7 contacts
Connector type	Plug and jack : Straight Receptacle : Straight
Termination version	Plug and jack : Soldering Receptacle : Soldering
Receptacle mounting method	Tightened with nuts on either of the front or back of the panel (6-contact only)

### ■ Product Specifications

Ratings	Rated current	1A	Operation temperature range	-10 to +60°C
	Rated voltage	100V AC, 140V DC	Storage temperature range	-10 to +60°C

Items	Specifications	Conditions
1. Contact resistance	10m $\Omega$ max	Measured at 1A DC
2. Insulation resistance	200M $\Omega$ min	Measured at 100V DC
3. Withstanding voltage	No flashover or dielectric breakdown.	300V AC for 1 minute
4. Vibration resistance	No electrical discontinuity for 10 $\mu$ s or greater.	10 to 55Hz/cycle, amplitude : 0.75mm, 3 axis directions, 2 hours each
5. Shock resistance	No electrical discontinuity for 10 $\mu$ s or greater.	Acceleration : 490m/s <sup>2</sup> , duration : 11ms, 3 axis directions, 3 cycles each
6. Mating cycle	Contact resistance : 15m $\Omega$ max	1,000 times
7. Temperature cycle	Insulation resistance : 200M $\Omega$ min	-30°C : 30 minutes → Normal temperature : 10 to 15 minutes → 85°C : 30 minutes → Normal Temperature : 10 to 15 minutes, left for 5 cycles
8. Humidity resistance	Insulation resistance : 10M $\Omega$ min (at high humidities) 100M $\Omega$ min (when dry)	Temperature : 40°C, relative humidity : 90 to 95%, left for 96 hours

### ■ Materials / Finish

Items	Material	Finish	Remarks
Plug Jack	Insulator	Polyacetal resin	—
	Contact	Brass or phosphor bronze	Gold plating
	Shell	Brass or zinc die-cast	Nickel or Chromium plating
	Hood	Chloroprene rubber	—
	Clamp	Brass	—
	Screw	Steel	Nickel plating
Receptacle	Insulator	Polyacetal resin	—
	Contact	Phosphor bronze	Gold plating
	Shell	Brass	Chromium plating
	Gasket	Polyamide resin	—
	Nut	Steel	Nickel plating

## ■ Product Number Structure

Refer to the chart below when determining the product specifications from the product number.  
Please select from the product numbers listed in this catalog when placing orders.

### ● Connector

#### SR30 - 10 W P A - 6 P (\*\*)

①      ②      ③      ④      ⑤      ⑥      ⑦      ⑧

① Model name : SR30 Series
② Shell size : Shell size is the outer diameter of the mating end of the plug.
③ Particularity : No indication : Standard W : Waterproof
④ Shell type P : Plug R : Receptacle J : Jack
⑤ Shell variation : Connectors are distinguished by A, B, or C if another variation is applied in the same form.
⑥ Number of contacts : Indicates the number of contacts.
⑦ Contact form P : Male contact S : Female contact
⑧ Other specifications : 2 numerical digits will be added when there is a specification change other than shown in positions ①~⑦

### ● Accessory

#### SR30 - 10 RC 1 (\*\*)

①      ②      ③      ④      ⑤

① Model name : SR30 Series
② Shell size : Shell size is the outer diameter of the mating end of the plug.
③ Accessory name : RC : Receptacle cap
④ Form type : A number is added if there are some variations.
⑤ Other specifications : 2 numerical digits will be added when there is a specification change other than shown in positions ①~④

■ Plug

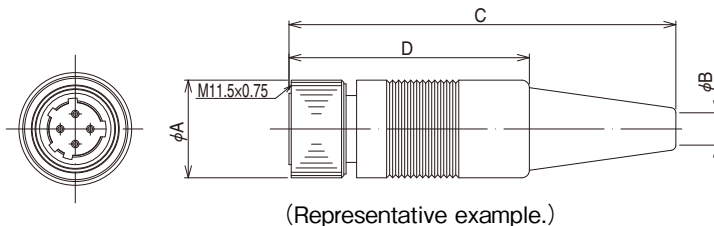

Part No.	HRS No.	No. of contacts	φA	φB	C	D	Remarks
SR30-10PE-4P(71)	103-0265-2 71	4	13	4.3	51.5	32	—
SR30-10PE-6P(74)	103-0258-7 74	6		5.2	49.0	31	See Note 1
SR30-10PG-6P(31)	103-0273-0 31			5.7		—	See Note 1
SR30-10PF-6P(71)	103-0319-0 71	7	15	5.5	55.0	—	Silver plated contacts only
SR30-10PF-7P(71)	103-0316-1 71			—	—	—	
SR30-10PM-4P(31)	103-0341-9 31	4	6	5.7	49.0	—	—
SR30-10PM-6P(31)	103-0288-8 31	6		4.3	57.5	38	—
SR30-10PQ-6P(71)	103-0313-3 71						Screw attached
SR30-P	103-0266-5	Metal fitting for clamping				—	—

Note 1 : When ordering the SR30-10PE-6P or SR30-10PX-6P, order SR30-P cable clamps separately, because such plugs have no cable clamps.

Note 2 : The inner diameter of solder pot for male contact is φ0.8.

Note 3 : Cable clamping force, cable rotation force, and other aspects may differ depending on the cable construction. We recommend that you verify the suitability of the cable assembly before use or production.

■ Receptacle (Jam nut to be fastened)

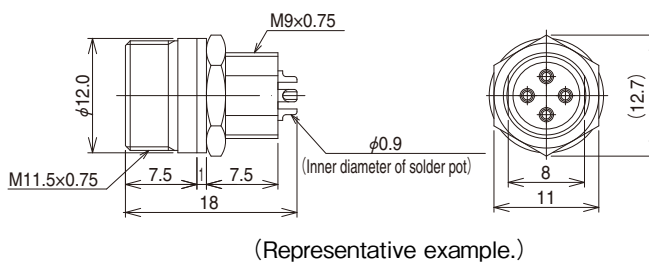

Part No.	HRS No.	No. of contacts	Remarks
SR30-10R-4S(71)	103-0264-0 71	4	—
SR30-10R-6S(71)	103-0239-2 71	6	—
SR30-10R-7S(71)	103-0317-4 71	7	Silver plated contacts

(Remarks) The mounting panel thickness should be 5mm or less.

Dec.1.2022 Copyright 2022 HIROSE ELECTRIC CO., LTD. All Rights Reserved.

## ■ Receptacle (Jam nut to be fastened from front panel)



SR30-10RD-6S(71)

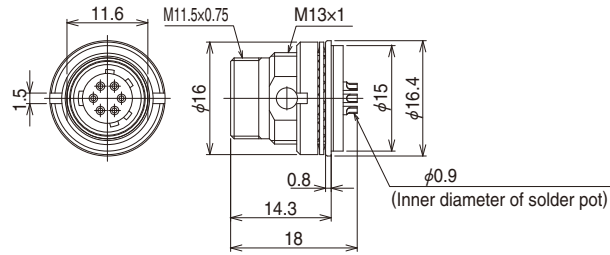

(Representative example.)

Part No.	HRS No.	No. of contacts
SR30-10RD-6S(71)	103-0302-7 71	6

(Remarks) The mounting panel thickness should be 3 mm or less.

## ■ Jack



SR30-10JE-6S(72)

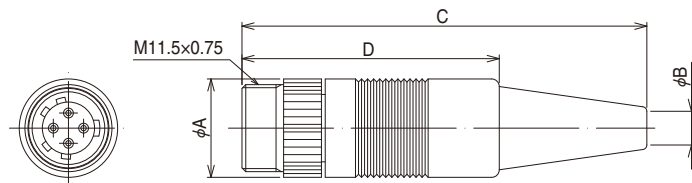

(Representative example.)

Part No.	HRS No.	No. of contacts	φA	φB	C	D	Remarks
SR30-10JE-4S(71)	103-0301-4 71	4	13	4.3	53.5	34	—
SR30-10JE-6S(72)	103-0259-0 72	6					
SR30-10JF-7S(71)	103-0330-2 71	7		5.5	57	—	Silver plated contacts

Note 1 : When ordering the SR30-10JE-6S receptacles, order SR30-P (103-0266-5) cable clamps separately, because they have no cable clamps.

Note 2 : The inner diameter of solder pot for male contact is φ0.9.

Note 3 : Cable clamping force, cable rotation force, and other aspects may differ depending on the cable construction. We recommend that you verify the suitability of the cable assembly before use or production.

## ■ Cap



SR30-10RC1(71)

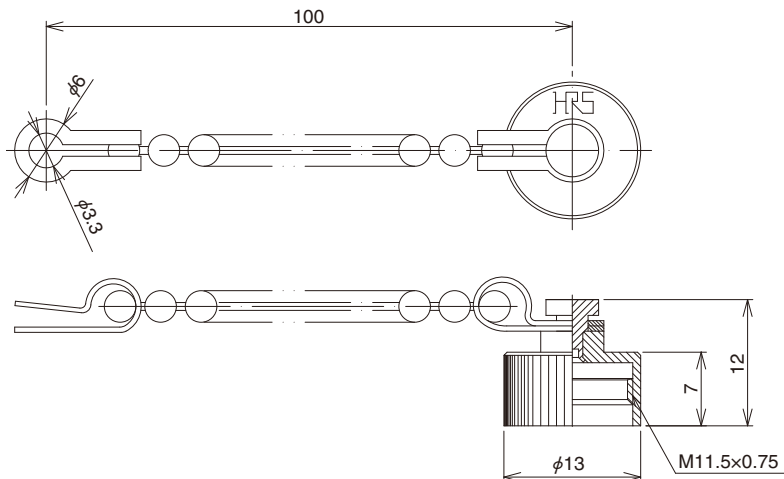

Part No.	HRS No.	Remarks
SR30-10RC1(71)	103-0344-7 71	—

## ◆ Reference termination procedure (plug and jack sides)

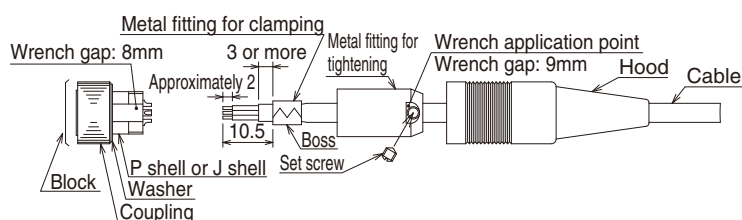

For details on usage, please contact our Engineering Dept. or Sales Dept.



### Jig for termination

### Crimping Tool

(for use with cable diameters between  $\phi$  4.2mm and 4.8mm)



(handle shape is shown as an example.)

### ○ Assembly procedure

1. Please use the cables with a finished outer diameter of between  $\phi$ 4.2 and 4.8 and the nominal conductor cross section of 0.3mm<sup>2</sup>.
2. Pass the cable through the hood and metal fitting for tightening in order. Cut the cable end at an approximate length as shown in the figure on the left.
3. Insert the block into the jig for termination and terminate the cable by soldering.
4. Crimp the cable onto the metal fitting for clamping (SR30-P) several times with using the crimping tool (SR30-10PE-T), in such a way that the outer diameter becomes approximately  $\phi$ 5.2.
5. After termination, tighten the metal fitting for tightening into the threaded section on the block (P shell, J shell) to a torque of approximately 2 N·m (20 kg·cm), using a single-acting torque wrench. When performing tightening on the jack side, be sure to fix the wrench application point on the J shell.
6. Secure the metal fitting for clamping by tightening a set screw on either side of the two bosses on the metal fitting for clamping to a torque of approximately 0.1 N·m (1 kg·cm) in such a way that the tip of the set screw slightly sinks.
7. Place the hood over the metal fitting for tightening. The procedure has been completed. Please be sure to apply a small amount of thread adhesive to prevent loosening.

## ◆ Precautions

1. Switch off the power of the circuit before disconnecting or plugging-in the connectors.
2. Use connectors with socket contacts at the power side of the circuit.
3. Be sure to use the connector with the screw lock mechanism fully tightened.
4. This product uses silver plated contacts. Please be aware that silver easily reacts to sulfur gases, causing discoloration or degradation when exposed to certain environmental conditions as shown below. These conditions include areas with:
  - Dusty site
  - Area or location with a high density of sulfur dioxide gas, hydrogen sulfide gas, nitrogen dioxide gas, or other gas (Emission gases from vehicles and factories, etc.)
  - Highly fluctuating temperatures, such as close to a heating apparatus.

In addition, it is recommended to store the products in their original packaging or similar state in order to prevent discoloration.

- Temperature : -10 to +60°C, relative humidity : 85% or lower (An environment where temperature and relative humidity are constant and there is little temperature variation.)

Please use the products within six months after delivery. (If the storage period has expired, please examine the connectors and solder cups for corrosion and/or tarnish.)

