

UNI_USB.pdf

9 Pages

Last Revised 18/03/13

Universal RFID Socket board with USB interface

The Universal RFID Socket board is the baseboard for the MicroRWD RFID reader modules from IB Technology.

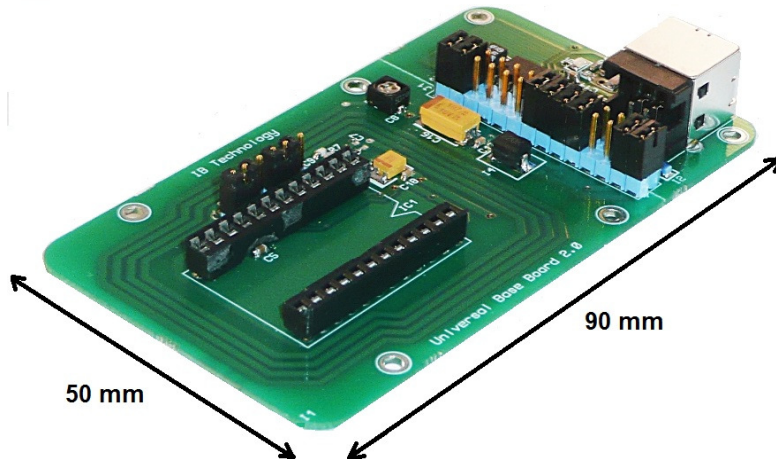

MicroRWD modules are low-cost, pin compatible and host command compatible Proximity reader modules for low-frequency (125kHz) Hitag 1, Hitag S256/2048, Hitag 2, EM4102 and high-frequency (13.56MHz) Mifare 1k/4k/Ultralight, ICODE SLI RFID tags and contactless smart cards. The module solutions only require a 5v supply and an antenna coil to be fully featured read/write systems with optimised easy to use host commands. All modules use the same universal 24 pin DIP package so customers can migrate between different transponder technologies with the minimum of design change.

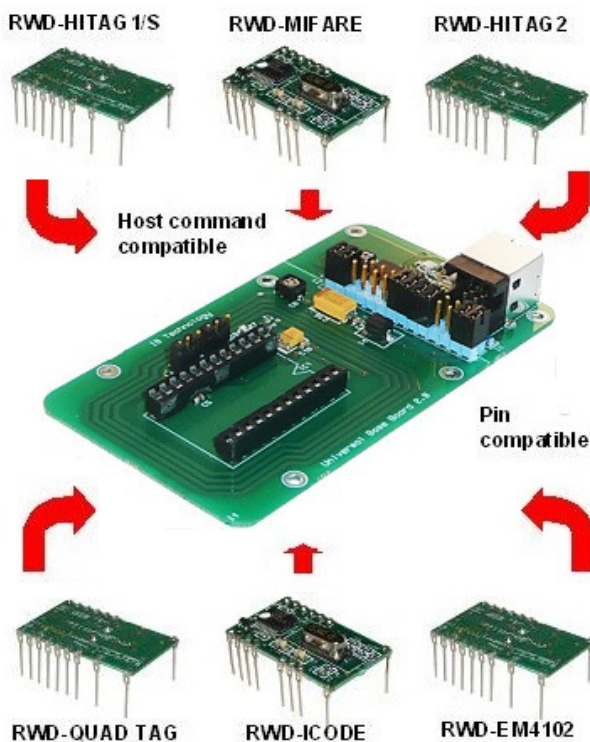

The Universal Socket board provides the antenna, and the serial-to-USB interface to the MicroRWD module. Specifically the board has a 24-pin DIP socket for the appropriate MicroRWD module to be plugged into, LEDs for visual status indication and selectable PCB and coil based antenna for 13.56MHz or 125kHz operation.

The 14-way x 2-row header provides jumper links for all available power and I/O signals.

The Universal Socket board can be connected to the USB port of a PC with the FTDI VCP (Virtual Comm Port) driver installed, allowing the Windows applications to communicate with the Reader module via the allocated COM port.

ib technology

Universal socket board (with 125kHz coil antenna mounted on the underside)

The Gerber PCB layout files for this board are available free-of-charge on request.

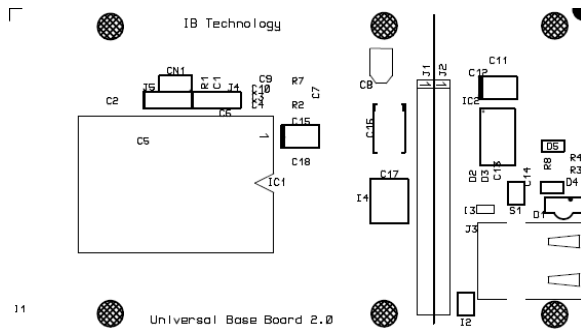
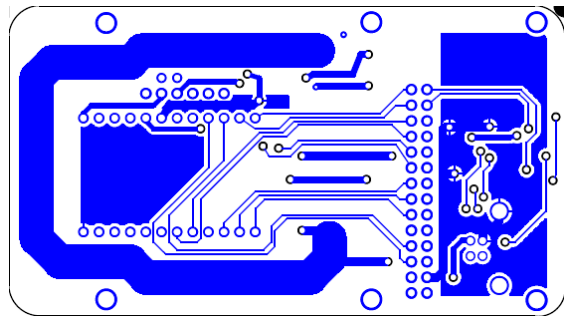
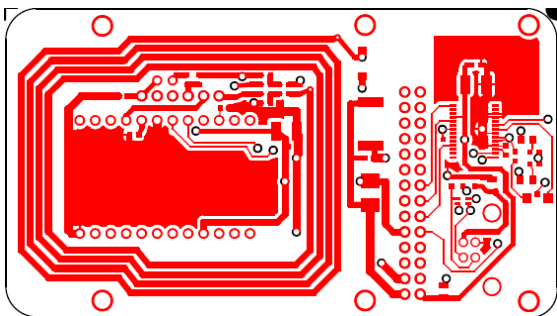
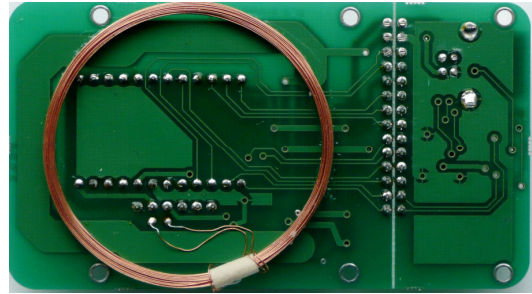
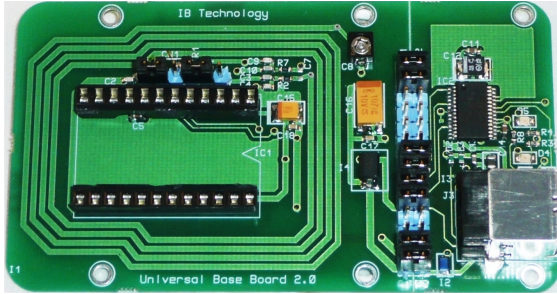

The Universal Socket board has the same basic footprint and mounting holes as the OEM-MICODE boards and has been designed to fit in the IBT plastic case.

The custom plastic case (95 x 60 x 25mm) is available in high-gloss WHITE or high-gloss BLACK. It has integral LED light pipes and is ideal for “desktop” applications.

ib technology

The Universal Socket board has link options to select the on-board 13.56MHz PCB antenna or the external 125kHz antenna coil (mounted on the back of the PCB) and to connect all the available power and I/O signals.

The Board is also scored along the centre line of the 14-way, 2-row header pins so that the PCB can be broken in half to separate the RFID circuit from the USB interface circuit. This allows the RFID section to be used as an embedded board for directly connecting the power and TTL communication signals to the application circuit for in-circuit evaluation.

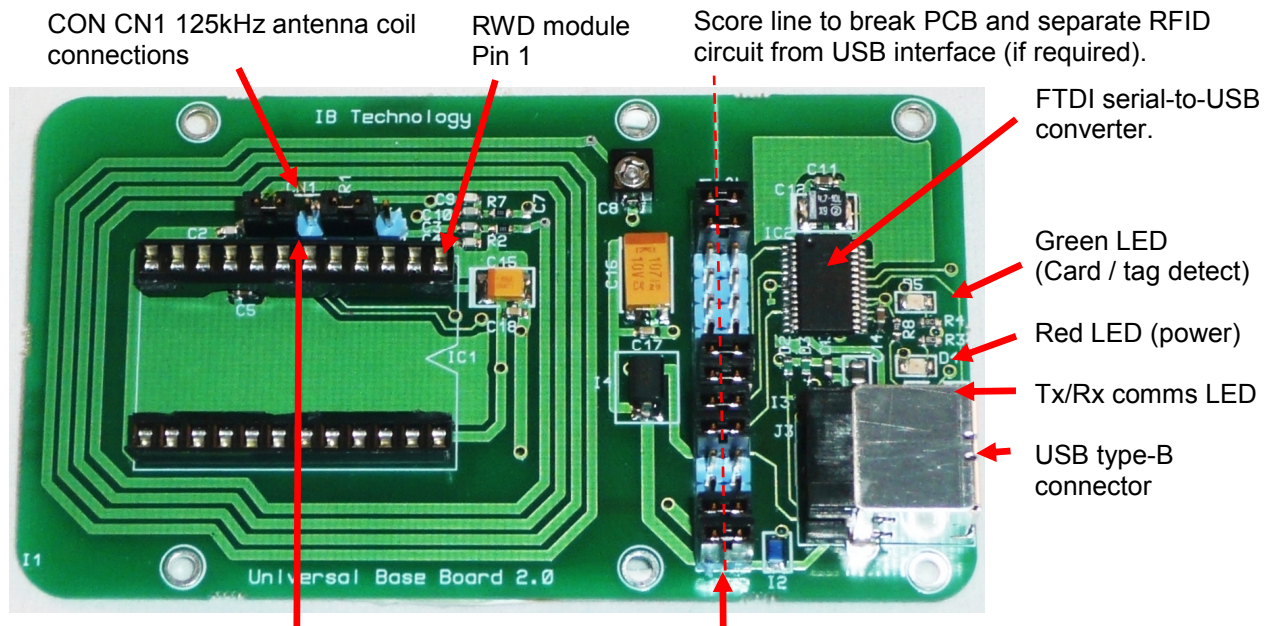

J5 and J4 links for antenna selection.

J1 / J2, 14-way x 2-row links for Power and I/O signals

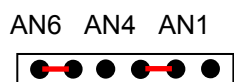

AN2 AN5 AN3

125kHz antenna coil

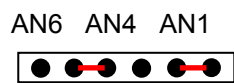

AN2 AN5 AN3

13.56MHz PCB antenna

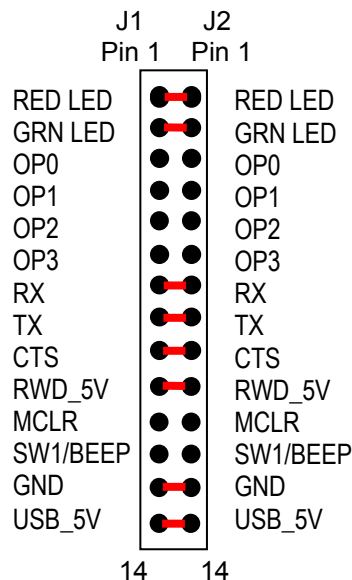

Red links indicate default connections for power and communication.

Operation of MicroRWD module

The Universal Socket Board with the MicroRWD module fitted can be powered directly from an external 5-volt power supply and connected to a host microcontroller using TTL serial communication by connecting directly to the J1/J2 14-way, 2-row header pins. TTL serial communication (at 9600 baud, 8-bits, 1-stop, no-parity) uses Tx, Rx signals and CTS for “hardware handshaking”. This allows simple connection to an embedded system for evaluation and prototyping.

Alternatively, the Universal Socket board with the J1/J2 links set correctly can be connected to a PC using the USB interface (type-B connector), power is then provided directly by the USB bus.

The Universal Socket Board uses the FTDI (Future Technology Devices International Ltd) FT232RL serial-to-USB converter chip. FTDI provide VCP (Virtual COM Port) USB drivers for most common Operating Systems including Windows, MAC and Linux.

The appropriate VCP USB driver should be downloaded and installed from: <http://www.ftdichip.com/Drivers/VCP.htm>.

On a Windows based system this provides the Virtual Communication Port on the PC so that Programs can communicate over the USB interface using the allocated serial port. The Windows DEVICE MANAGER program can be used to display the allocated COM port number.

IB Technology provide Windows applications and Debug utilities that allow all the features of the MicroRWD module and the card/tag type to be easily evaluated.

For example:

For Evaluation of RWD-MICODE, download and install the (Win32) RWD-MIFARE / ICODE Windows application:

(http://www.ibtechnology.co.uk/Win32/Win32_Mifare_Icode.ZIP).

OR

for Windows 7, 64-bit Operating Systems, use the new .NET (Win64) RWD-MIFARE-ICODE Windows version (http://www.ibtechnology.co.uk/Win32/MicroRWD_MFIC-REL-1_0.zip).

For evaluation of RWD-QT, download and install the (Win32) RWD-QT Windows application (http://www.ibtechnology.co.uk/Win32/Win32_QT.ZIP).

OR

for Windows 7, 64-bit Operating Systems, use the new .NET (Win64) RWD-QT Windows version (http://www.ibtechnology.co.uk/Win32/MicroRWD_QuadTag-REL-1_0.zip).

Download the .ZIP compressed file, un-zip and run SETUP.exe to install in usual manner. Further information on the Windows programs and how to install and set-up the RS232 HEX TERMINAL PROGRAM can be found on pages 5 and 6 of OPERATION.PDF (<http://www.ibtechnology.co.uk/pdf/Operation.PDF>)

Double click on the MicroRWD program icon and once the application is running, select the COM PORT option and select the COM PORT being used. Windows DEVICE MANAGER can be used to locate the correct COM port number allocated by the USB VCP (Virtual Comm Port) driver.

When the Universal Socket Board with MicroRWD module fitted is powered-up, the Green LED turns ON (and Red LED turns OFF) when the appropriate card or tag is in range. This is a proximity Reader system so typical operating range is up to 5cm (using 13.56MHz RWD-MICODE) and 8cm (using 125kHz RWD-QT).

For further information on the MicroRWD Reader modules, Windows applications and datasheets, please also see:

<http://www.ibtechnology.co.uk/ibthardwareanswers.htm#evaluation>

For further information on the MicroRWD communication protocol and examples of sending commands and the responses from the Reader, please also see:

<http://www.ibtechnology.co.uk/ibthardwareanswers.htm#communicationprotocol>

Universal Socket Board BOM (Bill-of-Materials)

The Universal Socket Board has been designed with thorough attention to noise suppression and filtering of the 5-volt supply (see circuit schematics below). In simple applications many of these precautions can be omitted. The Bill-of-Materials list below shows the typical parts-list with Distributor part-numbers, in most cases equivalent components can be used accordingly.

Location	Description	Package	Farnell Part No.		QTY
C1,C2	47pF 100V +-5% NPO 0603	0603R	1759128		2
C3,C10	0603, NPO, 50V, 22PF, ± 5%	0603R	8819831		2
C4	180pF 100V +-5% NPO 0603	0603R	1813436		1
C5,C6,C11,C14	Murata 0603 50V X7R 0.1uF 10%	0603R	8820023		4
C8	Murata Ceramic 7/50pF 50V dc SMD Trimmer	TRIM-CAP-CTZ3		RS721-5329	1
C9	220pF 100V +-5% NPO 0603	0603R	1813437		1
C12	SM TANT 4.7UF, 16V, 10% CASE B	CHPCTANT ETC-B	9753893		1
C13	10nF 50V +-10% X7R 0603	0603R	1759102		1
C15	Tant 10uF 16V 10% CASE B	CHPCTANT ETC-B	9753893		1
C16	B45197A2107K409 - CAPACITOR, CASE D, 100UF, 10V	CHPCTANT ETC-D	9751050		1
C17,C18	47nF 25V ±10% X7R 0603	0603R	8820007		2
D1	KPBA-3010ESGC-F01 LED	SMT-BCL	8530165		1
D2,D3	WE-VE FemtoF Suppressor 0.05pF 6Vdc 0603	0603R		Wurth 8231606	2
D4	MULTICOMP - OVS-0808 - LED 0805 SUPER BRT RED	0805LED	1716768		1
D5	MULTICOMP - OVS-0804 - LED 0805 SUPER BRT TRUE GRN	0805LED	1716766		1
I2	WUERTH INDUCTOR, 0805, 10NH, 600MA	805	1748800	Wurth 8231606	1
I3	Wurth Noise Suppressor 90OHM, 370MA SMD	744-231-091	1636469	Wurth 744231091	1
I4	CM453232-220KL 22UH, 180mA, 10% 4532	4532	9358080		1
IC1	IBT Micro RWD module	18mm wide DIP		IB Technology	1
IC2	FTDI USB to UART SSOP28	SSOP28	1146032		1
J1,J2	Sil Header 14 way,14W Header	14W-SIL-STRIP	5217805		2
J3	USB TYPE B, THT, CONNECTOR, 4P	USB	1076665		1
J4,J5	Sil Header3 way,3W Header	LINK3	5217805		1
R1	0603 1% 10R 0.1W	0603R	1469751		1
R2,R7	0603 0R 0.1W	0603R	1469739		2
R3,R4	0603 1% 1K 0.1W	0603R	1469740		2
R8	0603 1% 300R 0.1W	0603R	2073463		1
S1	WE-VS Varistor 4Vrms 5.5VDC 80A 0805	805	1636439	Wurth 82550040	1
J4,J5	JUMPER SOCKET, BLACK, 2 WAYS		150410		2

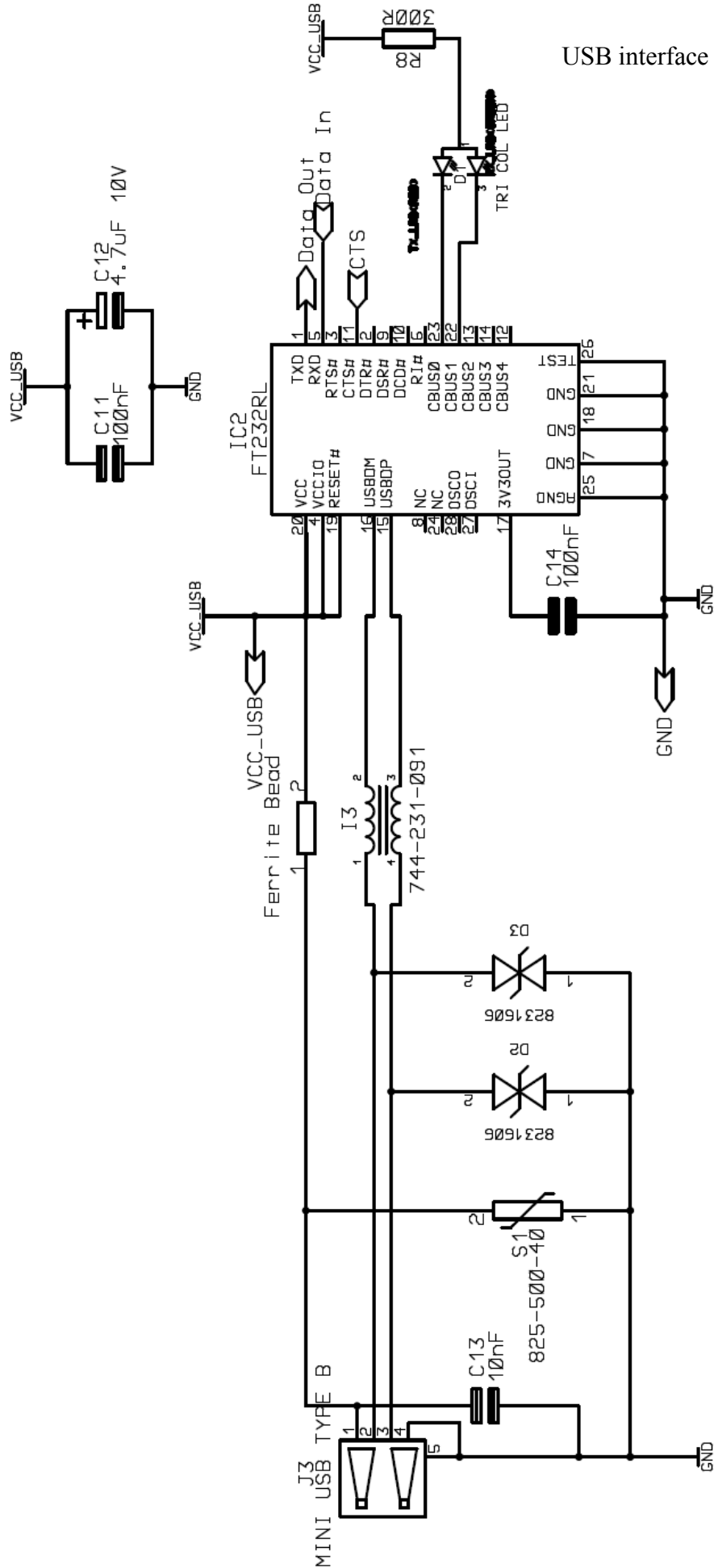

Micro RWD interface and headers schematic - sheet 2

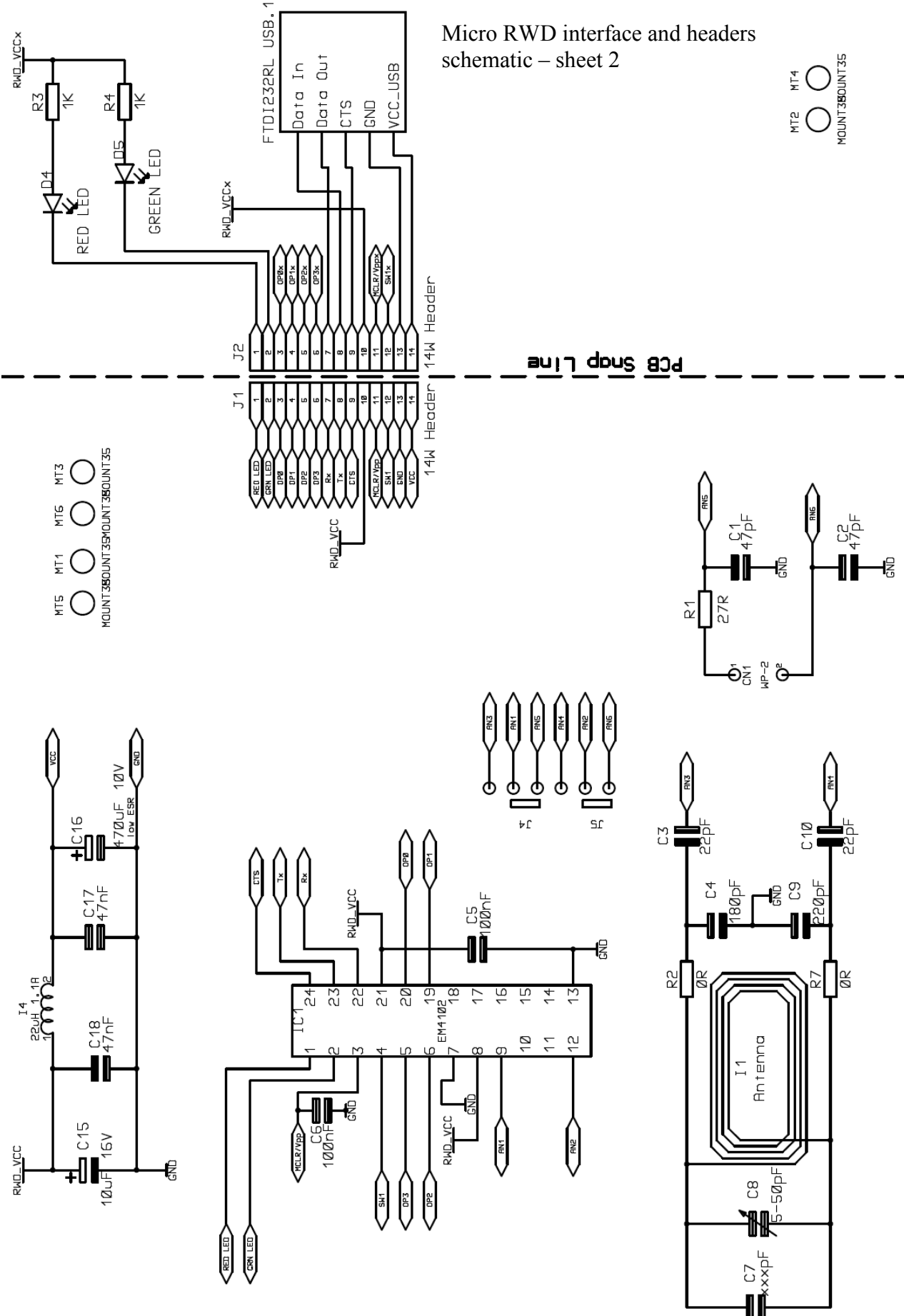

MicroRWD pin out

Pin Name	DIP No.	I/O Type	Buffer Type	Description
LED1	1	O	TTL	Red LED connection. 25ma max sink current
LED2	2	O	TTL	Green LED connection. 25ma max sink current
RESET/MCLR	3	I	ST	Reset pin internally pulled high. Active low. Normally not connected
SW1/BEEP	4	I/O	TTL	Switch input to override output drives or BEEP output on some versions.
OP3	5	O	TTL	Aux output drive. 25ma max sink current.
OP2	6	O	TTL	Aux output drive. 25ma max sink current.
GND	7	P	-	Ground reference for logic and analogue pins
VCC	8	P	-	+5v Positive supply
AN1	9	P	AN	Antenna connection. Up to 200mA peak current, 100v peak voltage. 125kHz or 13.56Mhz drive into 700 uH or 1 uH antenna.
-	10	-	-	Not connected
-	11	-	-	Not connected
AN2	12	P	AN	Antenna connection.
GND	13	P	-	Ground reference for logic and analogue pins. Normally used for antenna screen connection
-	14	-	-	Not connected
-	15	-	-	Not connected
-	16	-	-	Not connected
-	17	-	-	Not connected
-	18	-	-	Not connected
OP1	19	O	TTL	Aux output drive. 25ma max sink current.
OP0	20	O	TTL	Aux output drive. 25ma max sink current.
VCC	21	P	-	+5v Positive supply
RX	22	I	TTL	Serial communication Receive line. 9600 baud, 8-bit, 1-stop, no parity
TX	23	O	TTL	Serial communication Transmit line
CTS	24	O	TTL	Serial communication CTS handshake. RX enabled when CTS goes low and disabled when high.

(I/O = Input/Output, AN = Antenna output, P = Power, ST = Schmitt Trigger input, TTL = TTL logic I/O)

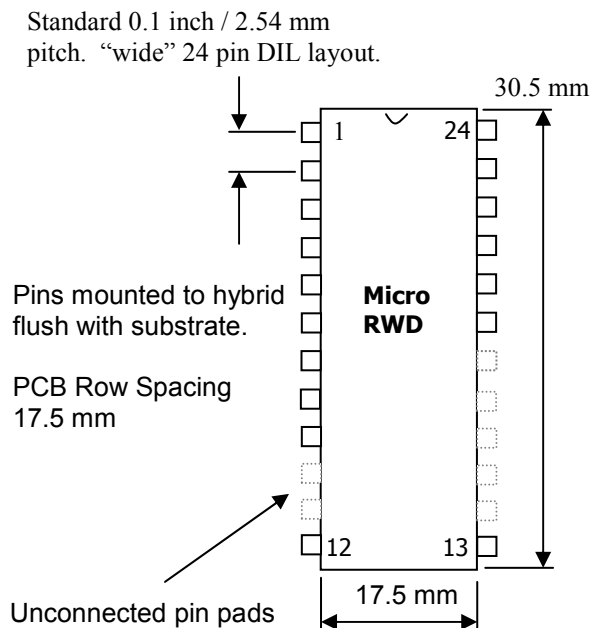

Universal RFID socket board specifications

Basic preliminary electrical specifications.

Parameter	Typical Value
Supply Voltage	5v DC regulated on J1/J2 or 5v via USB bus
Operating temperature	-25 deg C to + 70 deg C
Average current consumption: MicroRWD + LEDs ONLY (default 100ms RF-OFF polling delay)	Approx 20mA
Average current consumption: MicroRWD + LEDs + USB interface.	Approx 25mA
Maximum board current (MicroRWD + all interfaces active)	Approx 50mA
Peak antenna voltage (optimum antenna tuning)	Up to +/- 100v (200v peak-to-peak)
Peak antenna current (optimum tuning)	Up to 200ma
Communication time for Tag authentication	20ms (Hitag)
Communication time for 32 bit WRITE operation	30ms (Hitag)
Maximum data rate (between Tag and RWD)	4k baud or 53 / 106k baud
Range (dependent on antenna dimensions and tuning)	Up to 15cm (125kHz) or 8cm (13.56MHz)
Auxiliary output drive current	Up to 25ma sink
Switch input (pulled up)	Active low
Serial Interface	TTL level serial (9600 baud, 8-bits, 1-stop, no-parity, Tx, Rx and CTS)
Communication Parameters via USB interface	VCP (Virtual COM Port) 9600 baud, 8 data bits, no parity, 1 stop bit protocol with CTS handshake

No responsibility is taken for the method of integration or final use of MicroRWD

More information on the Micro RWD and other products can be found at the Internet web site:

<http://www.ibtechnology.co.uk>

Or alternatively contact IB Technology by email at:

sales@ibtechnology.co.uk