



RVT28AEFNWC00

LCD TFT Datasheet

Rev.1.1

2015-10-06

ITEM	CONTENTS	UNIT
LCD Type	TFT/Transmissive/Normally white	/
Size	2.83	Inch
Viewing Direction	6:00 (without image inversion)	O' Clock
Gray Scale Inversion Direction	12:00	O' Clock
LCM (W × H × D)	50.20 x 69.30 x 7.92	mm3
Active Area (W × H)	43.20 × 57.60	mm2
Dot Pitch (W × H)	0.18 × 0.18	mm2
Number Of Dots	240 x (RGB) × 320	/
Driver IC	FT801	/
Backlight Type	4 LEDs	/
Surface Luminance	255	cd/m2
Interface Type	SPI/I2C	/
Color Depth	262K	/
Pixel Arrangement	RGB Vertical Stripe	/
Surface Treatment	Clear	
Input Voltage	2.8	V
With/Without TSP	Projected Capacitive Touch Panel	/
Weight	41.67	g

Note 1: RoHS compliant

Note 2: LCM weight tolerance: ± 5%.

REVISION RECORD

REVNO.	REVDATE	CONTENTS	REMARKS
1.0	2015-08-24	Initial Release	
1.1	2015-10-06	Update PCB position in mechanical drawing	

CONTENTS

REVISION RECORD.....	2
CONTENTS	2
1 MODULE CLASSIFICATION INFORMATION	3
2 MODULE DRAWING	4
3 ABSOLUTE MAXIMUM RATINGS.....	5
4 ELECTRICAL CHARACTERISTICS.....	5
5 BACKLIGHT CHARACTERISTICS	5
6 ELECTRO-OPTICAL CHARACTERISTICS	6
7 INTERFACE DESCRIPTION	8
8 FT801 CONTROLLER SPECIFICATIONS	9
8.1 Serial host interface.....	9
8.2 Block Diagram.....	10
8.3 Host interface SPI mode 0	10
8.4 Backlight driver block diagram	10
9 LCD TIMING CHARACTERISTICS	11
9.1 Clock and data input time diagram	11
9.2 Parallel RGB input timing table	11
10 INITIAL CODE	12
11 CAPACITIVE TOUCH SCREEN PANEL SPECIFICATIONS	16
11.1 Mechanical characteristics	16
11.2 Electrical characteristics	16
12 RELIABILITY TEST.....	17
13 LEGAL INFORMATION.....	18

1 MODULE CLASSIFICATION INFORMATION

RV	T	28	A	E	F	N	W	C	00
1.	2.	3.	4.	5.	6.	7.	8.	9.	10.

1.	BRAND	RV – Riverdi
2.	PRODUCT TYPE	T – TFT Standard F – TFT Custom
3.	DISPLAY SIZE	28 – 2.83” 35 – 3.5” 43 – 4.3” 70 – 7.0”
4.	MODEL SERIAL NO.	A (A-Z)
5.	RESOLUTION	E– 240x320 px
6.	INTERFACE	T – TFT LCD, RGB L – TFT LCD, LVDS S – TFT + Controller SSD1963 F – TFT + Controller FT801
7.	FRAME	N – No Frame F – Mounting Frame
8.	BACKLIGHT TYPE	W – LED White
9.	TOUCH PANEL	N – No Touch Panel R – Resistive Touch Panel C – Capacitive Touch Panel
10.	VERSION	00(00-99)

PIN	DESC
1	VDD
2	GND
3	SPI_SCLK/ I2C_SCL
4	MISO/I2C_SDA
5	MOSI/I2C_SA0
6	CS/I2C_SA1
7	INT
8	PD
9	MODE
10	AUDIO_OUT
11	NC
12	NC
13	NC
14	NC
15	NC
16	NC
17	BLVDD
18	BLVDD
19	BLGND
20	BLGND

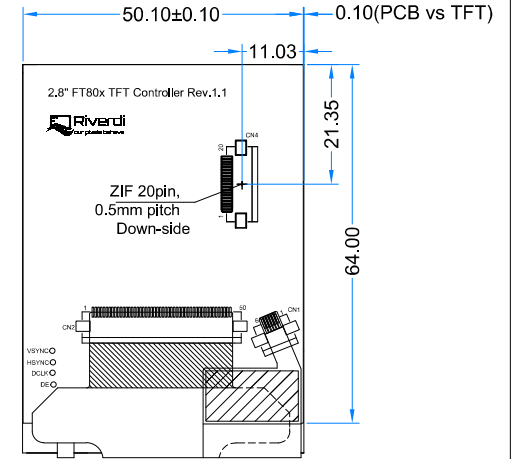
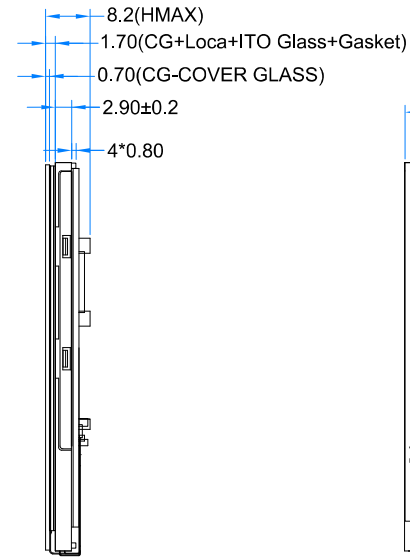
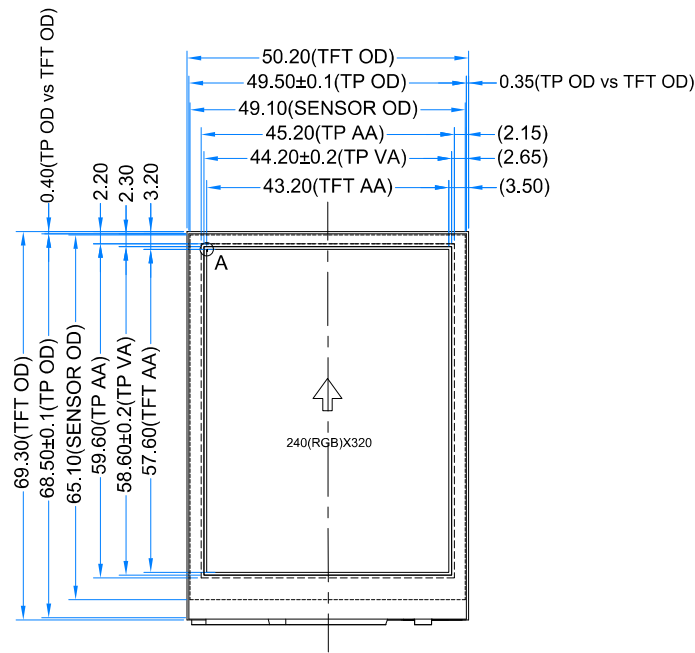

NOTES:

1. DISPLAY TYPE: TFT, TRANSMISSIVE, NORMALY WHITE
2. 2.83 INCH CAPACITIVE TOUCH PANEL
3. VIEWING DIRECTION: 6 O'CLOCK
4. OPERATION VOLTAGE: VDD= 2.8V
5. IC CONTROLLER: FT801, BUILT-IN INVERTER
6. CTP IC DRIVER: FT6206
7. CTP RESOLUTION 240x320 DOTS
8. CTP MULTIFINGER: UP TO 2- TOUCH GESTURE
9. LED BACKLIGHT: 4-LED WHITE
10. SURFACE LUMINANCE: 255 cd/m²
11. OPERATING TEMP: -20°C ~ +70°C
12. STORAGE TEMP: -30°C ~+80°C
13. GENERAL TOLERANCE: ±0.20
14. RoHS COMPLIANT

DETAIL A
SCALE 20:1

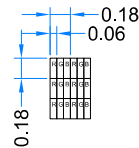

INTERNAL BACKLIGHT CIRCUIT DIAGRAM

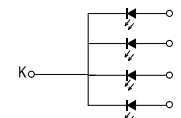

CTP PINOUT	
1	TP_VDD
2	TP_RES
3	TP_INT
4	TP_SDA
5	TP_SCK
6	TP_GND

Rev.	DESCRIPTION	DATE
1.1	Update PCB position	2015.10.06
1.0	Initial case	2015.08.21

CUSTOMER		DATE	2015/10/06
DRAWN	SCALE	1:1	TITLE
DFTG CHK	UNIT	mm	RVT28AEFNWC00
ENGR CHK	APPROVAL		MODEL
			DWG NO
			Rev.1.1
			PAGE
			1/1

3 ABSOLUTE MAXIMUM RATINGS

PARAMETER	SYMBOL	MIN	MAX	UNIT
Supply Voltage For LCD Logic	VDD	-0.3	4.6	V
Logic signal voltage	VDD	-0.3	4.6	V
Operating Temperature	T _{OP}	-20	70	°C
Storage Temperature	T _{ST}	-30	80	°C
Humidity	RH	-	90% (Max 60°C)	RH

4 ELECTRICAL CHARACTERISTICS

PARAMETER	SYMBOL	MIN	TYP	MAX	UNIT
Power Supply Voltage For LCD Logic	VDD	2.5	2.8	3.3	V
Supply Voltage For CTP Logic	VDD	2.8	3.0	3.3	V
Input Current	IDD	-	22	-	mA
Input Voltage ' H ' level	V _{IH}	0.7VDD	-	VDD	V
Input Voltage ' L ' level	V _{IL}	GND	-	0.3VDD	V
Output Voltage ' H ' level	V _{OH}	0.8VDD	-	VDD	V
Output Voltage ' L ' level	V _{OL}	GND	-	0.2VDD	V

5 BACKLIGHT CHARACTERISTICS

ITEM	SYMBOL	MIN	TYP	MAX	UNIT
Voltage for LED backlight	V _f	-	3.2	3.4	V
Current for LED backlight	I _f	-	89	-	mA
LED Life Time	-	30000	40000	-	Hrs

Note:

1. The LED life time is defined as the module brightness decrease to 50% original brightness at Ta=25°C, 60%RH ±5 %.
2. The life time of LED will be reduced if LED is driven by high current, high ambient temperature and humidity conditions.
3. Typical operating life time is an estimated data.
4. Permanent damage to the device may occur if maximum values are exceeded or reverse voltage is loaded. Functional operation should be restricted to the conditions described under normal operating conditions.

6 ELECTRO-OPTICAL CHARACTERISTICS

ITEM	SYMBOL	CONDITION	MIN	TYP	MAX	UNIT	REMARK	NOTE
Response Time	Tr+Tf	$\theta=0^\circ$ $\phi=0^\circ$ Ta=25	-	25	30	ms	Figure 1	4
Contrast Ratio	Cr		-	500	-	---	Figure 2	1
Luminance Uniformity	δ WHITE		80	90	-	%	Figure 2	3
Surface Luminance	Lv		-	255	-	cd/m ²	Figure 2	2
Viewing Angle Range	θ	$\phi = 90^\circ$	-	70	-	deg	Figure 3	6
		$\phi = 270^\circ$	-	57	-	deg	Figure 3	
		$\phi = 0^\circ$	-	70	-	deg	Figure 3	
		$\phi = 180^\circ$	-	70	-	deg	Figure 3	
CIE (x, y) Chromaticity	Red	$\theta=0^\circ$ $\phi=0^\circ$ Ta=25	x	-	0.6368	-	Figure 2	5
			y	-	0.3329	-		
	Green		x	-	0.3397	-		
			y	-	0.6138	-		
	Blue		x	-	0.1433	-		
			y	-	0.0807	-		
	White		x	-	0.2886	-		
			y	-	0.3194	-		
NTSC	-	S	-	55	67	-	%	-

Note 1. Contrast Ratio(CR) is defined mathematically as below, for more information see Figure 1

$$\text{Contrast Ratio} = \frac{\text{Average Surface Luminance with all white pixels (P1, P2, P3, P4, P5)}}{\text{Average Surface Luminance with all black pixels (P1, P2, P3, P4, P5)}}$$

Note 2. Surface luminance is the LCD surface from the surface with all pixels displaying white. For more information see Figure 2.

Lv = Average Surface Luminance with all white pixels (P1, P2, P3, P4, P5)

Note 3. The uniformity in surface luminance δ WHITE is determined by measuring luminance at each test position 1 through 5, and then dividing the maximum luminance of 5 points luminance by minimum luminance of 5 points luminance. For more information see Figure 2.

$$\delta \text{ WHITE} = \frac{\text{Minimum Surface Luminance with all white pixels (P1, P2, P3, P4, P5)}}{\text{Maximum Surface Luminance with all white pixels (P1, P2, P3, P4, P5)}}$$

Note 4. Response time is the time required for the display to transition from white to black (Rise Time, Tr) and from black to white (Decay Time, Tf). For additional information see FIG 1. The test equipment is Autronic-Melchers's ConoScope series.

Note 5. CIE (x, y) chromaticity, the x, y value is determined by measuring luminance at each test position 1 through 5, and then make average value.

Note 6. Viewing angle is the angle at which the contrast ratio is greater than 2. For TFT module the contrast ratio is greater than 10. The angles are determined for the horizontal or x axis and the vertical or y axis with respect to the z axis which is normal to the LCD surface. For more information see Figure 3.

Note 7. For viewing angle and response time testing, the testing data is based on Autronic-Melchers’s ConoScope series. Instruments for Contrast Ratio, Surface Luminance, Luminance Uniformity, CIE the test data is based on TOPCON’s BM-5 photo detector.

Figure 1. The definition of response time

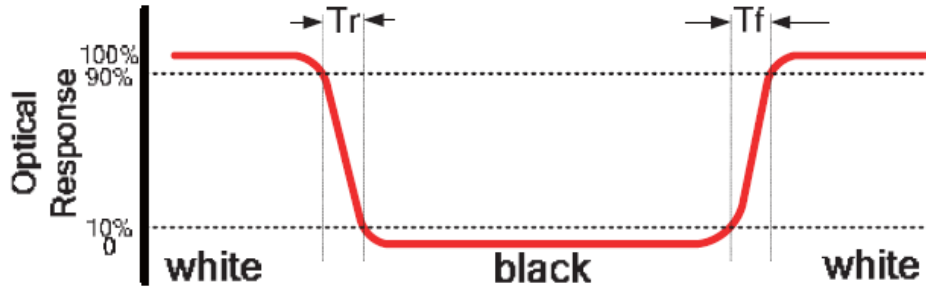

Figure 2. Measuring method for Contrast ratio, surface luminance, Luminance uniformity, CIE (x, y) chromaticity

A : 5 mm
 B : 5 mm
 H, V : Active Area
 Light spot size $\varnothing=5\text{mm}$, 500mm distance from the LCD surface to detector lens
 measurement instrument is TOPCON’s luminance meter BM-5

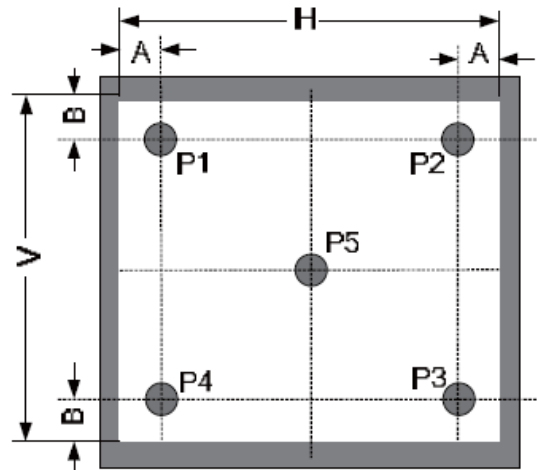
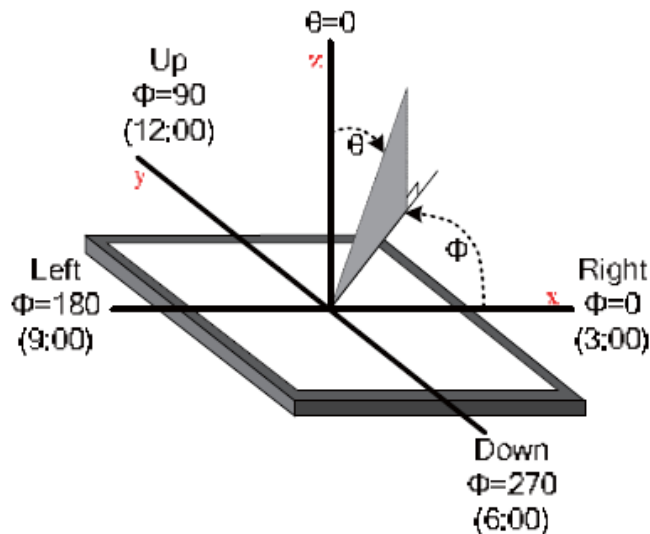

Figure 3. The definition of viewing angle



7 INTERFACE DESCRIPTION

PIN NO.	SYMBOL	DESCRIPTION
1	VDD	Power Supply
2	GND	Ground
3	SPI_SCLK/ I2C_SCL	SPI SCK Signal / I2C SCL Signal, Internally 47k Pull UP
4	MISO/ I2C_SDA	SPI MISO Signal / I2C SDA Signal, Internally 47k Pull UP
5	MOSI/ I2C_SA0	SPI MOSI Signal / I2C Slave Address Bit 0, Internally 47k Pull UP
6	CS/I2C_SA1	SPI Chip Select Signal / I2C Slave Address Bit 1, Internally 47k Pull UP
7	INT	Interrupt Signal, Active Low, Internally 47k Pull UP
8	PD	Power Down Signal, Active Low, Internally 47k Pull UP
9	MODE	Host Interface SPI(Pull Low) or I2C(Pull Up) Mode Select Input, Internally 10k Pull DOWN
10	AUDIO_OUT	Audio Out Signal
11	NC	Not Connected
12	NC	Not Connected
13	NC	Not Connected
14	NC	Not Connected
15	NC	Not Connected
16	NC	Not Connected
17	BLVDD	Backlight Power Supply, Can Be Connected to VDD
18	BLVDD	Backlight Power Supply, Can Be Connected to VDD
19	BLGND	Backlight Ground, Internally connected to GND
20	BLGND	Backlight Ground, Internally connected to GND

8 FT801 CONTROLLER SPECIFICATIONS

FT801 or EVE (Embedded Video Engine) simplifies the system architecture for advanced human machine interfaces (HMIs) by providing functionality for display, audio, and touch as well as an object oriented architecture approach that extends from display creation to the rendering of the graphics.

8.1 Serial host interface

Figure 4. SPI interface connection

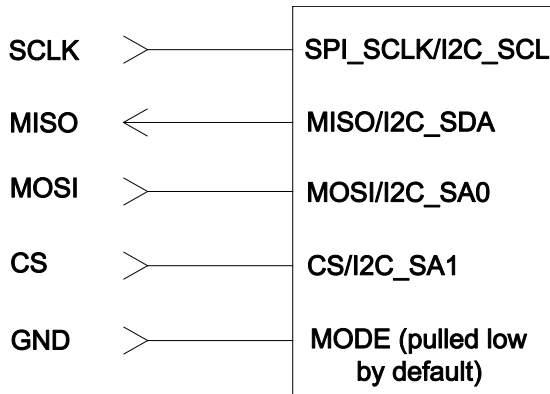
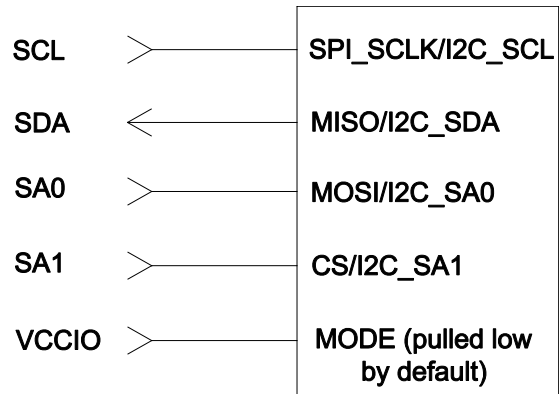

Figure 5. I2C interface connection



SPI Interface – the SPI slave interface operates up to 30MHz.

Only SPI mode 0 is supported. The SPI interface is selected by default (MODE pin is internally pulled low by 47k resistor).

I²C Interface – the I²C slave interface operates up to 3.4MHz, supporting standard-mode, fast-mode, fast-mode plus and high-speed mode.

The I²C device address is configurable between 20h to 23h depending on the I²C_SA[1:0] pin setting, i.e. the 7-bit I²C slave address is 0b'01000A1A0.

The I²C interface is selected when the MODE pin is tied to VDDIO.

8.2 Block Diagram

Figure 6. FT801 Block diagram

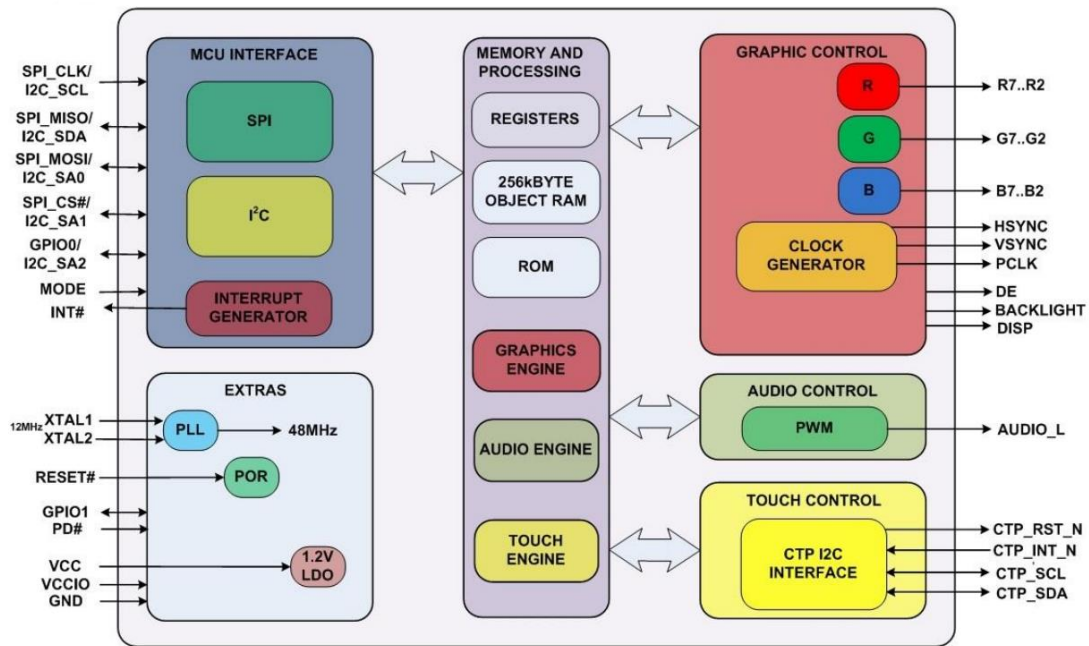

8.3 Host interface SPI mode 0

Figure 7. SPI timing diagram

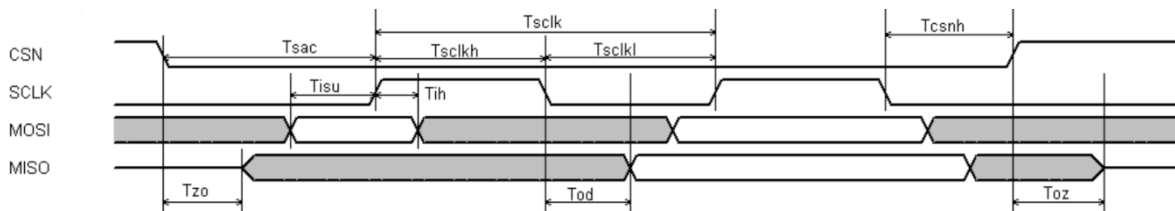

For more information about FT801 controller please go to official FT801 Datasheet.
http://www.ftdichip.com/Support/Documents/DataSheets/ICs/DS_FT801.pdf

8.4 Backlight driver block diagram

Backlight enable signal is internally connected to FT801 Backlight control pin. This pin is controlled by two FT801's registers. One of them specifies the PWM output frequency, second one specifies the duty cycle. Refer to FT801 datasheet for more information.

Figure 8. Backlight driver block diagram

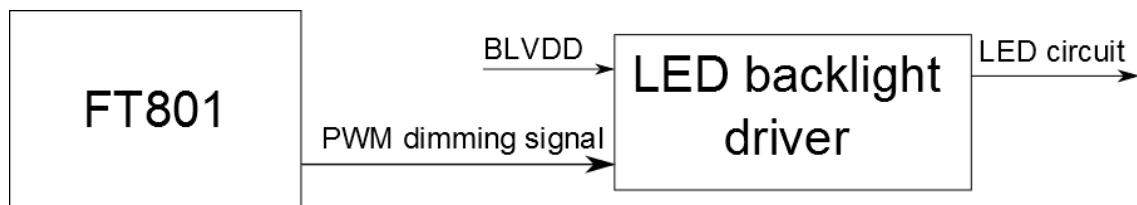

9 LCD TIMING CHARACTERISTICS

9.1 Clock and data input time diagram

Figure 9. Clock and data input time diagram

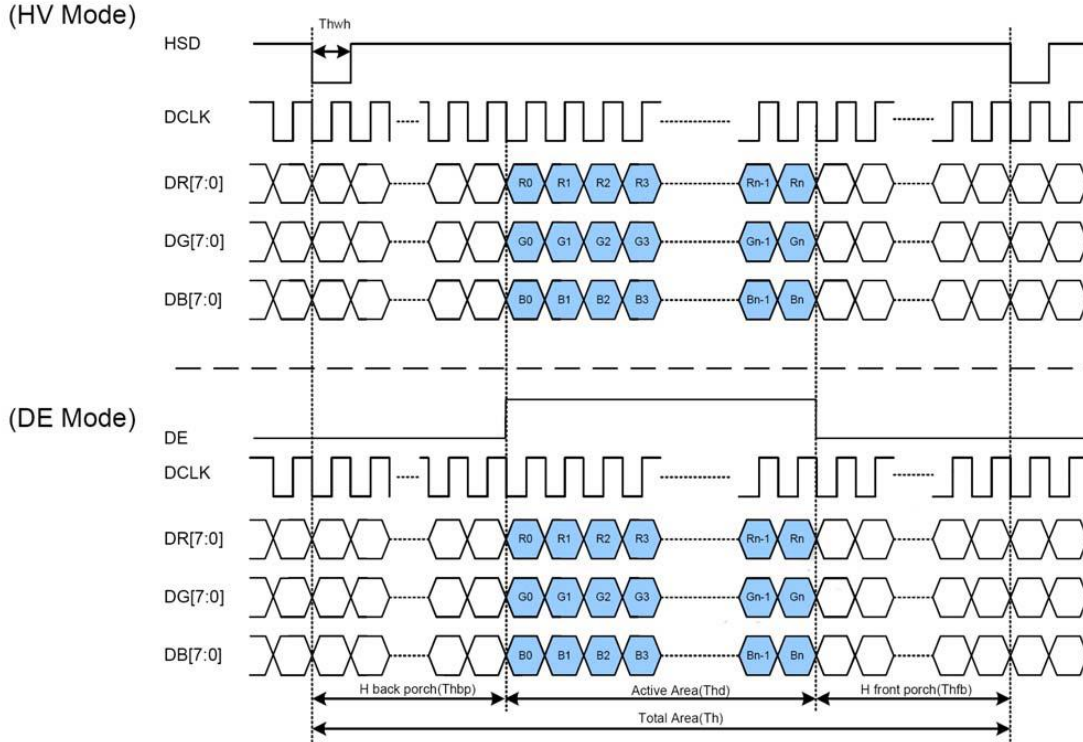

9.2 Parallel RGB input timing table

PARAMETER	SYMBOL	MIN	TYP	MAX	UNIT
DCLK Frequency	Fclk	-	6.35	-	MZH
VSD Period Time	Tv	324	326	320	H
VSD Display Area	Tvd		320		H
VSD Back Porch	Tvbp	1	2	-	H
VSD Front Porch	Tvfp	3	4	-	H
HSD Period Time	Th	244	270	280	DCLK
HSD Display Area	Thd		240		DCLK
HSD Back Porch	Thbp	2	20	24	DCLK
HSD Front Porch	Thfp	2	10	16	DCLK

10 INITIAL CODE

```

#define REG_GPIO      1057936UL
#define REG_GPIO_DIR 1057932UL

//Function which sends SPI (8-bit) data to FT80X
void SPI_FT_Send(uint8_t data)

{
    unsigned char m=0x80;

    for(i=0;i<8;i++)
    {
        GPIO_WriteBit(CLK,0);
        if(data&m)
        {
            GPIO_WriteBit(SDO,1);
        }
        else
        {
            GPIO_WriteBit(SDO,0);
        }
        GPIO_WriteBit(CLK,1);

        m=m>>1;
        GPIO_WriteBit(CLK,0);
    }
}

//Function which sets the CS for ILI9341 through FT80X registers
void CS_ILI(uint8_t mode)

{
    switch (mode) {
        case 0:
            GPIO_WriteBit(FT_CS,0);

            SPI_FT_Send(((REG_GPIO >> 16) & 0xBF | 0x80));
            SPI_FT_Send((REG_GPIO & 0xFF00) >> 8);
            SPI_FT_Send((REG_GPIO & 0xFF));

            SPI_FT_Send(0x00);

            GPIO_WriteBit(FT_CS,1);
            break;
        case 1:
            GPIO_WriteBit(FT_CS,0);

            SPI_FT_Send(((REG_GPIO >> 16) & 0xBF | 0x80));
            SPI_FT_Send((REG_GPIO & 0xFF00) >> 8);
            SPI_FT_Send((REG_GPIO & 0xFF));

            SPI_FT_Send(0x83);

            GPIO_WriteBit(GPIOA,FT_CS,1);
            GPIO_WriteBit(SDO,0);
            GPIO_WriteBit(CLK,0);
            break;
    }
}

//Function which sends SPI (9-bit) data to ILI9341
void ILI_Send(DC type, uint8_t data)
{
    unsigned char m=0x80;
    uint8_t i, test;
    if(type == COMMAND)

```

```

    {
        GPIO_WriteBit(CLK, 0);
        GPIO_WriteBit(SDO, 0);
        GPIO_WriteBit(CLK, 1);
    }
    else if(type == DATA)
    {
        GPIO_WriteBit(CLK, 0);
        GPIO_WriteBit(SDO, 1);
        GPIO_WriteBit(CLK, 1);
    }
    for(i=0;i<8;i++)
    {
        GPIO_WriteBit(CLK, 0);
        if(data&m)
        {
            GPIO_WriteBit(SDO, 1);
        }
        else
        {
            GPIO_WriteBit(SDO, 0);
        }
        GPIO_WriteBit(CLK, 1);

        m=m>>1;
    }
    delay_ms(1);
}
void ILI_init()
{
    FT80X_init(); //FT80X initialization
    Ft_Gpu_Hal_Sleep(5000);
    CS_ILI(0);
    ILI_Send(COMMAND, 0x01); //software reset
    delay_ms(5);
    CS_ILI(1);

    CS_ILI(0);
    ILI_Send(COMMAND, 0x28); //display off
    CS_ILI(1);
//-----
    CS_ILI(0);
    ILI_Send(COMMAND, 0xcf);
    ILI_Send(DATA, 0x00);
    ILI_Send(DATA, 0x81);
    ILI_Send(DATA, 0x30);
    CS_ILI(1);

    CS_ILI(0);
    ILI_Send(COMMAND, 0xed);
    ILI_Send(DATA, 0x64);
    ILI_Send(DATA, 0x03);
    ILI_Send(DATA, 0x12);
    ILI_Send(DATA, 0x81);
    CS_ILI(1);

    CS_ILI(0);
    ILI_Send(COMMAND, 0xe8);
    ILI_Send(DATA, 0x85);
    ILI_Send(DATA, 0x01);
    ILI_Send(DATA, 0x79);
    CS_ILI(1);

    CS_ILI(0);
    ILI_Send(COMMAND, 0xcb);
    ILI_Send(DATA, 0x39);
    ILI_Send(DATA, 0x2c);
    ILI_Send(DATA, 0x00);

```

```

ILI_Send(DATA,0x34);
ILI_Send(DATA,0x02);
CS_ILI(1);

CS_ILI(0);
ILI_Send(COMMAND,0xF6); //Interface Control
ILI_Send(DATA,0x01);
ILI_Send(DATA,0x00);
ILI_Send(DATA,0x06);
CS_ILI(1);

CS_ILI(0);
ILI_Send(COMMAND,0xf7);
ILI_Send(DATA,0x20);
CS_ILI(1);

CS_ILI(0);
ILI_Send(COMMAND,0xea);
ILI_Send(DATA,0x06);
ILI_Send(DATA,0x00);
CS_ILI(1);
//-----power control-----

CS_ILI(0);
ILI_Send(COMMAND,0xc0); //power control
ILI_Send(DATA,0x26);
CS_ILI(1);

CS_ILI(0);
ILI_Send(COMMAND,0xc1); //power control
ILI_Send(DATA,0x11);
CS_ILI(1);
//-----VCOM -----

CS_ILI(0);
ILI_Send(COMMAND,0xc5); //vcom control
ILI_Send(DATA,0x35);
ILI_Send(DATA,0x3E);
CS_ILI(1);

CS_ILI(0);
ILI_Send(COMMAND,0xc7); //vcom control
ILI_Send(DATA,0xBE);
CS_ILI(1);
//-----memory access control-----

CS_ILI(0);
ILI_Send(COMMAND,0x36);
ILI_Send(DATA,0x40);
CS_ILI(1);

CS_ILI(0);
ILI_Send(COMMAND,0x3a); //pixel format set
ILI_Send(DATA,0x60); //18bit /pixel
CS_ILI(1);
//----- frame rate-----

CS_ILI(0);
ILI_Send(COMMAND,0xb0); //RGB Interface Signal Control
ILI_Send(DATA,0xc0); //0x1c0 DE mode
CS_ILI(1);

CS_ILI(0);
ILI_Send(COMMAND,0xb1); //frame rate
ILI_Send(DATA,0x00);
ILI_Send(DATA,0x1B);
CS_ILI(1);
//-----Gamma-----

```

```

CS_ILI(0);
ILI_Send(COMMAND,0xf2); //3Gamma Function Disable
ILI_Send(DATA,0x02);
CS_ILI(1);

CS_ILI(0);
ILI_Send(COMMAND,0x26);
ILI_Send(DATA,0x01); //gamma set 4 gamma curve 01/02/04/08
CS_ILI(1);

CS_ILI(0);
ILI_Send(COMMAND,0xE0); //positive gamma correction
ILI_Send(DATA,0x1f);
ILI_Send(DATA,0x1a);
ILI_Send(DATA,0x18);
ILI_Send(DATA,0x0a);
ILI_Send(DATA,0x0f);
ILI_Send(DATA,0x06);
ILI_Send(DATA,0x45);
ILI_Send(DATA,0x87);
ILI_Send(DATA,0x32);
ILI_Send(DATA,0x0a);
ILI_Send(DATA,0x07);
ILI_Send(DATA,0x02);
ILI_Send(DATA,0x07);
ILI_Send(DATA,0x05);
ILI_Send(DATA,0x00);
CS_ILI(1);

CS_ILI(0);
ILI_Send(COMMAND,0xE1); //negamma correction
ILI_Send(DATA,0x00);
ILI_Send(DATA,0x25);
ILI_Send(DATA,0x27);
ILI_Send(DATA,0x05);
ILI_Send(DATA,0x10);
ILI_Send(DATA,0x09);
ILI_Send(DATA,0x3a);
ILI_Send(DATA,0x78);
ILI_Send(DATA,0x4d);
ILI_Send(DATA,0x05);
ILI_Send(DATA,0x18);
ILI_Send(DATA,0x0d);
ILI_Send(DATA,0x38);
ILI_Send(DATA,0x3a);
ILI_Send(DATA,0x1f);
CS_ILI(1);

CS_ILI(0);
ILI_Send(COMMAND,0x11); //sleep out
delay_ms(100);
CS_ILI(1);

CS_ILI(0);
ILI_Send(COMMAND,0x29); //display on
delay_ms(50);
CS_ILI(1);
}

```

11 CAPACITIVE TOUCH SCREEN PANEL SPECIFICATIONS

Capacitive Touch Panel is directly connected to FT801 module. Therefore communication with Capacitive touch panel is simplified to read registers of FT801.

Figure 10. Capacitive Touch Panel Connection

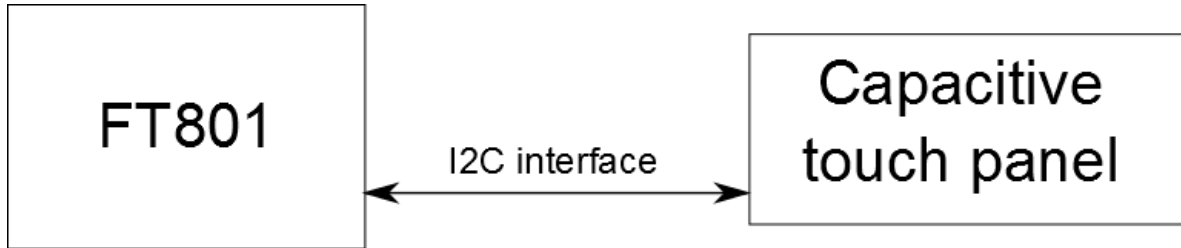

11.1 Mechanical characteristics

DESCRIPTION	INL SPECIFICATION	REMARK
Touch Panel Size	2.83 inch	
Outline Dimension (OD)	49.5mm x 68.75mm	Cover Lens Outline
Product Thickness	1.675mm	
Glass Thickness	0.70mm	
Ink View Area	44.2mm x 58.6mm	
Sensor Active Area	45.20mm x 59.60mm	
Input Method	2 Fingers	
Activation Force	Touch	
Surface Hardness	≥6H	

11.2 Electrical characteristics

DESCRIPTION	SPECIFICATION	
Operating Voltage	DC 2.8~3.3V	
Power Consumption (IDD)	Active Mode	12~4.5mA
	Sleep Mode	TBD
Interface	I ² C	
Controller	FT6206	
I2C address	0x38 (7 bit address)	
Resolution	240*320	

12 RELIABILITY TEST

NO.	TEST ITEM	TEST CONDITION	INSPECTION AFTER TEST
1	High Temperature Storage	80±2°C/96 hours	<p>Inspection after 2~4 hours storage at room temperature and humidity. The condensation is not accepted. The sample shall be free from defects:</p> <ol style="list-style-type: none"> 1. Air bubble in the LCD 2. Seal leak 3. Non-display 4. Missing segments 5. Glass crack
2	Low Temperature Storage	-30±2°C/96 hours	
3	High Temperature Operating	70±2°C/96 hours	
4	Low Temperature Operating	-20±2°C/96 hours	
5	Temperature Cycle	-30±2°C ~ 25~ 80± 2°C × 10 cycles (30 min.) (5min.) (30min.)	
6	Damp Proof Test	60°C ±5°C × 90%RH/96 hours	
7	Vibration Test	Frequency 10Hz~55Hz Stroke: 1.5mm Sweep: 10Hz~150 Hz~10Hz 2 hours For each direction of X, Y, Z	
8	Shock Test	Half-sine, wave, 300m/s	
9	Packing Drop Test	Height: 80 cm 1 corner, concrete floor	
11	Electrostatic Discharge Test	C=150pF, R=330 Ω Air: ±8KV 150pF/330Ω 30 times Contact: ±4KV,20 times	

13 LEGAL INFORMATION

Riverdi makes no warranty, either expressed or implied with respect to any product, and specifically disclaims all other warranties, including, without limitation, warranties for merchantability, non-infringement and fitness for any particular purpose. Information about device are the property of Riverdi and may be the subject of patents pending or granted. It is not allowed to copy or disclosed this document without prior written permission.

Riverdi endeavors to ensure that the all contained information in this document are correct but does not accept liability for any error or omission. Riverdi products are in developing process and published information may be not up to date. Riverdi reserves the right to update and makes changes to Specifications or written material without prior notice at any time. It is important to check the current position with Riverdi.

Images and graphics used in this document are only for illustrative the purpose. All images and graphics are possible to be displayed on the range products of Riverdi, however the quality may vary. Riverdi is no liable to the buyer or to any third part for any indirect, incidental, special, consequential, punitive or exemplary damages (including without limitation lost profits, lost savings, or loss of business opportunity) relating to any product, service provided or to be provided by Riverdi, or the use or inability to use the same, even if Riverdi has been advised of the possibility of such damages.

Riverdi products are not fault tolerant nor designed, manufactured or intended for use or resale as on line control equipment in hazardous environments requiring fail – safe performance, such as in the operation of nuclear facilities, aircraft navigation or communication systems, air traffic control, direct life support machines or weapons systems in which the failure of the product could lead directly to death, personal injury or severe physical or environmental damage ('High Risk Activities'). Riverdi and its suppliers specifically disclaim any expressed or implied warranty of fitness for High Risk Activities. Using Riverdi products and devices in 'High Risk Activities' and in any other application is entirely at the buyer's risk, and the buyer agrees to defend, indemnify and hold harmless Riverdi from any and all damages, claims or expenses resulting from such use. No licenses are conveyed, implicitly or otherwise, under any Riverdi intellectual property rights.

