

SENSOR SWITCH

Item No.	RBS020902T	Description	Tilt Sensor Switch	Version	14
Page	1 of 9		Date	Jan. 08, 2018	

● **FUNCTIONS**

1. Horizontal Tilt Detecting
2. Vertical Rotation Detecting
3. Shock Detecting



● **APPLICATIONS**

1. Screen Rotation
2. Web Camera
3. Alarm System
4. Iron Position Detecting
5. Bicycle lights flashing
6. Step Counter

● **FEATURES**

1. Suitable for horizontal PCB.
2. Switch state: Normal Open.
3. Tiny size, suitable for small space.
4. Wing-shaped terminals, a feature enables half body of the sensor switch to be buried into PCB.
5. Gold-plated ball and terminals, low possibility of oxidization.
6. All plastic materials subject to industrial purpose, resist high temperature and meet fireproof function.
7. Simple ON and OFF signals, easy for design.
8. RoHS compliance, an ideal substitute for mercury switch.
9. A more economical tilt and rotation detection option than IC design solution.
10. All made in Taiwan and examined before shipment

● **PATENTS**

1. TAIWAN Patent NO.390563
2. CHINA Patent NO.ZL 200710123228.X



SENSOR SWITCH

Item No.	RBS020902T	Description	Tilt Sensor Switch	Version	14
Page	2 of 9		Date	Jan. 08, 2018	

● DIMENSIONS / OPERATION / P.C.B. LAYOUT (Unit: mm, Tolerance: ±0.25mm)

Fig. 1

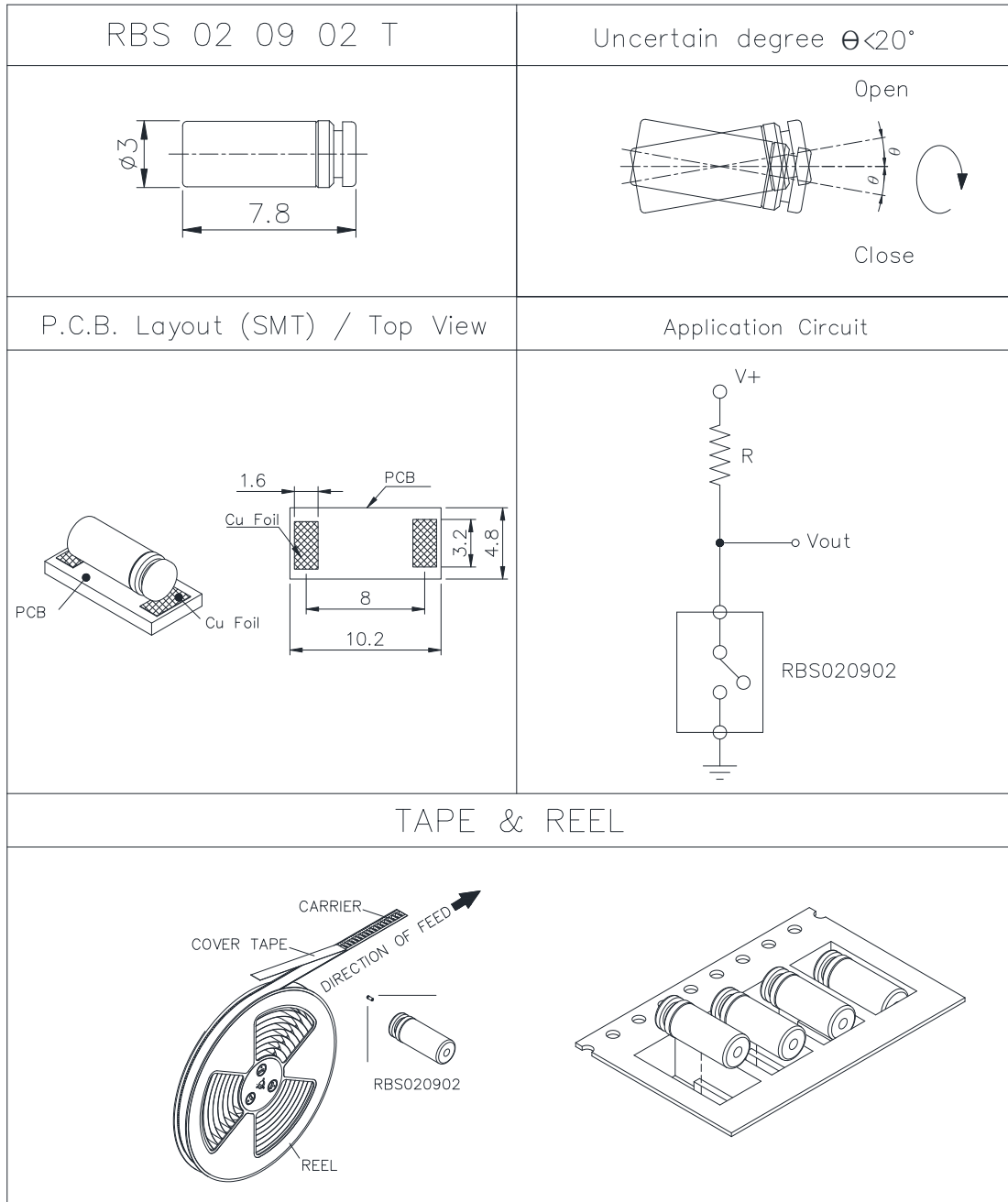

SENSOR SWITCH

Item No.	RBS020902T	Description	Tilt Sensor Switch	Version	14
Page	3 of 9		Date	Jan. 08, 2018	

● Current/Voltage Suggested

Input Current (mA)	Operating Voltage (V)	Condition
1.0	5	--

● ELECTRICAL CHARACTERISTICS

1.	Contact Rating	10mA, 5VDC
2.	Contact Resistance	10Ω max.
3.	Angle Tolerance	Refer to Fig. 1
4.	Insulation Resistance	50MΩ min. at 100VDC
5.	Dielectric Strength	50VDC min. for 1 minute
6.	Capacitance	5pF max.
7.	Conductive Rate	85% min.



SENSOR SWITCH

Item No.	RBS020902T	Description	Tilt Sensor Switch	Version	14
Page	4 of 9		Date	Jan. 08, 2018	

● RELIABLE TEST ITEMS

Reliable Test for RBS020902T

Test Item	Standard	Contents
IR Reflow	MIL-STD-202G, TEST METHOD 210F、 IPC/JEDEC J-STD-020D	Peak temp.=255~260°C*3times
Operating Temperature	MIL-STD-202G, TEST METHOD 107G, TEST A	-25°C~85°C
Storage Temperature	MIL-STD-202G, TEST METHOD 107G, TEST A	-40°C~85°C
Humidity	MIL-STD-202G, TEST METHOD 103B	40°C/95%RH
Mechanical Life	--	2 Hz, horizontal 1,000,000 times
Electrical Life	--	100,000 times



SENSOR SWITCH

Item No.	RBS020902T	Description	Tilt Sensor Switch	Version	14
Page	5 of 9		Date	Jan. 08, 2018	

● **SOLDERING CONDITION**

Following soldering conditions are for reference only, please use soldering information that solder paste manufacturer recommends.

Condition Operation Method	Soldering Temperature	Soldering Time	Wattage of Manual Soldering	Suitable Production Process
IR Reflow	Please refer to following < Table of classification Reflow profile > and Fig. 2		-	SMT
Manual Soldering	300±5°C	< 3 seconds max.	30W or Temperature-controlled manual soldering	SMT



SENSOR SWITCH

Item No.	RBS020902T	Description	Tilt Sensor Switch	Version	14
Page	6 of 9		Date	Jan. 08, 2018	

< Table of classification Reflow profile >

Item	Pb process	Pb free process
Pre-heat and Soak Temperature min.(T _{min}) Temperature max.(T _{max}) Time (T _{min} to T _{max})(t _s)	100 °C 150 °C 60-120 seconds	150 °C 200 °C 60-120 seconds
Average Rate of temperature rising up (T _{max} to T _p)	3 °C/second max.	3 °C/second max.
Liquidous Temperature (T _L) Time at Liquidous (t _L)	183 °C 60-150 seconds	217 °C 60-150 seconds
Peak package body Temperature (T _p)*	230 °C ~235 °C *	255 °C ~260 °C *
Classification temperature(T _c)	235 °C	260 °C
Time(tp)** within 5 °C of the specified classification temperature (T _c)	20** seconds	30** seconds
Average ram-down Rate (T _p to T _{max})	6 °C/second max.	6 °C/second max.
Time 25 °C to peak temperature	6 minutes max.	8 minutes max.
* Tolerance for peak profile temperature (T _p) is defined as a supplier minimum and a user maximum. ** Tolerance for time at peak profile temperature (tp) is defined as a supplier minimum and a user maximum.		



SENSOR SWITCH

Item No.	RBS020902T	Description	Tilt Sensor Switch	Version	14
Page	7 of 9		Date	Jan. 08, 2018	

Fig. 2

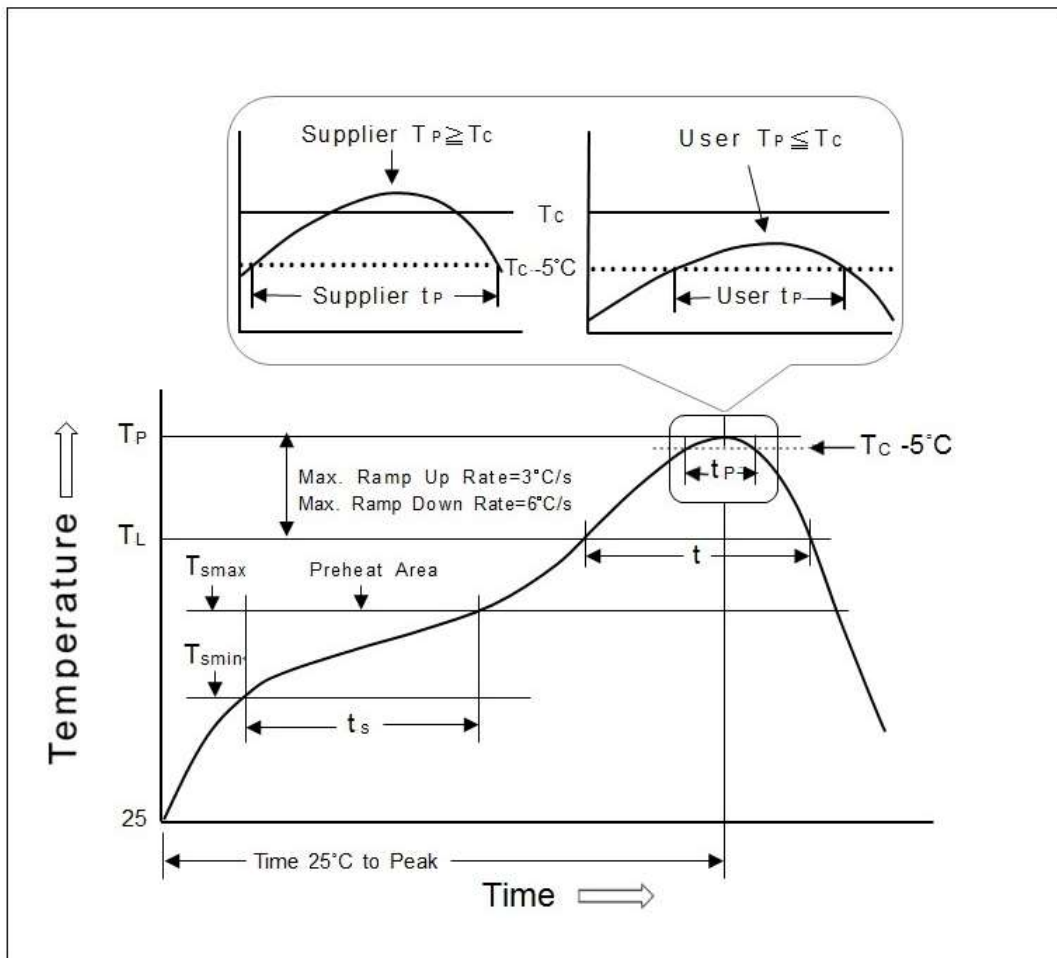

SENSOR SWITCH

Item No.	RBS020902T	Description	Tilt Sensor Switch	Version	14
Page	8 of 9		Date	Jan. 08, 2018	

● PACKAGE

	Part Number	Package	Quantity	Total Q'ty	Dimension(mm)
1.	RBS020902	PE Bag	2,000 pcs	2,000 pcs	205L*145W
		Inner Box	10 PE Bag	20,000 pcs	348L*191W*85H
		Carton	3 Boxes	60,000 pcs	364L*278W*213H

※ Package shown as below for reference.



	Part Number	Package	Quantity	Total Q'ty	Dimension(mm)
2.	RBS020902T	Tape & reel	2,500 pcs	2,500 pcs	φ330*25H
		Inner Box	2 Reels	5,000 pcs	355L*340W*68H
		Carton	4 Boxes	20,000 pcs	373L*358W*309H

※ Package shown as below for reference.

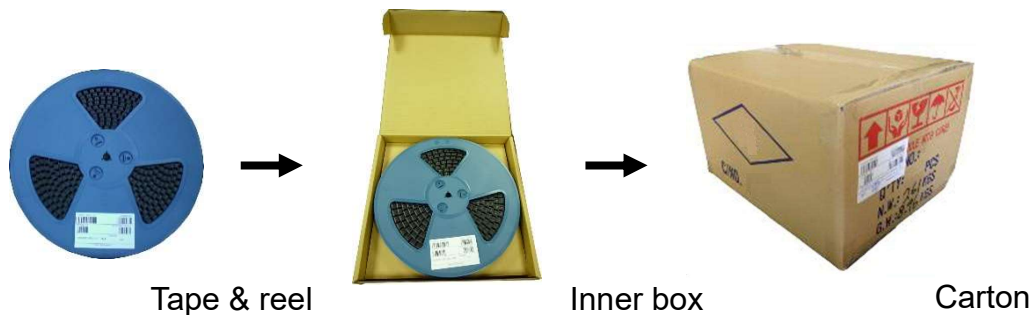

SENSOR SWITCH

Item No.	RBS020902T	Description	Tilt Sensor Switch	Version	14
Page	9 of 9		Date	Jan. 08, 2018	

● NOTES

1. Suggestion for usage : For vibration usage or application · we suggest to add hysteresis for IC; if vibration is heavy, optical type of sensor switch is recommended.
2. For the continued product improvement as one of the company policy, specifications may change or update without notice. The latest information can be obtained through our sales offices. Normally, all products are supplied under our standard conditions.
3. If buyer's products will stay in power supply for a long time which needs very high stability, optical sensor switch is strongly recommended.

● PRECAUTIONS FOR USE

1. If the products is intended to be used for other endurance equipment requiring higher safety and reliability such as life support system, space and aviation devices, disaster and safety system, it's necessary to make verification of conformity or contact us for the details before using.
2. Do not try to clean the switch with a solvent or similar substance after the soldering process.
3. Use water-soluble flux may damage the switch.
4. If soldering temperature exceeds our specification, sensor switch could get apart.
5. Do not use switch in the environment of high humidity · because such an environment may cause the leakage current between the terminals.
6. Please do not exceed the rated load as there will be a risk of disabling the product function.
7. In the circuit, switch should not be near or directly connected with the magnetic component solder joints (for example: relays, transformers, etc.).
8. Complete welding within 168 hours after unpacking, to avoid products humid which caused by prolonged exposure.

