

# PSM-ME-RS485/RS485-P

## Repeater for RS-485 2-wire bus systems



Data sheet

100273\_en\_09

© Phoenix Contact

2023-01-18

## 1 Description

The **PSM-ME-RS485/RS485-P** RS-485 repeater was developed for the high requirements of fieldbus systems. The device is snapped onto standard DIN rails in the control cabinet and supplied with 24 V DC or AC.

You can use the repeater in all common 2-wire bus systems: Modbus, RACKBUS (Endress & Hauser), SUCONET-K (Moeller), UNI-TELWAY (Telemecanique), DANBUS (Danfoss), RS-BUS (Landis & Staefa), NET 2000 (B&R), INSUM (ABB), J-BUS (Merlin Gerin), ET-WAY (Jetter), S-BUS (SAIA) and around 60 more company-specific bus systems.

Possible applications:

- Electrical isolation and bus segmentation
- Increasing system availability
- Increasing the range
- Increasing the transmission speed
- Extending the number of devices
- Creation of mixed and network structures

## Features

- Supports all popular 10/11-bit UART data formats
- Automatic transmit/receive changeover
- Transmission speed 1.2 kbps ... 1.5 Mbps
- Integrated, connectable termination resistors
- High-quality 3-way isolation between all interfaces
- Integrated surge protection with transient discharge to the DIN rail
- Supply voltage of 24 V DC or AC to suit the control cabinet
- Plug-in screw connection terminal blocks
- Shipbuilding approval in accordance with DNV GL



### **WARNING: Explosion hazard when used in potentially explosive areas**

The device is a category 3 item of electrical equipment. Follow the instructions provided here during installation and observe the safety notes.



Make sure you always use the latest documentation.

It can be downloaded at: [phoenixcontact.net/product/2744429](https://phoenixcontact.net/product/2744429)

---

<b>2</b>	<b>Table of contents</b>	
1	Description .....	1
2	Table of contents .....	2
3	Ordering data .....	3
4	Technical data .....	3
5	Safety notes.....	7
	5.1 Installation notes .....	7
	5.2 Installation in Zone 2.....	7
	5.3 UL notes.....	8
6	Transport and unpacking .....	8
7	Application examples .....	9
8	Product description.....	10
	8.1 Dimensions .....	10
	8.2 Basic circuit diagram .....	10
	8.3 Function elements .....	11
9	Configuration via DIP switches .....	12
	9.1 Transmission speed .....	12
	9.2 Termination resistor.....	12
10	Connecting data cables .....	13
11	Installation .....	14
	11.1 Mounting .....	14
	11.2 Removal.....	14
	11.3 Connecting the supply voltage .....	14
12	Disposal.....	15

### 3 Ordering data

Description	Type	Item no.	Pcs./Pkt.
Repeater, for potential separation and range increase in RS-485 2-wire bus systems, 3-way isolation, rail-mountable	PSM-ME-RS485/RS485-P	2744429	1
Accessories	Type	Item no.	Pcs./Pkt.
Shield connection clamp for terminal points starting from 2.5 mm <sup>2</sup>	ME-SAS	2853899	10
Actuation tool, for ST terminal blocks, also suitable for use as a bladed screwdriver, size: 0.6 x 3.5 x 100 mm, 2-component grip, with non-slip grip	SZF 1-0,6X3,5	1204517	10
Active termination resistor for PROFIBUS and RS-485 bus systems, redundant power supply, routing of the supply voltage via DIN rail connector, electrical isolation, switchable termination, integrated programming interface	PSI-TERMINATOR-PB-TBUS	2702636	1

### 4 Technical data

Supply	
Supply voltage range	18 V AC/DC ... 30 V AC/DC (via pluggable COMBICON screw terminal block)
Nominal supply voltage	24 V AC/DC
Typical current consumption	90 mA (24 V DC)
Max. current consumption	100 mA
Electrical isolation	VCC // RS-485 (A) // RS-485 (B)
Test voltage data interface/power supply	1.5 kV <sub>rms</sub> (50 Hz, 1 min.)
Tightening torque	0.56 Nm ... 0.79 Nm
Conductor cross section	
	flexible 0.20 mm <sup>2</sup> ... 2.50 mm <sup>2</sup>
	AWG flexible 24 AWG ... 12 AWG
	rigid 0.20 mm <sup>2</sup> ... 2.50 mm <sup>2</sup>

<b>RS-485 interface, in acc. with EIA/TIA-485, DIN 66259-4/RS-485 2-wire</b>	
Transmission channels	2 (1/1), TD, RD, half duplex
Operating mode	Semi-duplex
Connection method	Pluggable screw connection
Conductor cross section	
	flexible 0.2 mm <sup>2</sup> ... 2.5 mm <sup>2</sup>
	flexible AWG 24 AWG ... 12 AWG
Data format/encoding	UART (11/10 bit switchable; NRZ)
Data direction switching	Automatic control, min. station response time 1 bits
Termination resistor	390 Ω / 180 Ω / 390 Ω
Serial transmission speed	1.2 / 2.4 / 4.8 / 9.6 / 19.2 / 38.4 / 57.6 / 75 / 93.75 / 115.2 / 136 / 187.5 / 375 / 500 / 1500 kbps
Transmission length	≤ 1200 m (depends on transmission speed, bus system and cable type)
Transmission medium	2-wire twisted pair, shielded
Protocols supported	transparent protocol
<b>General data</b>	
Degree of protection	IP20
Pollution degree	2
Dimensions (W/H/D)	22.5 mm x 99 mm x 114.5 mm
Material	
	Housing PA 6.6-FR
Color	
	Housing green (6021)
Free fall in acc. with IEC 60068-2-32	1 m
Vibration resistance in acc. with EN 60068-2-6/ IEC 60068-2-6	5g, 10...150 Hz, 2.5 h, in XYZ direction
Shock in acc. with EN 60068-2-27/IEC 60068-2-27	25g, 11 ms period, half-sine shock pulse
Bit distortion, input	max. ± 35 %
Bit distortion, output	< 3.6 %
Bit distortion	< 1.5 %
Bit delay	< 200 ns
Noise emission according to	EN 61000-6-4
Noise immunity according to	EN 61000-6-2:2005
Electromagnetic compatibility	Conformance with EMC Directive 2014/30/EU
Transmission channels	2 (1/1), TD, RD, half duplex
<b>MTTF (mean time to failure)</b>	
SN 29500 standard, temperature 25°C, operating cycle 21%	1808 Years
SN 29500 standard, temperature 40°C, operating cycle 34.25%	796 Years
SN 29500 standard, temperature 40°C, operating cycle 100%	334 Years

<b>Ambient conditions</b>	
Ambient temperature	
	Operation -40 °C ... 70 °C
	Storage/transport -40 °C ... 85 °C
Humidity	
	Operation 10 % ... 95 % (non-condensing)
Altitude	≤ 5000 m (For restrictions, see the manufacturer's declaration for altitude operation)
<b>Conformance/Approvals</b>	
CE	CE-compliant
EAC	EAC
ATEX	Ⓢ II 3 G Ex nA IIC T4 Gc IExU16ATEXB004 X Please follow the special installation instructions in the documentation!
IECEX	Ex nA IIC T4 Gc IECEX IBE 15.0034X
UL, USA / Canada	508 Recognized Class I, Div. 2, Groups A, B, C, D Class I, Zone 2, AEx nA IIC T4 Class I, Zone 2, Ex nA IIC T4 Gc X
KC approval for South Korea	KCC-REI-PCK-FL2744429
Corrosive gas test	ISA-S71.04-1985 G3 Harsh Group A
Shipbuilding	DNV GL
	Temperature B
	Humidity A
	Vibration A
	EMC B
	Enclosure Required protection according to the Rules shall be provided upon installation on board

**Conformance with EMC Directive 2014/30/EU****Immunity in accordance with EN 61000-6-2**

Electrostatic discharge	EN 61000-4-2	
	Contact discharge	$\pm 6$ kV (Test Level 3)
	Discharge in air	$\pm 8$ kV (Test Level 3)
	Indirect discharge	$\pm 6$ kV (Test Level 3)
	Comments	Criterion B
Electromagnetic HF field	EN 61000-4-3	
	Frequency range	26 MHz ... 3 GHz (Test Level 3)
	Field intensity	10 V/m
	Comments	Criterion A
Fast transients (burst)	EN 61000-4-4	
	Input	$\pm 4$ kV (Test Level 3)
	Signal	$\pm 2$ kV (Test Level 3)
	Comments	Criterion B
Surge current loads (surge)	EN 61000-4-5	
	Input	$\pm 0.5$ kV (DC supply)
	Signal	$\pm 2$ kV (Data line, asymmetrical)
	Comments	Criterion B
Conducted interference	EN 61000-4-6	
	Frequency range	0.15 MHz ... 80 MHz
	Voltage	10 V
	Comments	Criterion A

Criterion A Normal operating behavior within the specified limits.

Criterion B Temporary impairment to operational behavior that is corrected by the device itself.

**Emitted interference in acc. with EN 61000-6-4**

Interference emission	EN 55011
	Class A, industrial applications

## 5 Safety notes

### 5.1 Installation notes

**WARNING:**

Observe the following safety notes when using the device.

- The category 3 device is designed for installation in zone 2 potentially explosive areas. It meets the requirements of EN 60079-0:2012+A11:2013 and EN 60079-15:2010.
- Installation, operation, and maintenance may only be carried out by qualified electricians. Follow the installation instructions as described.
- When installing and operating the device, observe the applicable regulations and safety directives (including national safety directives), as well as the generally recognized technical regulations. The safety data is provided in the packing slip and on the certificates (conformity assessment, additional approvals where applicable).
- Changing or modifying the device beyond the configuration is not permitted. Do not repair the device yourself; replace it with an equivalent device. Repairs may only be performed by the manufacturer. The manufacturer is not liable for damage resulting from noncompliance.
- The IP20 degree of protection (IEC/EN 60529) specifies that the device is intended for use in a clean and dry environment. Do not subject the device to mechanical and/or thermal stress that exceeds the specified limits.
- The device is designed exclusively for operation with SELV/PELV from a Class ES1 "electrical energy source" in accordance with EN/IEC 62368-1 and VDE 0868-1. The device may only be connected to devices that meet the requirements of class ES1 in accordance with EN/IEC 62368-1.

### 5.2 Installation in Zone 2

**WARNING: Explosion hazard when used in potentially explosive areas**

Please make sure that the following notes and instructions are observed.

- Use in potentially explosive areas is not permitted in China.
- Observe the specified conditions for use in potentially explosive areas.
- The devices must be installed in a housing which is designed in a type of protection in accordance with EN 60079-0, section 1 and has a minimum protection rating of IP54.
- In zone 2, only connect devices to the supply and signal circuits that are suitable for operation in the Ex zone 2 and the conditions at the installation location.
- The switches of the device that can be accessed may only be actuated when the power supply to the device is disconnected.
- The device must be stopped and immediately removed from the Ex area if it is damaged, was subject to an impermissible load, stored incorrectly or if it malfunctions.
- In potentially explosive areas, terminals may only be snapped onto or off the DIN rail connector and wires may only be connected or disconnected when the power is switched off.
- The device is not designed for use in atmospheres with a danger of dust explosions.

### 5.3 UL notes

**WARNING: Explosion hazard when used in potentially explosive areas**

Please make sure that the following notes and instructions are observed.

**PROCESS CONTROL EQUIPMENT FOR HAZARDOUS LOCATIONS 31ZN**

- A) All wiring of these devices must be in accordance with the national electric code article 501.4(B) for Class 1, Division 2.
- B) Product must be installed in Class I, Zone 2 certified at least an IP54 enclosure.
- C) Product must be used in no more than a pollution degree 2 environment as defined by IEC 60664-1
- D) Provisions must be made to provide transient protection to the product so that voltage levels do not exceed 40% of the rated voltage at the power supply terminals.

Wire Range: 30-12 AWG,

Torque: 5-7 Lbs-Ins

Supply voltage range 24 V DC  $\pm 20\%$   $\leq 90$  mA

## 6 Transport and unpacking

- Check the delivery for visible damage caused by transportation.
- Submit claims for any transport damage immediately. Inform Phoenix Contact or your supplier as well as the shipping company without delay.
- Read the complete packing slip carefully.
- Retain the packing slip.
- Keep the packaging for a possible later transport.



## 7 Application examples

The repeater can be used to create network structures that are tailored to the relevant application.

The limits set by the RS-485 standard are therefore extended. The standard defines the following basic specifications:

- Up to 32 devices per potential segment
- Only line structures
- Maximum bus cable length: 1200 m
- Maximum branch line length without termination resistor: 5 m, depending on the transmission speed
- Bus cable termination at the start and end of the bus cable



Please note that in each potential segment, the port of the repeater must be considered as a device.

The bus and spur line lengths depend on the transmission speed and cable type. For specifications, refer to the manufacturer's manual for the bus system used.

Figure 1 Cable lengths according to the RS-485 standard

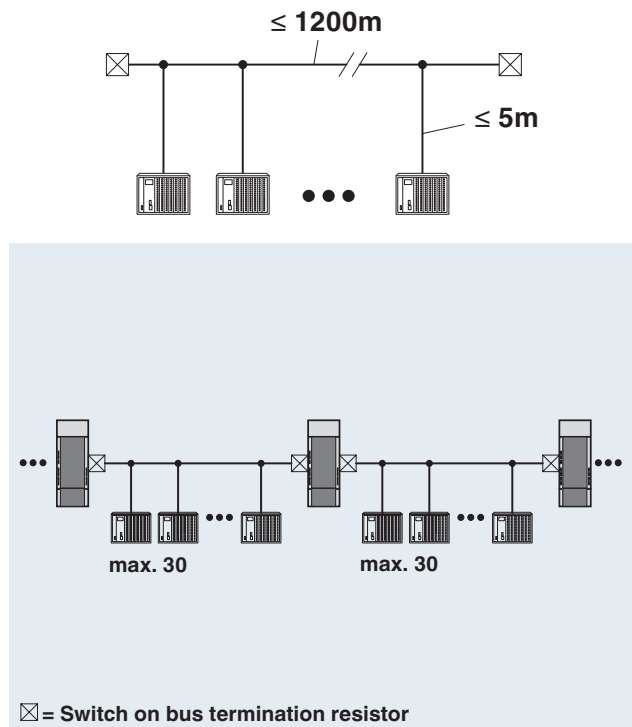

## 8 Product description

### 8.1 Dimensions

Figure 2 Housing dimensions

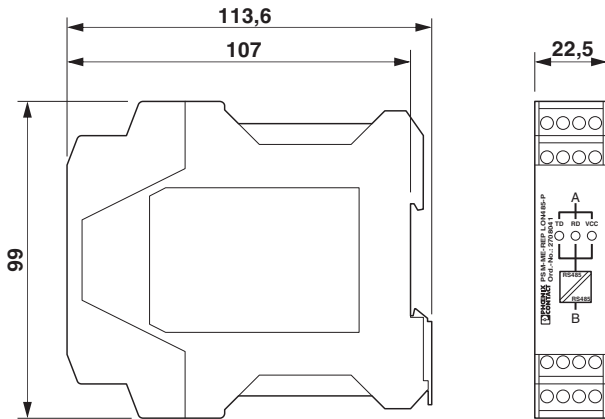

### 8.2 Basic circuit diagram

Figure 3 Basic circuit diagram

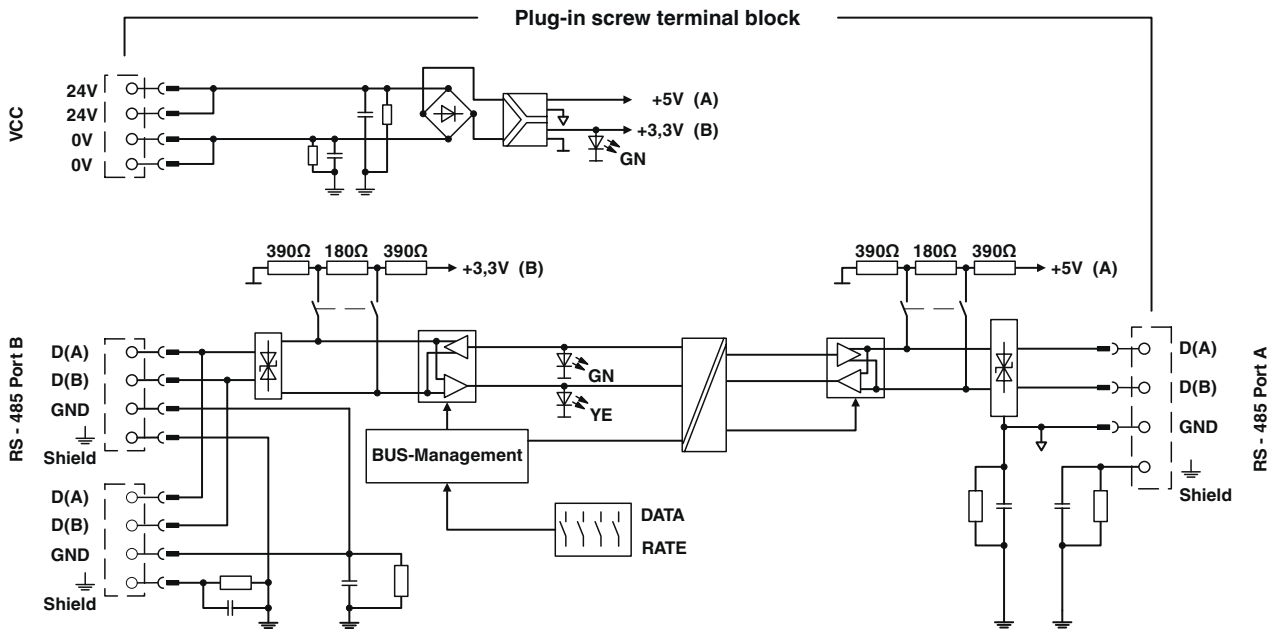

### 8.3 Function elements

Figure 4 Function elements

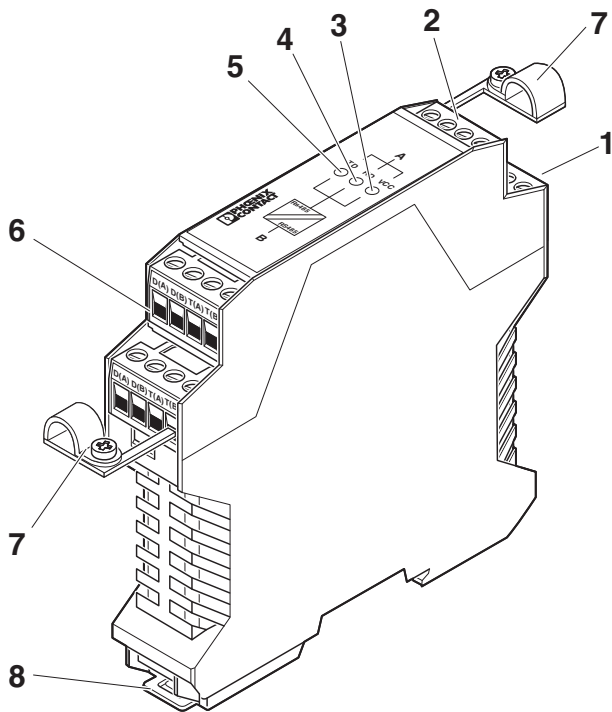

#### COMBICON plug-in screw terminal blocks

- 1 Power supply (pin 1 + pin 3)
- 2 RS-485 interface, port A
- 6 RS-485 interface, port B

#### Diagnostics and status indicators

- 3 VCC (green) Supply voltage
- 4 RD (green) RS-485 (A) Data received
- 5 TD (yellow) RS-485 (A) Data transmission

#### Operating elements

- 7 Shield connection clamp
- 8 Locking latch for DIN rail mounting

## 9 Configuration via DIP switches

You must open the housing to access the DIP switches and slide switches.



**NOTE: electrostatic discharge!**

Electrostatic discharge can damage or destroy components.

- When handling the device, observe the necessary safety precautions against electrostatic discharge (ESD) in accordance with EN 61340-5-1 and IEC 61340-5-1.

- Disengage the housing cover with a screwdriver (A).
- Carefully pull the PCB out of the housing as far as possible.

Figure 5 Opening the housing

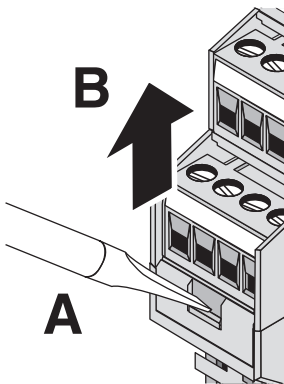
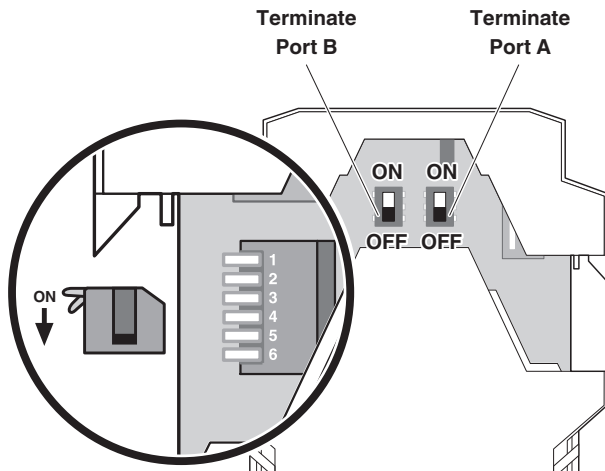

Figure 6 Remove the PCB



### 9.1 Transmission speed

- Set the transmission speed using the DIP switches.

	ON $\hat{=}$ <input checked="" type="checkbox"/>	DIP					
		1	2	3	4	5	6
Speed	1500						
kbps	500				•		
	375			•			
	187.5			•	•		
	136		•				
	115.2		•		•		
	93.75		•	•			
	75		•	•	•		
	57.6	•					
	38.4	•				•	
	19.2	•		•			
	9.6	•		•	•		
	4.8	•	•				
	2.4	•	•			•	
	1.2	•	•	•			

\* Transmission speeds of 1.2 kbps and 2.4 kbps are available as of hardware/firmware (HW/FW) Version 20/300.



Set all PSM repeaters and bus devices to the same data speed.

### 9.2 Termination resistor

To terminate the RS-485 bus line, the device incorporates a connectable termination resistor for each port.

- Activate the termination resistor by setting the TERMINATE slide switch to ON.



Terminate the RS-485 bus line at the two furthest ends of the bus.

## 10 Connecting data cables



### NOTE: Interference

Use shielded twisted pair data cables. Connect the cable shielding at both ends of the transmission path.

Figure 7 RS-485 interface

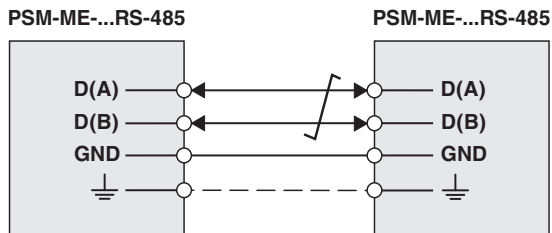

- To couple two RS-485 interfaces, connect them with a twisted lead pair.

D(A) = Data line -  
D(B) = Data line +

Figure 8 Install shield connection clamp

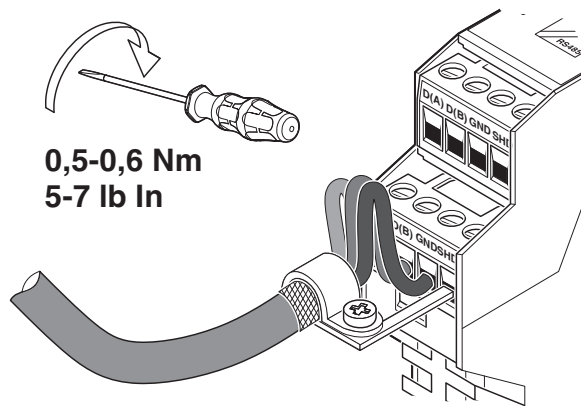

- For the shield connection, use the provided shield connection clamp.

## 11 Installation



### CAUTION: Electric shock

The device is designed exclusively for operation with SELV/PELV from a Class ES1 “electrical energy source” in accordance with EN/IEC 62368-1 and VDE 0868-1.



### NOTE: Malfunction

Connect the DIN rail to protective earth ground using a grounding terminal block. The device is grounded when it is snapped onto the DIN rail.

This ensures the integrated surge protection is functional and that the shielding of the data cable is effective.

### 11.1 Mounting

Figure 9 Mounting on a DIN rail

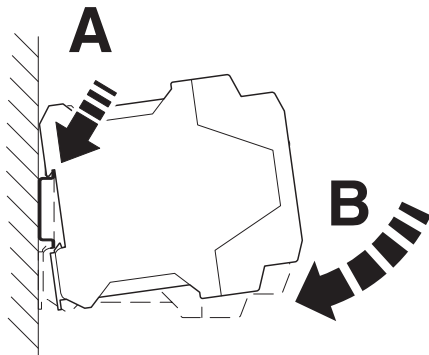

- To avoid contact resistance, only use clean, corrosion-free 35 mm DIN rails according to DIN EN 60715.
- Install an end bracket next to the left-hand device to prevent the devices from slipping.
- Place the device onto the DIN rail from above. Push the device from the front toward the mounting surface until it audibly engages.

### 11.2 Removal

Figure 10 Removal

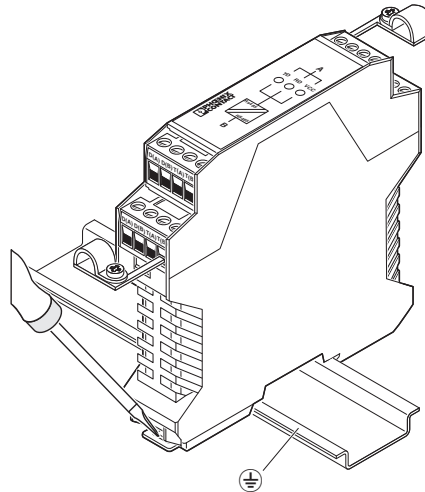

- Push down the locking tab with a screwdriver, needle-nose pliers or similar.
- Slightly pull the bottom edge of the device away from the mounting surface.
- Pull the device away from the DIN rail.

### 11.3 Connecting the supply voltage

The device is supplied with 24 V DC or AC.

Figure 11 Connecting the supply voltage

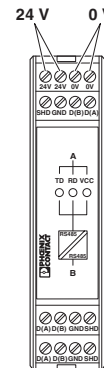

- Provide supply voltage to the device via terminal 1 (pin 1 and pin 3).

## 12 Disposal



The symbol with the crossed-out trash can indicates that this item must be collected and disposed of separately. Phoenix Contact or our service partners will take the item back for free disposal. For information on the available disposal options, visit [www.phoenixcontact.com](http://www.phoenixcontact.com).