

ALTW
CONFIDENTIAL
 2015-09-28
 R&D DEPT.

REV.	ECN NO.	DATE	SIGN	DESCRIPTION

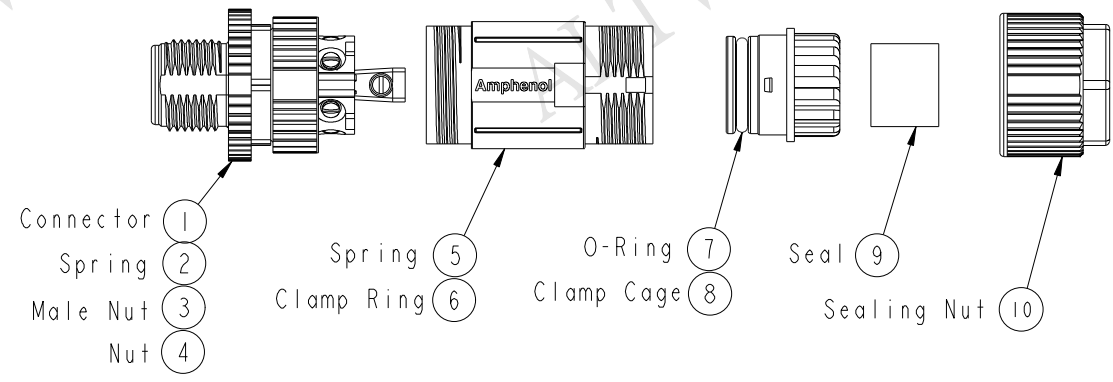

ALTW
 DCC. DEPT.
 CONFIDENTIAL
 2015.10.28
 ISSUED

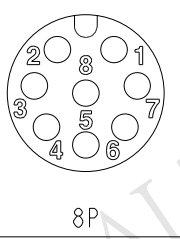
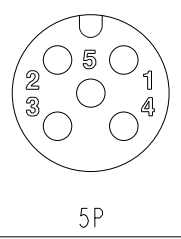
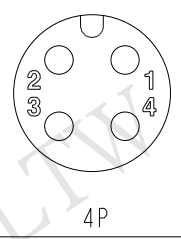
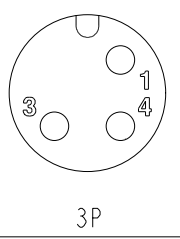
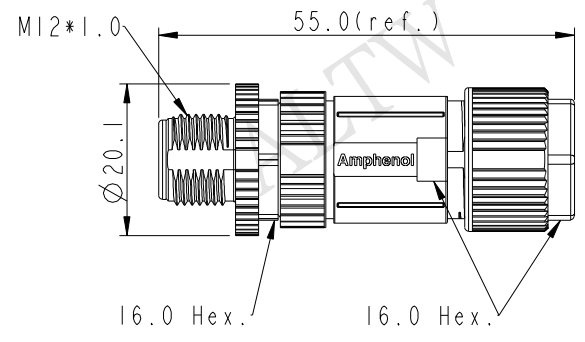

Pin Assignments Front View

UNIT:mm
 TOLERANCE
 ±0.5mm

TITLE M12 A-code Shielded Assy M Conn. M Pin			
SCALE 1:1	SIZE A4	SHEET 1 OF 2	
REV. A	WC-REV. A.5	QC: Inspection item	

Amphenol LTW
 安費諾亮泰企業股份有限公司

ITEM NO.	DRAWN BY Mila	DATE 2015-09-28
DWG NO. MSAS-XXBMMB-SL7001	CHECKED BY Cary	DATE 2015-09-28
CUSTOMER ALTW	APPROVED BY Jerry	DATE 2015-09-28

THIS DOCUMENT IS SUBJECT TO CHANGE WITHOUT NOTICE. IT IS CONFIDENTIAL AND A PROPERTY OF AMPHENOL LTW. DISCLOSURE TO THIRD PARTY HAS TO BE AUTHORIZED BY AMPHENOL LTW.

M SAS - XX B M M B - S L 7 001

SAS: A-Code Shielded

03: 3Pin
04: 4Pin
05: 5Pin
08: 8Pin

B: Without S/R(無網尾)

M: Male Connector(公座)

M: Male Pin(公Pin)

001: Without Cable

7: IP67(防水等級67)

L: Straight(180°)

S: Screw(螺紋式)

B: Screw in Type(組裝式)

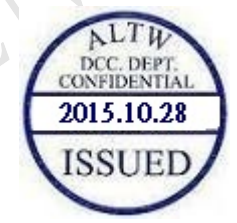
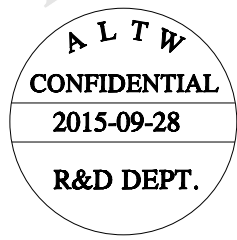

Note:

- * \varnothing Important Dimension To Check.
- * Waterproof Rate: IP67
- * Housing: Nylon, Black
- * Clamp Cage: Nylon, Black
- * Male Pin: Copper Alloy, Gold Plated
- * Male Nut: Zinc Alloy, Nickel Plated
- * Nut: Zinc Alloy, Nickel Plated
- * O-Ring: Silicon, Grey
- * Clamp Ring: Zinc Alloy, Nickel Plated
- * Sealing Nut: Zinc Alloy, Nickel Plated
- * Seal: Silicon, Grey
- * Seal For Cable OD: $\varnothing 4.0\text{mm} \sim \varnothing 7.5\text{mm}$
- * Screws for Wire connection recommended
tightening torque: 0.61~0.84 kgf.cm / 0.059~0.082 N.m
- * Applicable Wire gauge (Stranded wire cross section)
0.14mm² (26AWG) ~ 0.82mm² (18AWG)
- * Mating Recommended tightening torque:
3~4 kgf.cm / 0.29~0.39 N.m
- * Sealing-Nut Recommended tightening torque:
4~6 kgf.cm / 0.39~0.59 N.m
- * Detailed applicable wire specifications may vary depending on the actual wire construction.

UNIT: mm		TITLE		ITEM NO		DRAWN BY		DATE	
		M12 A-code Shielded Assy M Conn. M Pin		MSAS-XXBMMB-SL7001		Mila		2015-09-28	
		SCALE	SIZE	SHEET	OF	CHECKED BY	DATE		
TOLERANCE		1:1	A4	2	2	Cary	2015-09-28		
±0.5mm		REV.	WC-REV.	QC: Inspection item		APPROVED BY		DATE	
		A	A.5			Jerry		2015-09-28	
				CUSTOMER		ALTW			

Amphenol LTW
安費諾亮泰企業股份有限公司