

THIS COPY IS PROVIDED ON A RESTRICTED BASIS AND IS NOT TO BE USED IN ANY WAY DETRIMENTAL TO THE INTERESTS OF PANCON.

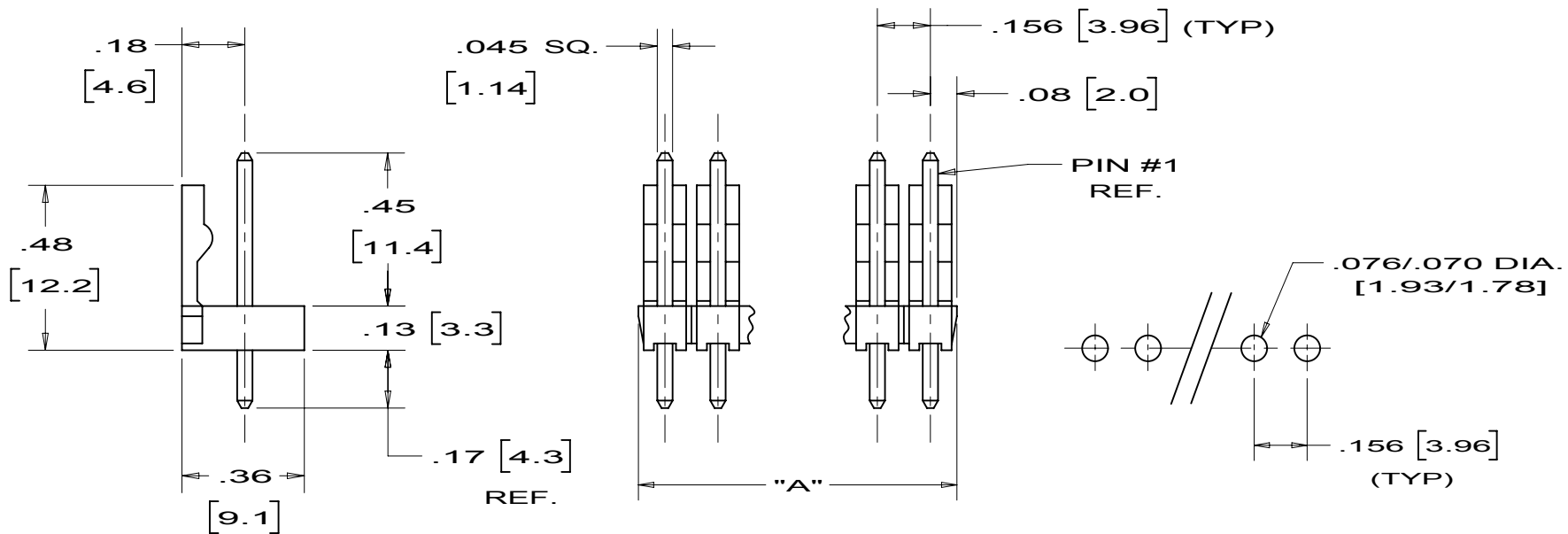

RECOMMENDED P.C. BOARD LAYOUT

NOTES:

- * 1. SEE CURRENT PRICE SHEET FOR PART NUMBER SUFFIX DESIGNATION FOR PACKAGE SIZE
- 2. POST MATERIAL: BRASS ALLOY; BRIGHT ACID TIN OVER NICKEL PLATING
- 3. WAFER MATERIAL: THERMOPLASTIC, U.L. 94V-0
- 4. ALL DIMENSIONS ARE SHOWN IN INCHES AND [MILLIMETERS]
- 5. FOR 15 MICRINCH GOLD OVER NICKEL OR GOLD FLASH OVER PALLADIUM NICKEL, ADD THE "B" SUFFIX TO THE PART NUMBER

U.L. RECOGNIZED FILE #E73711

CAD NO. KA-10056, LAYER 1



Bolingbrook, Illinois

MAS-CON[®], .156" LOCKING HEADER WITH SQUARE STRAIGHT PINS

UNLESS OTHERWISE SPECIFIED, DIMENSIONAL TOLERANCES ARE:
 (.X) ± (.XXX) ± .005(.13)
 (.XX) ± .02(ANGLES) ±

UNLESS OTHERWISE SPECIFIED, ALL DIMENSIONS ARE GIVEN IN INCHES.
 THIRD ANGLE PROJECTION.
 SCALE

DRAWN BY
JEP

DATE
4-7-88

CHK'D
WJH

MAT'L
SEE NOTES

DRAWING NO.
KA-10056

SHT 1 OF 2

SCALE
2:1
 DWG. SIZE
A

REV	DATE	BY	CHK	DESCRIPTION	CN - R	CUST	SUP
6	6/28/10	SHC		ADDED PDNI PLATING ALTERNATIVE			

THIS COPY IS PROVIDED ON A RESTRICTED BASIS AND IS NOT TO BE USED IN ANY WAY DETRIMENTAL TO THE INTERESTS OF PANCON.

* PART NO.	# OF CKTS	DIM. A IN. (MM)	WT./ 100 PCS LBS. (GRAMS)
MLSS156-2	2	.31 (7.9)	.16 (72)
MLSS156-3	3	.47 (11.9)	.24 (109)
MLSS156-4	4	.62 (15.8)	.32 (145)
MLSS156-5	5	.78 (19.8)	.40 (181)
MLSS156-6	6	.94 (23.8)	.48 (217)
MLSS156-7	7	1.09 (27.7)	.56 (254)
MLSS156-8	8	1.25 (31.7)	.64 (291)
MLSS156-9	9	1.40 (35.7)	.72 (327)
MLSS156-10	10	1.56 (39.6)	.80 (363)
MLSS156-11	11	1.72 (43.6)	.88 (400)
MLSS156-12	12	1.87 (47.5)	.96 (436)

* PART NO.	# OF CKTS	DIM. A IN. (MM)	WT./ 100 PCS LBS. (GRAMS)
MLSS156-13	13	2.03 (51.5)	1.04 (472)
MLSS156-14	14	2.18 (55.5)	1.12 (509)
MLSS156-15	15	2.34 (59.4)	1.20 (545)
MLSS156-16	16	2.50 (63.4)	1.28 (582)
MLSS156-17	17	2.65 (67.4)	1.36 (618)
MLSS156-18	18	2.81 (71.3)	1.44 (654)
MLSS156-19	19	2.96 (75.3)	1.52 (691)
MLSS156-20	20	3.12 (79.2)	1.60 (727)
MLSS156-21	21	3.28 (83.2)	1.68 (763)
MLSS156-22	22	3.43 (87.2)	1.76 (800)
MLSS156-23	23	3.59 (91.1)	1.84 (836)
MLSS156-24	24	3.74 (95.1)	1.92 (872)

*SEE NOTE #1

U.L. RECOGNIZED FILE #E73711



										 www.pancon.de / GERMANY www.panconconnectors.com / USA		Bolingbrook, Illinois		
										MAS-CON[®], .156" LOCKING HEADER WITH SQUARE STRAIGHT PINS				
										UNLESS OTHERWISE SPECIFIED, DIMENSIONAL TOLERANCES ARE: (.X) ± (.XXX) ± .005(.13) (.XX) ± .02(AN) ANGLES ±		UNLESS OTHERWISE SPECIFIED, ALL DIMENSIONS ARE GIVEN IN INCHES. THIRD ANGLE PROJECTION. SCALE 2:1		
										DRAWN BY JEP		SEE NOTES		
										DATE 4-7-88				
										CHK'D WJH		DRAWING NO. KA-10056		
												SHT 2 OF 2		
6				ADDED PDNI PLATING ALTERNATIVE								A SIZE		
REV	DATE	BY	CHK	DESCRIPTION						CN - R	CUST	SUP		