

**SECTION A-A
SIDE VIEW**

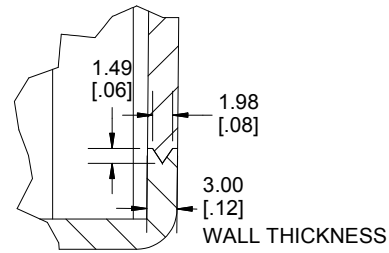

**DETAIL D
GROOVE**

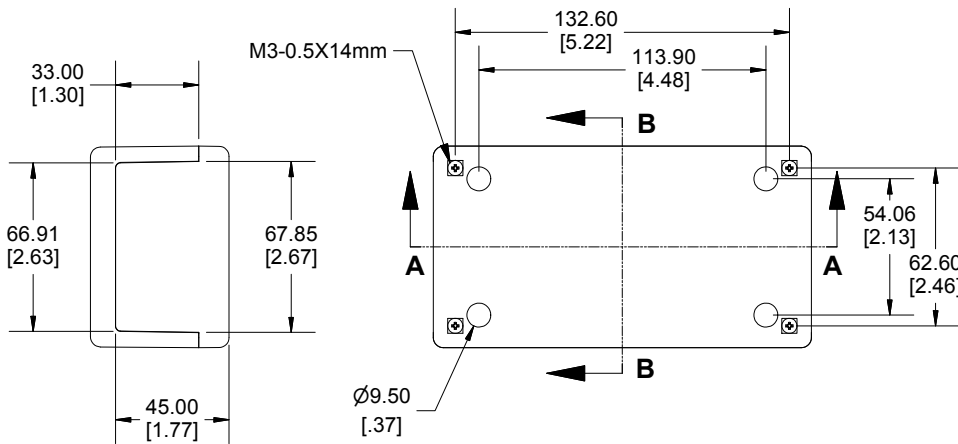
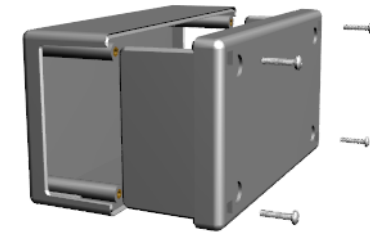

**SECTION B-B
END VIEW**

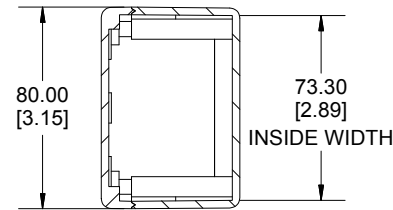

INSIDE WIDTH

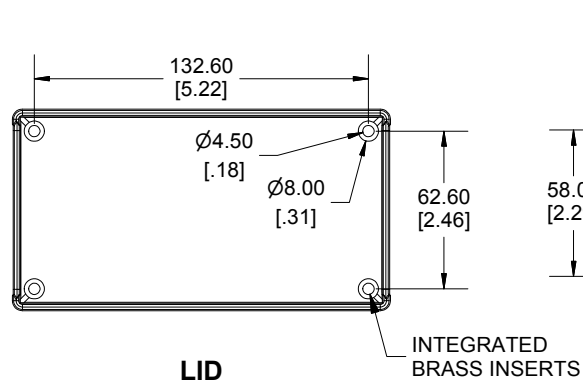

LID

INTEGRATED
BRASS INSERTS

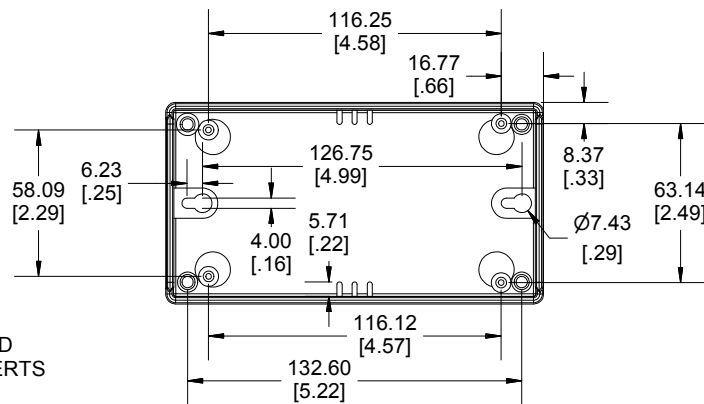

BOX

Dimensions:
mm
[inches]

Enclosures can be Factory Modified (Milling, Drilling, Printing etc.)
Contact Factory mjm@hammondmfg.com for quotes
Solid models of this enclosure available in STEP or IGES.

NOTE

Purchased assembly includes box, lid, 4 cover screws,
and 4 P.C. board screws.

Recommended Cover Screw Torque -- 2.5 lbf-in (30 cN-m)

MB1580	
MB1580 Regular Enclosure	
Lid smooth light gray (RAL 7035)	MB158055
Bottom smooth dark gray (RAL 7012)	

**HAMMOND
MANUFACTURING™**

MB158055

www.hammondmfg.com