

	DATE	10-11-2022	SPECIFICATION	ChangZhou Cre-Sound Cre-Sound Electronics Co.,Ltd.
	PAGE	1/5		www.cre-soundbuzzer.com
	Rev.	A/0		www.wj-Lianhua.com
<i>MODEL NAME: LPT3308AZ-GB-24-3.25-120-R</i>				

SPECIFICATION FOR APPROVAL PIEZO TRANSDUCER

Model Name	LPT3308AZ-GB-24-3.25-120-R
Note	

Product Photo	Cre-Sound
	DRAWING: 姚宝鑫
	CHECKED: 韦 娟
	APPROVED: 宋雪琪
Customer Confirmation:	

ChangZhou Cre-Sound Electronics Co.,Ltd.
Tel: +86-519-86321175; Fax: +86-519-86702455
E-mail: martin@wj-lianhua.com

	DATE	10-11-2022	SPECIFICATION	ChangZhou Cre-Sound Cre-Sound Electronics Co.,Ltd.
	PAGE	3/5		www.cre-soundbuzzer.com
	Rev.	A/0		www.wj-Lianhua.com
MODEL NAME: LPT3308AZ-GB-24-3.25-120-R				

Technical Terms:

No.	Technical terms	Value
1	Rated Voltage (Vp-p)	24
2	Max Input Voltage (Vp-p)	50
3	*Rated Current(mA)	≤80
4	Capacitance at 120Hz (nF)	120 ± 30%
5	*Sound Output at 3 m(dB)	≥90
6	Resonance Frequency (Hz)	3250 ± 500
7	Operating Temperature(°C)	-20~+60
8	Storage Temperature(°C)	-30~+70
9	Weight (g)	3.5
10	Housing Material	PBT
11	RoHS	Yes

*Applying rated voltage (at 3250Hz, 1/2 duty , square wave)

Test Basic State: Temp(20 ± 2°C), Humidity(40~70%RH), Air pressure(860~1060hPa).

Dimensions (UNIT: mm):

Tolerance: ±0.5mm Except Specified

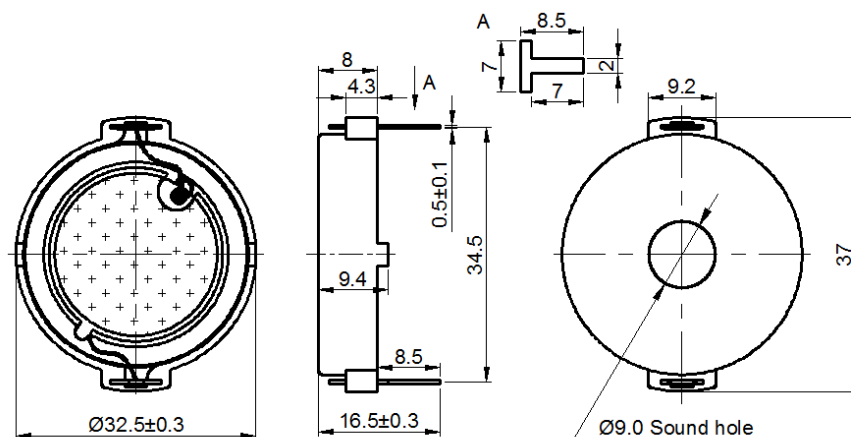

ChangZhou Cre-Sound Electronics Co.,Ltd.

Tel: +86-519-86321175; Fax: +86-519-86702455

E-mail: martin@wj-lianhua.com

	DATE	10-11-2022	SPECIFICATION	ChangZhou Cre-Sound Cre-Sound Electronics Co.,Ltd.
	PAGE	4/5		www.cre-soundbuzzer.com
	Rev.	A/0		www.wj-Lianhua.com
MODEL NAME: LPT3308AZ-GB-24-3.25-120-R				

Test Method:

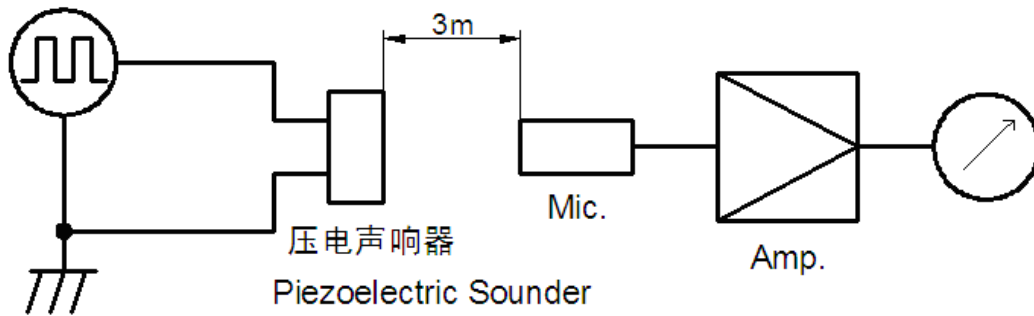

MIC: ND10 普通声级计或等同品
MIC: ND10 Sound Meter or equivalent

信号发生器: DF1641D或等同品
Signal Generator: DF1641D or equivalent

Frequency Response:

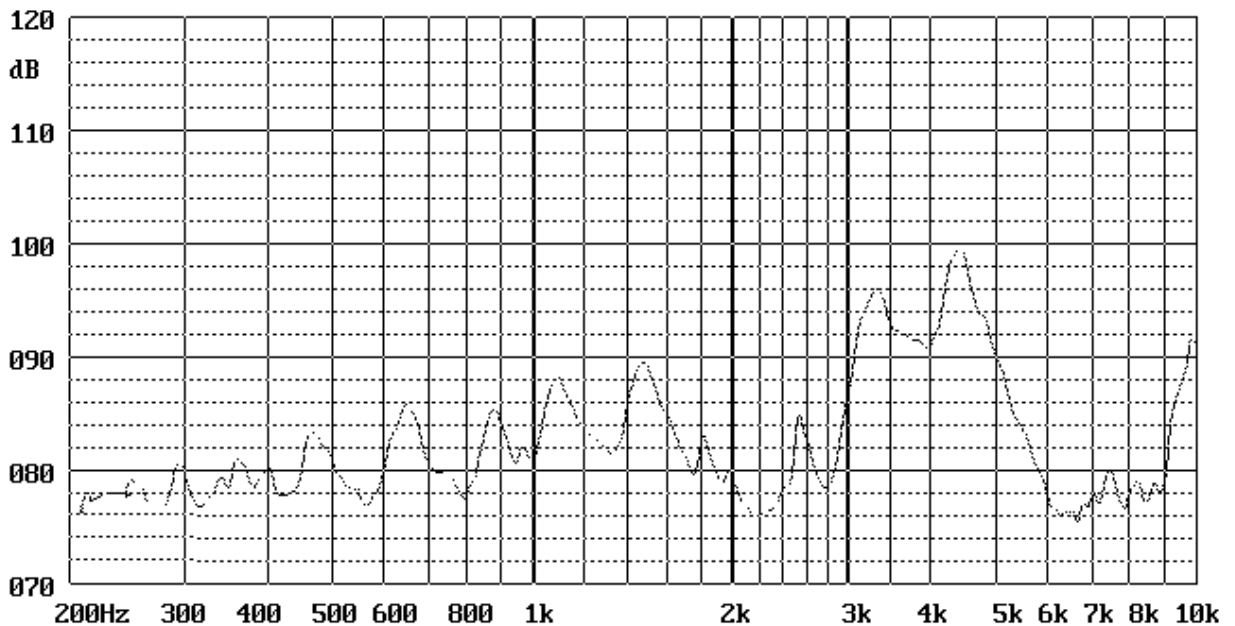

ChangZhou Cre-Sound Electronics Co.,Ltd.
Tel: +86-519-86321175; Fax: +86-519-86702455
E-mail: martin@wj-lianhua.com

	DATE	10-11-2022	SPECIFICATION	ChangZhou Cre-Sound Cre-Sound Electronics Co.,Ltd.
	PAGE	5/5		www.cre-soundbuzzer.com
	Rev.	A/0		www.wj-Lianhua.com
	<i>MODEL NAME: LPT3308AZ-GB-24-3.25-120-R</i>			

Reliability Test:

● Environment Test:

No.	Item	Test condition	Evaluation standard
1	High temp. test	+70±2°C, 96Hrs	After being placed for 2 to 4hrs at room temp, the product shall meet specifications, except the SPL should be in ±10dB compared with initial one.
2	Low temp. test	-30±2°C, 96Hrs	
3	Humidity test	40±2°C ,93(+2/-3)%RH for 96Hrs	
4	Temp. cycle test	-30±2°C, 30minutes +20±2°C, 15 minutes +70±2°C, 30 minutes +20±2°C, 15 minutes 5 cycles	

● Mechanical Characteristics:

No.	Item	Test condition	Evaluation standard
1	Solder ability	Pin terminals are immersed in rosin for 5 seconds and then immersed in solder bath of 270±5°C for 3±1s.	90% min. lead terminals shall be wet with solder.(Except the edge of terminal)
2	Soldering heat resistance	Pin terminals are immersed up to 1.5mm from part's body in solder bath of 260±5°C for 10±1s.Refer to GB2423.28.	No interference in operation
3	Vibration	1.5 mm with 10 to 55Hz band of vibration frequency to each of 3 perpendicular directions for 2 hrs.	The SPL should meet specification.
4	Drop test	The part only shall be dropped from the height of 70cm onto 10mm thick wooden board each 3 times in 3 axial directions(x,y&z) (a total of 9 times).	After the test part shall meet specifications, except the SPL should be in ±10dB compared with initial one.

ChangZhou Cre-Sound Electronics Co.,Ltd.
Tel: +86-519-86321175; Fax: +86-519-86702455
E-mail:martin@wj-lianhua.com

	DATE	10-11-2022	SPECIFICATION	ChangZhou Cre-Sound Cre-Sound Electronics Co.,Ltd.
	PAGE	5/5		www.cre-soundbuzzer.com
	Rev.	A/0		www.wj-Lianhua.com
<i>MODEL NAME: LPT3308AZ-GB-24-3.25-120-R</i>				

Packing:

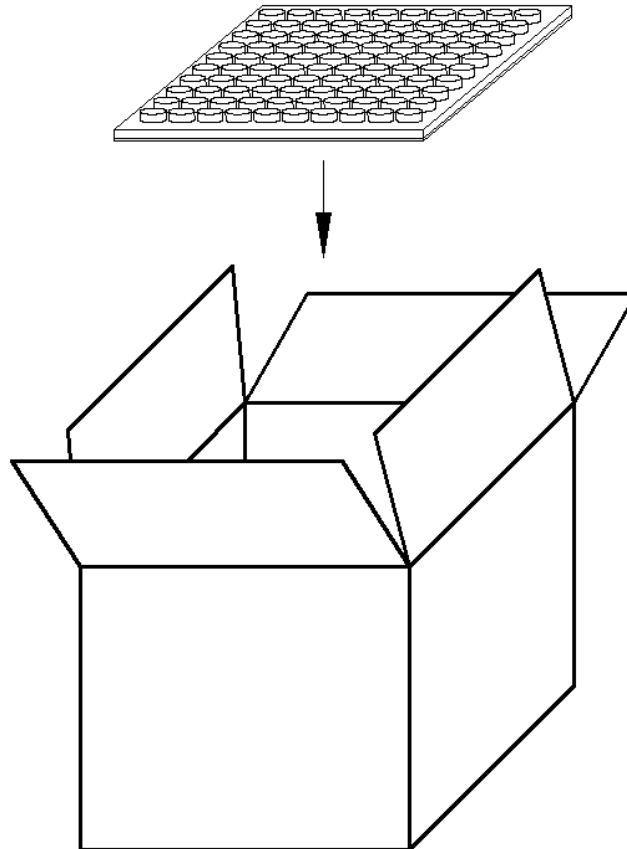

NOTES:

- 1.100 PCS per layer
- 2.Total 20 layers per carton
- 3.Total 2000 PCS carton
- 4.Volum:37.5*37.5*42.5cm

ChangZhou Cre-Sound Electronics Co.,Ltd.
Tel: +86-519-86321175; Fax: +86-519-86702455
E-mail:martin@wj-lianhua.com