



SPL (HONG KONG) LIMITED

香港九龍觀塘鴻圖道57號南洋廣場17樓1703B室
Room 1703B, 17/F., Nanyang Plaza, No.57 Hung To Road, Kwun Tong, Kowloon, HK.
Tel: 852-2342 6857 / 2342 6867 Fax: 852-2342 6847 Email: sales@spl-hk.com.hk
Website: www.buzzer.com.hk

Magnetic Buzzer

SMB07 series

DIMENSIONS

Date : 20 Oct.,2023

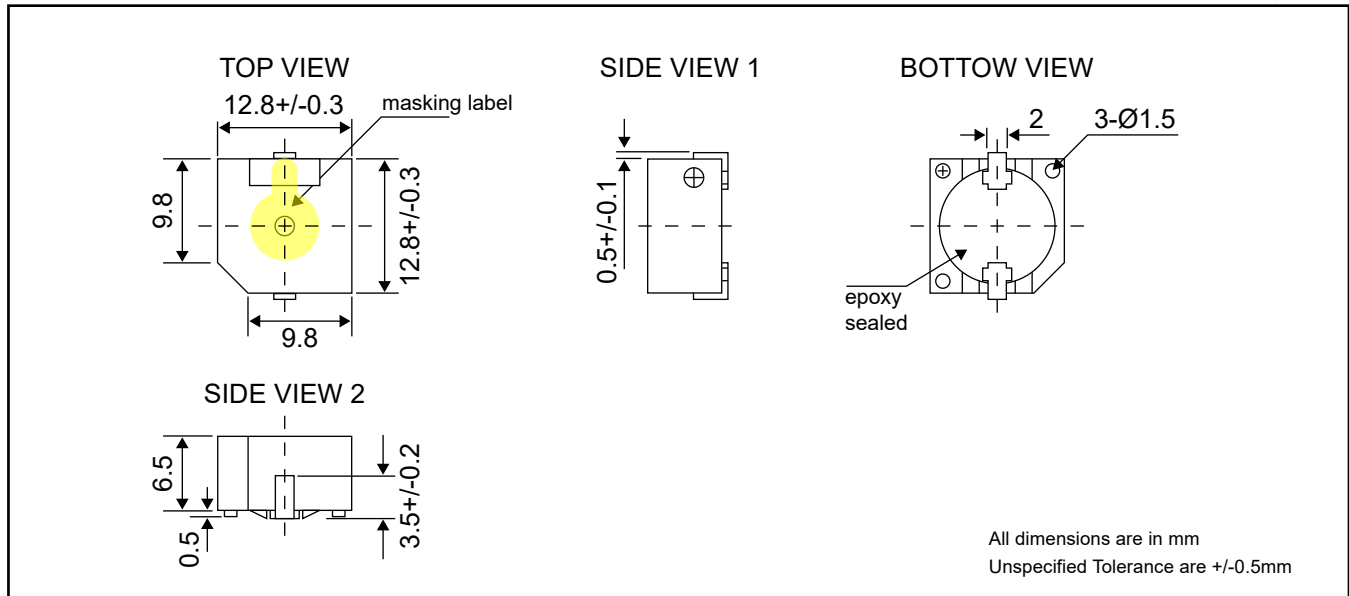

Ref No. : PBCJ2002A



ELECTRICAL SPECIFICATIONS

| | | |
|-----------------------|-----------------|---|
| Model No. | | MB07-A3PSYR |
| Operating Voltage | [VDC] | 2 ~ 5 |
| Rated Voltage | [VDC] | 3 |
| * Max. Rated Current | [mA] | 30 |
| * Min. Sound Output | [dBA / 10cm] | 80 |
| * Frequency | [Hz] | 2400 \pm 400 |
| Tone Nature | | Single |
| Heat Test | | Must Be Normal [85 \pm 3 $^{\circ}$ C, 24 Hours] |
| Cold Test | | Must Be Normal [-40 \pm 3 $^{\circ}$ C, 24 Hours] |
| Humidity Test | | 40 \pm 3 $^{\circ}$ C, 92 ~ 95% R.H. 24 Hours |
| Operating Temperature | [$^{\circ}$ C] | -30 ~ +70 [without label] |
| Storage Temperature | [$^{\circ}$ C] | -40 ~ +85 [without label] |
| Terminal | | SMD |
| Housing Material | | PPS |
| Colour | | Gray |
| Weight | [gm] | 2 |

*Value applying at rated voltage