

## LCU80C051Ap/Dp/Gp

LCU80xx SERIES LASER DIODE

### ■ Features

1. Low operation current
2. High reliability
3. Low divergence angle
4. Standard optical power output : 300mW (CW)
5. TO-56 (  $\phi$  5.6mm) Packaged, with Pb-free window cap.

### ■ Applications

1. Motion sensor
2. Medical application
3. Pumping source for solid state laser
4. Infrared illumination
5. Industrial application

### ■ External dimensions(Unit : mm)

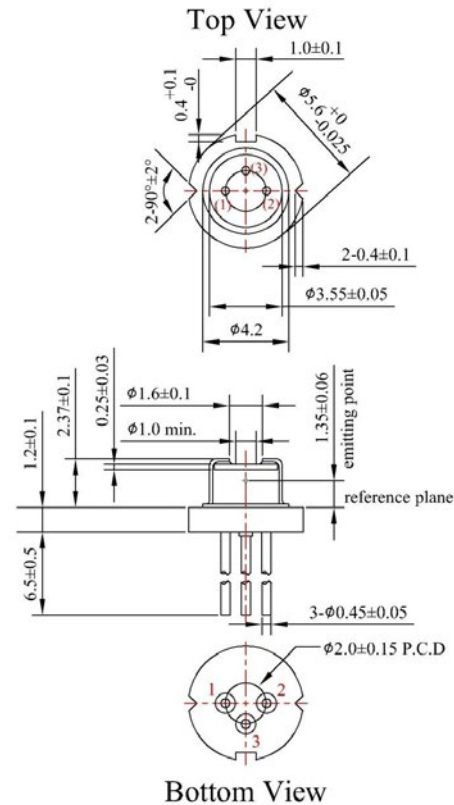
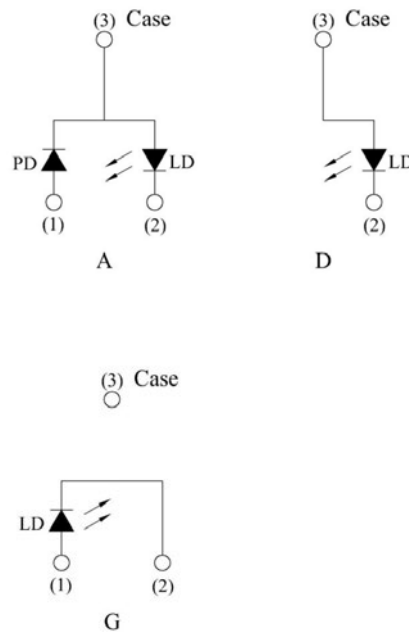

### ■ Absolute Maximum Ratings(Tc=25°C)

Ver.C

## LCU80C051Ap/Dp/Gp

LCU80xx SERIES LASER DIODE

Parameter	Symbol	Rating	Unit
Optical Output	Po	<b>330</b>	mW
Reverse Voltage	Vr	<b>2</b>	V
Operating Temperature ( Case )	Top	-10~+50	°C
Storage Temperature	Tstg	-40~+85	°C

### ■ Electrical and Optical Characteristics(Tc=25°C)

Parameter	Symbol	Condition	Min.	Typ.	Max.	Unit	
Threshold Current	Ith	Po=300mW	-	<b>60</b>	-	mA	
Operating Current	Iop	Po=300mW	-	<b>330</b>	<b>350</b>	mA	
Operating Voltage	Vop	Po=300mW	-	<b>1.9</b>	<b>2.1</b>	Volts	
Slope Efficiency	$\eta$	Po=75-225mW	<b>0.95</b>	<b>1.1</b>	-	mW/mA	
Monitir current	Im	Po=300mW	-	<b>0.6</b>	<b>2.0</b>	mA	
Beam Divergence (FWHM)	Parallel	$\theta_{//}$	Po=300mW	-	<b>7</b>	-	deg.
	Perpendicular	$\theta_{\perp}$	Po=300mW	-	<b>28</b>	-	deg.
Lasing Wavelength	$\lambda$	Po=300mW	<b>805</b>	<b>808</b>	<b>811</b>	nm	

©  $\theta_{//}$  and  $\theta_{\perp}$  are defined as the angle within which the intensity is 50% of the peak value.

### ■ Quality Notice

This device is still under product development.

### ■ Typical characteristic curves

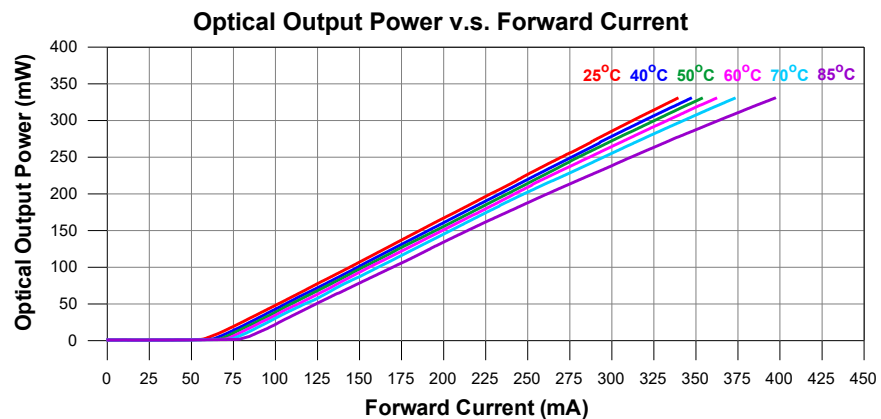

Ver.C

## LCU80C051Ap/Dp/Gp

LCU80xx SERIES LASER DIODE

Forward Voltage v.s. Forward Current

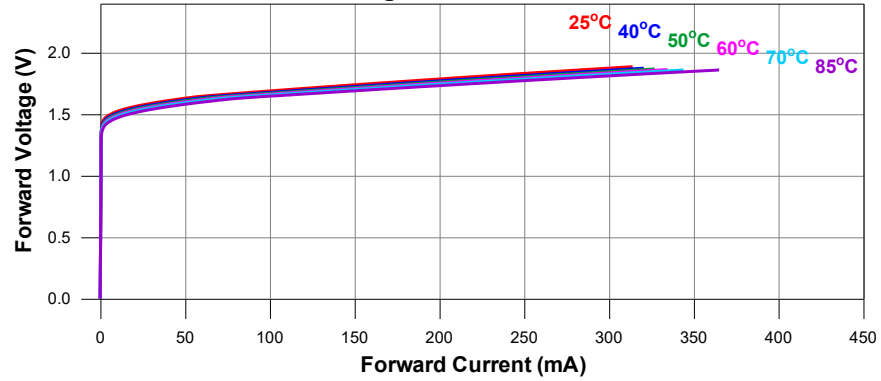

Peak Wavelength v.s. Case Temperature

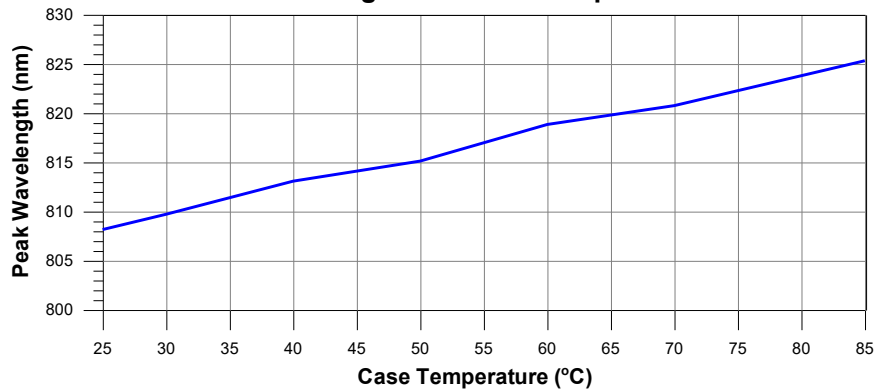

Far-Field Pattern

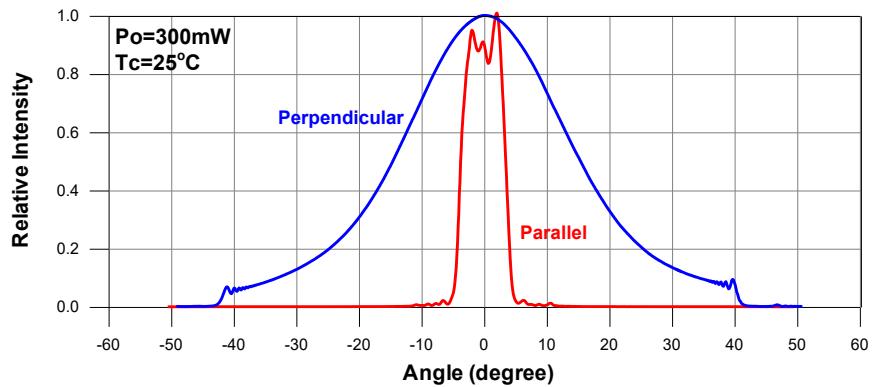

Ver.C

## LCU80C051Ap/Dp/Gp

LCU80xx SERIES LASER DIODE

Monitor Current v.s. Optical Output Power

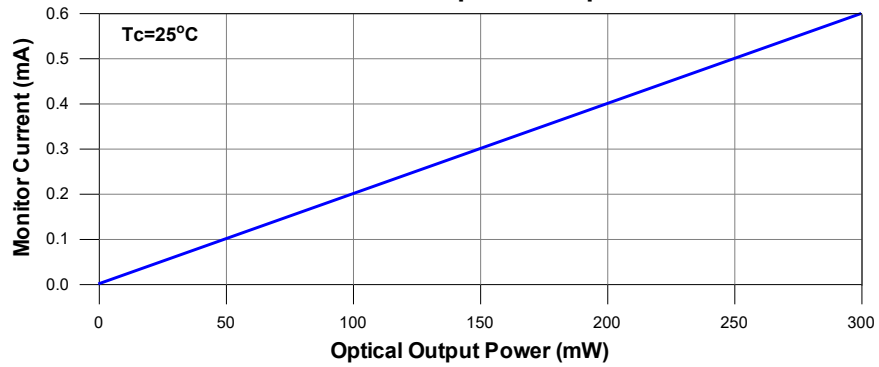

Slope Efficiency v.s. Case Temperature

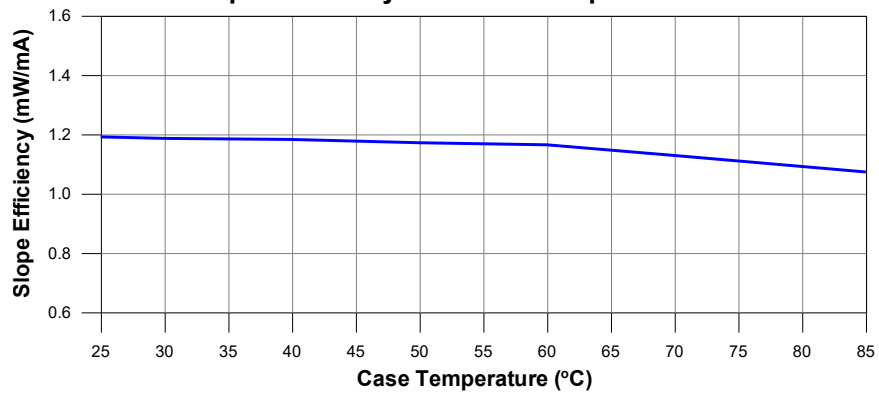

Threshold Current v.s. Case Temperature

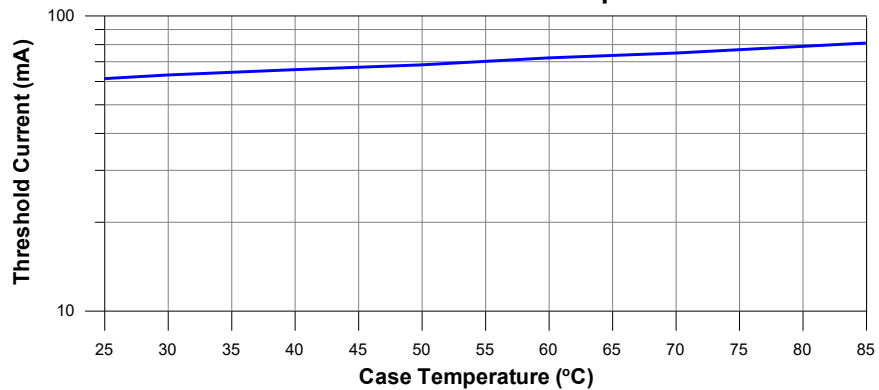

Ver.C

SPECIFICATIONS ARE SUBJECT TO CHANGE WITHOUT NOTICE.