



**SINK HERO**



**Beste Performance**

Dank des optimalen Hinterschliffs

**Best performance**

*Due to the optimal relief*

**El mejor rendimiento**

*Gracias al talón óptimo*

**Herausragende Ergebnisse**

Präzise Bohrleistungen sorgen für ein perfektes Senkbild

**Outstanding results**

*Precise drilling performance ensures a perfect surface*

**Resultados excelentes**

*Las potencias de perforación precisas crean una imagen perforada perfecta*

**Ruhiger Lauf**

Rattermarken werden vermieden

**Smooth running**

*Avoiding chatter marks*

**Funcionamiento tranquilo**

*prevención de marcas por vibraciones*



**alpen** *drill better.*

**D** HSS Kegelsenker,  
ungleiche Teilung,  
DIN 335 C, 90°

**Einsatzbereich:**

Für alle E- und NE-Metalle, Kunststoffe hart und weich. Universell einsetzbares Entgrat- und Senkwerkzeug für Bohrungen aller Art. Sehr gute Schneideigenschaften durch ungleichgeteilte Schneiden. Verringerung der Vorschubkraft und Ratterbildung an der Senkoberfläche durch reduzierte Axial- und Radialkraft.



Hitzebeständig  
Heat resistant  
Termoestable



Präzise  
Precise  
Preciso



Industriequalität  
Industrial quality  
Calidad industrial

**E** HSS countersinks,  
different partition,  
DIN 335 C, 90°

**Range of application:**

For ferrous and non-ferrous metals, synthetic materials soft and hard. Universal deburring and sink tool for all kind of borings. Excellent cutting features guarantee a smooth surface by unequally divided cutting edges. Reduction of feed force and chatter marks on the countersinking surface due to reduced axial and radial force.

**ES** Avellanador cónico HSS,  
división irregular,  
DIN 335 C, 90°

**Ámbito de aplicación:**

Para todos los metales E y NE y plásticos duros y blandos. Herramienta para desbarbar y avellanar de aplicación universal para agujeros de todo tipo. Excelentes características de corte, por corte desigual dividida. Reducción del avance y de vibración en la superficie avellanada gracias a las fuerzas axiales y radiales reducidas.



Einzelverpackung mit Aufhänger  
Single pack with tag  
Embalaje individual con gancho para autoservicio

d1	d4		d2 <sub>H9</sub>	l1	Z	Code 2320	Inh.
mm	mm		mm	mm		Art.-Nr.	Cont.
6,30	1,50	M 3	5,00	45	0	0232000630100	1
8,30	2,00	M 4	6,00	50	0	0232000830100	1
10,40	2,50	M 5	6,00	50	0	0232001040100	1
12,40	2,80	M 6	8,00	56	0	0232001240100	1
16,50	3,20	M 8	10,00	60	0	0232001650100	1
20,50	3,50	M 10	10,00	63	0	0232002050100	1
25,00	3,80	M 12	10,00	67	0	0232002500100	1
31,00	4,20		12,00	71	0	0232003100100	1

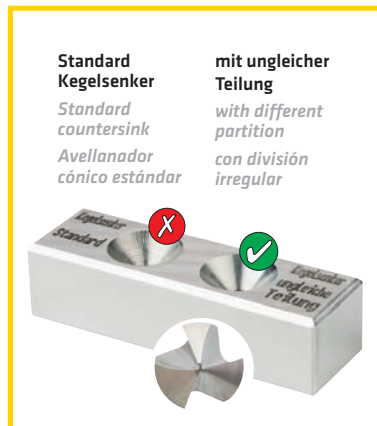

Gewinde-, Senk- und Schälwerkzeuge  
Taps, dies, countersinks and conecut  
herramientas para roscar, avellanar y escarpar

Ⓛ Kassetten, Sets

Ⓔ Cassettes, sets

Ⓔ Cajas, juegos

HSS Kegelsenker-Satz KP 3

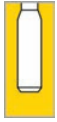

3-tlg. / 3-pcs. / 3-unid.  
Kunststoffbox / Plastic box / Caja de plástico  
Art.-Nr. 0232000003100

Ø mm	Stk. <sup>(1)</sup> pc. <sup>(1)</sup>
Sink Hero	
Ø 12,40 / 16,50 / 20,50	1

HSS Kegelsenker-Satz KM 6



6-tlg. / 6-pcs. / 6-unid.  
Metallkassette / Metal cassette / Caja de metal  
Art.-Nr. 0232000006100

Ø mm	Stk. <sup>(1)</sup> pc. <sup>(1)</sup>
Sink Hero	
Ø 6,30 / 8,30 / 10,40 / 12,40 / 16,50 / 20,50	1

<sup>(1)</sup> Stück je Abmessung / Pieces each dimension / Piezas por diámetro

**D HSS Kegelsenker,  
DIN 335 C, 90°**

**Einsatzbereich:**

Für alle E- und NE-Metalle, Kunststoffe hart und weich. Universell einsetzbares Entgrat- und Senkwerkzeug für Bohrungen aller Art. Sehr gute Schneideigenschaften ohne "Rat-termarken", durch radialen Hinterschliff leicht nachschärfbar an der Spanfläche.



Hitzebeständig  
Heat resistant  
Termoestable



Präzise  
Precise  
Preciso



Industriequalität  
Industrial quality  
Calidad industrial

**E HSS countersinks,  
DIN 335 C, 90°**

**Range of application:**

For ferrous and non-ferrous metals, synthetic materials soft and hard. Universal deburring and sink tool for all kind of borings. Excellent cutting features guarantee a smooth surface without burrs; profile relief facilitates an easy regrind.

**ES Avellanador cónico HSS,  
DIN 335 C, 90°**

**Ámbito de aplicación:**

Para todos los metales E y NE y plásticos duros y blandos. Herramienta para desbarbar y avellanar de aplicación universal para agujeros de todo tipo. Excelentes características de corte sin "rayado transversal", fácil reafileado de la superficie de deslizamiento gracias al talón radial.

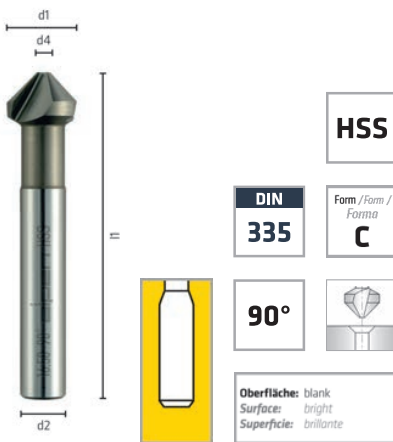

Einzelverpackung mit Aufhänger  
Single pack with tag  
Embalaje individual con gancho para autoservicio

d1 mm	d4 mm		d2 <sub>h9</sub> mm	l1 mm	Z	Code 2292 Art.-Nr.	Inh. Cont.
6,30	1,50	M 3	5,00	45	3	0229200630100	1
8,30	2,00	M 4	6,00	50	3	0229200830100	1
10,40	2,50	M 5	6,00	50	3	0229201040100	1
12,40	2,80	M 6	8,00	56	3	0229201240100	1
16,50	3,20	M 8	10,00	60	3	0229201650100	1
20,50	3,50	M 10	10,00	63	3	0229202050100	1
25,00	3,80	M 12	10,00	67	3	0229202500100	1



Gewinde-, Senk- und Schälwerkzeuge  
Taps, dies, countersinks and conecut  
herramientas para roscar, avellanar y escarpar

Ⓛ Kassetten, Sets

Ⓔ Cassettes, sets

Ⓔ Cajas, juegos

HSS Kegelsenker-Satz KM 3



3-tlg. / 3-pcs. / 3-unid.  
Kunststoffbox / Plastic box / Caja de plástico  
Art.-Nr. 0229200003100

Ø mm	Stk. <sup>(1)</sup> pc. <sup>(1)</sup>
HSS Kegelsenker	
Ø 12,40 / 16,50 / 20,50	1

HSS Kegelsenker-Satz KM 6



6-tlg. / 6-pcs. / 6-unid.  
Metallkassette / Metal cassette / Caja de metal  
Art.-Nr. 0229200096100

Ø mm	Stk. <sup>(1)</sup> pc. <sup>(1)</sup>
HSS Kegelsenker	
Ø 6,30 / 8,30 / 10,40 / 12,40 / 16,50 / 20,50	1

<sup>(1)</sup> Stück je Abmessung / Pieces each dimension / Piezas por diámetro

**D HSS Cobalt Entgratsenker mit Querlochbohrung**

**Einsatzbereich:**

Die günstige Schneidengeometrie ergibt einen leichten schälenden Schnitt. Die Späne werden in Schafrichtung abgeführt und können die Senkung nicht beschädigen. Zum leichten und ratzerfreien Entgraten von Bohrungen. Besonders geeignet für weiche langspanende Werkstoffe.



Verschleißfest  
Wear-resistant  
Resistente al desgaste



Präzise  
Precise  
Preciso

**E HSS Cobalt slotted countersink hole type**

**Range of application:**

Countersink and deburring tool with through hole which is ideal for long chip materials, such as aluminium and very effective on both hard and softwoods. Spoil is removed through centre of cutter to prevent damage to tool.

**ES Broca avellanadora para desbarbar HSS Cobalt con taladro para agujeros transversales**

**Ámbito de aplicación:**

La geometría de corte idónea facilita un corte escarpado. Las virutas se eliminan en la dirección del eje y no pueden causar daños en el avellanado. Para el desbarbado de agujeros fácil y sin vibraciones. Especialmente adecuada para materiales blandos de virutas largas.

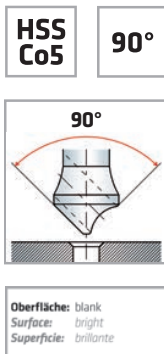

Drehpack mit Aufhänger  
Twistpack with tag  
Paquete giratorio con gancho para autoservicio

Größe Size / Tamaño	d1 mm	d2 mm	Bereich / Range Intervalo Ø mm	Code 2291 Art.-Nr.	Inh. Cont.
1	10,00	6	2-5	0229101000100	1
2	14,00	8	5-10	0229101400100	1
3	21,00	10	10-15	0229102100100	1
4	28,00	12	15-20	0229102800100	1
5	35,00	15	20-25	0229103500100	1

**HSS Cobalt Querlochsensersatz BOX 3**



3-tlg. / 3-pcs. / 3-unid.  
Kunststoffbox / Plastic box / Caja de plástico  
Art.-Nr. 0229100003100

Ø mm	Stk. <sup>(1)</sup> pc. <sup>(1)</sup>
HSS Cobalt Ø 10,00 / 14,00 / 21,00	1

<sup>(1)</sup> Stück je Abmessung / Pieces each dimension / Piezas por diámetro



Gewinde-, Senk- und Schälwerkzeuge  
Taps, dies, countersinks and conecut  
herramientas para roscar, avellanar y escarpar

**D** HSS Kegelsenker 90° mit 1/4"-Sechskantschaft

**Einsatzbereich:**

Zum Senken, Anfasen und Entgraten, für Metall- und Kunststoffbearbeitung. Zur direkten Verwendung in Elektro-Handbohrmaschinen, Elektro-Schraubern und Akku-Maschinen mit Sechskantaufnahme oder über magnetischen Universalhalter.



Verschleißfest  
Wear-resistant  
Resistente al desgaste



Präzise  
Precise  
Preciso

**E** HSS countersink 90° with 1/4" hexagonal shank

**Range of application:**

Countersink and deburring tool suitable for either metal or synthetic materials. Manufactured with 1/4" hexagonal shank for direct use in standard chuck, cordless drills or through a magnetic bit holder.

**E5** Avellanador cónico HSS, 90° con eje hexagonal 1/4"

**Ámbito de aplicación:**

Para el avellanado, el biselado y el desbarbado, para el procesamiento de metal y plástico. Para su uso directo en taladradoras manuales eléctricas, destornilladores eléctricos y máquinas a batería con toma hexagonal o mediante soporte universal magnético.

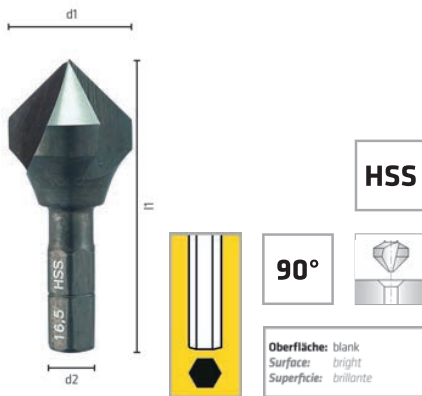

Drehpack mit Aufhänger  
Twistpack with tag  
Paquete giratorio con gancho para autoservicio

d1 mm			l1 mm	Z	Code 720 Art.-Nr.	Inh. Cont.
6,30	M 3	1/4"	31	3	0072000630100	1
8,30	M 4	1/4"	31	3	0072000830100	1
10,40	M 5	1/4"	34	3	0072001040100	1
12,40	M 6	1/4"	35	3	0072001240100	1
16,50	M 8	1/4"	40	3	0072001650100	1
20,50	M 10	1/4"	41	3	0072002050100	1

**HSS Senkerbitsatz BOX 3**



3-tlg. / 3-pcs. / 3-unid.  
Kunststoffbox / Plastic box / Caja de plástico  
Art.-Nr. 007200003100

Ø mm	Stk. <sup>(1)</sup> pc. <sup>(1)</sup>
HSS	
Ø 12,40 / 16,50 / 20,50	1

<sup>(1)</sup> Schaft nach DIN 3126, Form C6.3, ISO 1173  
Shank DIN 3126, Form C6.3, ISO 1173  
Eje según DIN 3126, forma C6.3, ISO 1173

<sup>(1)</sup> Stück je Abmessung / Pieces each dimension / Piezas por diámetro