

May.1.2017 Copyright 2017 HIROSE ELECTRIC CO., LTD. All Rights Reserved.

1		2			3			4		
COUNT	DESCRIPTION OF REVISIONS	BY	CHKD	DATE	COUNT	DESCRIPTION OF REVISIONS	BY	CHKD	DATE	
△					△					
△					△					
△					△					

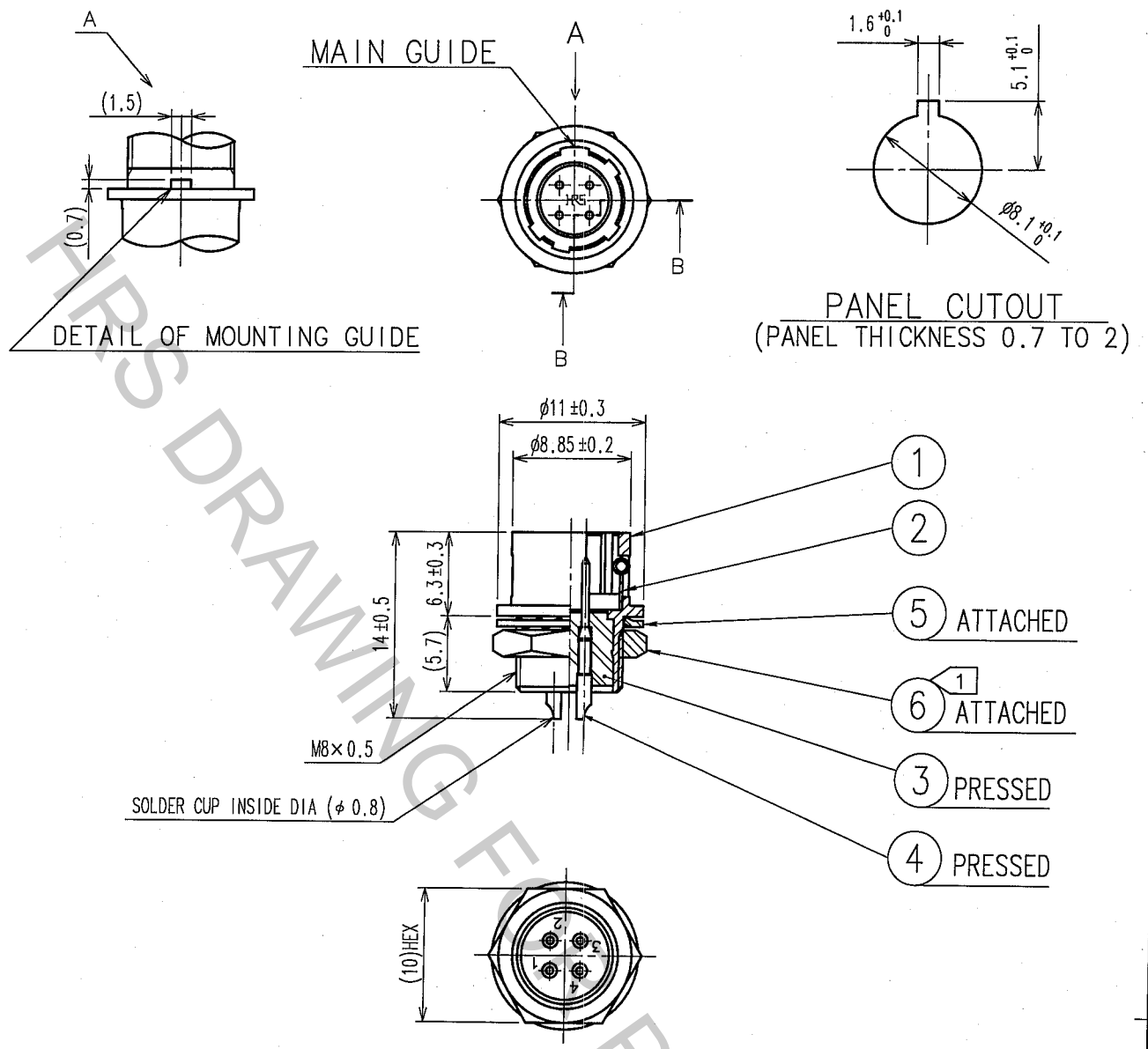

NOTE: ① THE RECOMMENDED CLAMP TORQUE OF REF.NO. ⑥ : 1.5 N · m
 LOCTITE 242, LOCTITE OR EQUIVALENT IS RECOMMENDED TO
 PREVENT REF.NO. ⑥ FROM LOOSENING.

3	POLYAMIDE	(BLACK)	UL94V-0	6	BRASS	NICKEL PLATING
2	STAINLESS STEEL			5	PHOSPHOR BRONZE	NICKEL PLATING
1	ZINC ALLOY	MATTE FINISH NICKEL PLATED		4	BRASS	SILVER PLATING 2μ m min
NO.	MATERIAL	FINISH, REMARKS		NO.	MATERIAL	FINISH, REMARKS

CODE NO. (OLD) CL		DRAWN T. HORII 05.12.9	DESIGNED T. Magomo 05.12.09	CHECKED E. Kunita 05.12.09	APPROVED M. Sato 05.12.10	RELEASED
DRAWING NO. EDC4-020539-73		PART NO. HR10A-7R-4P(73)				
SACLE 2 : 1		CODE NO. CL110-0306-6-73				1 1
UNITS mm		HRS HIROSE ELECTRIC CO., LTD.				

TO
R