

## Overview

The KEMET GTX plastic case filters cover single-phase EMC requirements with a wide variety of characteristics. By using nanocrystalline core material, these filters achieve excellent attenuation characteristics in a compact size. In addition, 6 different combinations of Y capacitors can be selected to support various inverter topologies. These filters are compact and lightweight due to its high mechanical density.

## Applications

- Industrial equipment
- General purpose inverter
- Medical equipment
- Commercial equipment

## Benefits

- Single-phase 250 VAC
- Current range from 6 to 30 A
- Nanocrystalline core material
- Selection of Y capacitors combinations
- Compact and lightweight
- Operating temperature range from -25°C to +55°C
- UL, c-UL, and TÜV approved
- RoHS compliant



## Part Number System

| GTX-   | 2                | 060-                    | Y00   |
|--------|------------------|-------------------------|---|
| Series | Phase            | Rated Current (A)       | Class Y Capacitors  |
| GTX    | 2 = Single-phase | 0x0 = x A<br>xx0 = xx A | Y00 = C <sub>y</sub> 1: None, C <sub>y</sub> 2: None<br>Y02 = C <sub>y</sub> 1: None, C <sub>y</sub> 2: 2,200 pF<br>Y03 = C <sub>y</sub> 1: None, C <sub>y</sub> 2: 3,300 pF<br>Y0X = C <sub>y</sub> 1: None, C <sub>y</sub> 2: 10,000 pF<br>Y22 = C <sub>y</sub> 1: 2,200 pF, C <sub>y</sub> 2: 2,200 pF<br>YXX = C <sub>y</sub> 1: 10,000 pF, C <sub>y</sub> 2: 10,000 pF |

**Dimensions – Millimeters**

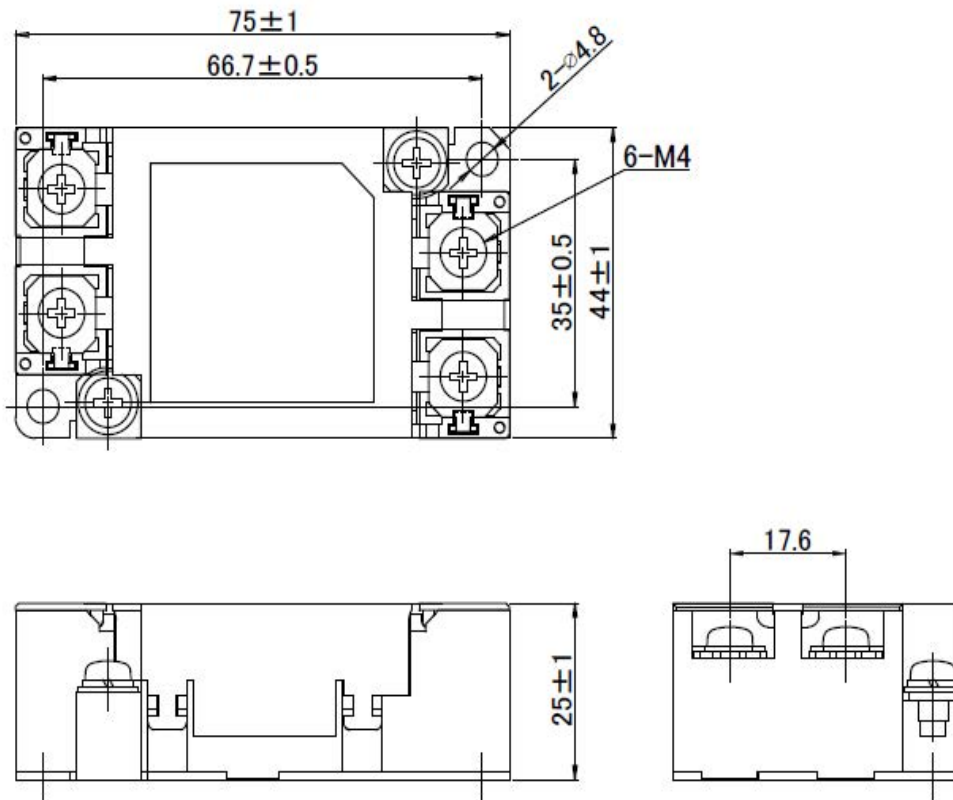

**Environmental Compliance**

KEMET GTX EMI-RFI Filters are RoHS compliant.



**Approvals**

| Certification Body       | File Number | Part Number             |
|--------------------------|-------------|-------------------------|
| UL/cUL                   | E506378     | All GTX EMI-RFI Filters |
| TÜV Rheinland Japan Ltd. | R50457083   | All GTX EMI-RFI Filters |

## Performance Characteristics

| Item                        | Performance Characteristics                          |
|-----------------------------|--|
| Rated Voltage               | 250 VAC (50/60Hz) and 560 VDC <sup>1</sup>           |
| Rated Current Range         | 6 – 30 A   |
| Withstanding Voltage        | 1,500 VAC (1 minute, line to ground)                 |
| Insulation Resistance       | 300 MΩ minimum at 500 VDC (1 minute, line to ground) |
| Leakage Current Range       | 0.01 – 4.60 mA maximum at 250 V/60 Hz                |
| Input/Output Terminal Type  | Screw  |
| Operating Temperature Range | -25°C to +55°C (not including self temperature rise) |

<sup>1</sup> Rated DC voltage is not allowed to approval standards.

### Table 1 – Ratings & Part Number Reference

| Part Number  | Phase        | Rated Voltage AC/DC <sup>1</sup> (V) | Rated Current AC/DC (A) | Leakage Current at 250V/60 Hz (mA) Maximum | Temperature Rise (K) Maximum | Operating Temperature Range | Terminal Type | Approval          | Weight (g) |
|--------------|--------------|--------------------------------------|-------------------------|--|------------------------------|-----------------------------|---------------|-------------------|------------|
| GTX-2060-Y00 | Single-phase | AC250/DC560                          | 6                       | 0.01                                       | 60                           | -25°C to +55°C              | Screw         | UL, c-UL, and TÜV | 123        |
| GTX-2060-Y02 | Single-phase | AC250/DC560                          | 6                       | 0.50                                       | 60                           | -25°C to +55°C              | Screw         | UL, c-UL, and TÜV | 123        |
| GTX-2060-Y03 | Single-phase | AC250/DC560                          | 6                       | 0.75                                       | 60                           | -25°C to +55°C              | Screw         | UL, c-UL, and TÜV | 124        |
| GTX-2060-Y0X | Single-phase | AC250/DC560                          | 6                       | 2.30                                       | 60                           | -25°C to +55°C              | Screw         | UL, c-UL, and TÜV | 125        |
| GTX-2060-Y22 | Single-phase | AC250/DC560                          | 6                       | 1.00                                       | 60                           | -25°C to +55°C              | Screw         | UL, c-UL, and TÜV | 125        |
| GTX-2060-YXX | Single-phase | AC250/DC560                          | 6                       | 4.60                                       | 60                           | -25°C to +55°C              | Screw         | UL, c-UL, and TÜV | 127        |
| GTX-2100-Y00 | Single-phase | AC250/DC560                          | 10                      | 0.01                                       | 60                           | -25°C to +55°C              | Screw         | UL, c-UL, and TÜV | 121        |
| GTX-2100-Y02 | Single-phase | AC250/DC560                          | 10                      | 0.50                                       | 60                           | -25°C to +55°C              | Screw         | UL, c-UL, and TÜV | 122        |
| GTX-2100-Y03 | Single-phase | AC250/DC560                          | 10                      | 0.75                                       | 60                           | -25°C to +55°C              | Screw         | UL, c-UL, and TÜV | 122        |
| GTX-2100-Y0X | Single-phase | AC250/DC560                          | 10                      | 2.30                                       | 60                           | -25°C to +55°C              | Screw         | UL, c-UL, and TÜV | 124        |
| GTX-2100-Y22 | Single-phase | AC250/DC560                          | 10                      | 1.00                                       | 60                           | -25°C to +55°C              | Screw         | UL, c-UL, and TÜV | 123        |
| GTX-2100-YXX | Single-phase | AC250/DC560                          | 10                      | 4.60                                       | 60                           | -25°C to +55°C              | Screw         | UL, c-UL, and TÜV | 126        |
| GTX-2160-Y00 | Single-phase | AC250/DC560                          | 16                      | 0.01                                       | 60                           | -25°C to +55°C              | Screw         | UL, c-UL, and TÜV | 125        |
| GTX-2160-Y02 | Single-phase | AC250/DC560                          | 16                      | 0.50                                       | 60                           | -25°C to +55°C              | Screw         | UL, c-UL, and TÜV | 126        |
| GTX-2160-Y03 | Single-phase | AC250/DC560                          | 16                      | 0.75                                       | 60                           | -25°C to +55°C              | Screw         | UL, c-UL, and TÜV | 127        |
| GTX-2160-Y0X | Single-phase | AC250/DC560                          | 16                      | 2.30                                       | 60                           | -25°C to +55°C              | Screw         | UL, c-UL, and TÜV | 128        |
| GTX-2160-Y22 | Single-phase | AC250/DC560                          | 16                      | 1.00                                       | 60                           | -25°C to +55°C              | Screw         | UL, c-UL, and TÜV | 128        |
| GTX-2160-YXX | Single-phase | AC250/DC560                          | 16                      | 4.60                                       | 60                           | -25°C to +55°C              | Screw         | UL, c-UL, and TÜV | 130        |
| GTX-2200-Y00 | Single-phase | AC250/DC560                          | 20                      | 0.01                                       | 60                           | -25°C to +55°C              | Screw         | UL, c-UL, and TÜV | 128        |
| GTX-2200-Y02 | Single-phase | AC250/DC560                          | 20                      | 0.50                                       | 60                           | -25°C to +55°C              | Screw         | UL, c-UL, and TÜV | 129        |
| GTX-2200-Y03 | Single-phase | AC250/DC560                          | 20                      | 0.75                                       | 60                           | -25°C to +55°C              | Screw         | UL, c-UL, and TÜV | 129        |
| GTX-2200-Y0X | Single-phase | AC250/DC560                          | 20                      | 2.30                                       | 60                           | -25°C to +55°C              | Screw         | UL, c-UL, and TÜV | 131        |
| GTX-2200-Y22 | Single-phase | AC250/DC560                          | 20                      | 1.00                                       | 60                           | -25°C to +55°C              | Screw         | UL, c-UL, and TÜV | 130        |
| GTX-2200-YXX | Single-phase | AC250/DC560                          | 20                      | 4.60                                       | 60                           | -25°C to +55°C              | Screw         | UL, c-UL, and TÜV | 133        |
| GTX-2300-Y00 | Single-phase | AC250/DC560                          | 30                      | 0.50                                       | 60                           | -25°C to +55°C              | Screw         | UL, c-UL, and TÜV | 127        |
| GTX-2300-Y02 | Single-phase | AC250/DC560                          | 30                      | 0.50                                       | 60                           | -25°C to +55°C              | Screw         | UL, c-UL, and TÜV | 128        |
| GTX-2300-Y03 | Single-phase | AC250/DC560                          | 30                      | 0.75                                       | 60                           | -25°C to +55°C              | Screw         | UL, c-UL, and TÜV | 129        |
| GTX-2300-Y0X | Single-phase | AC250/DC560                          | 30                      | 2.30                                       | 60                           | -25°C to +55°C              | Screw         | UL, c-UL, and TÜV | 130        |
| GTX-2300-Y22 | Single-phase | AC250/DC560                          | 30                      | 1.00                                       | 60                           | -25°C to +55°C              | Screw         | UL, c-UL, and TÜV | 130        |
| GTX-2300-YXX | Single-phase | AC250/DC560                          | 30                      | 4.60                                       | 60                           | -25°C to +55°C              | Screw         | UL, c-UL, and TÜV | 132        |
| Part Number  | Phase        | Rated Voltage                        | Rated Current           | Leakage Current                            | Temperature Rise             | Operating Temperature Range | Terminal Type | Approval          | Weight     |

<sup>1</sup> Rated DC voltage is not allowed to approval standards

## Circuit Diagram

### Circuit Diagram

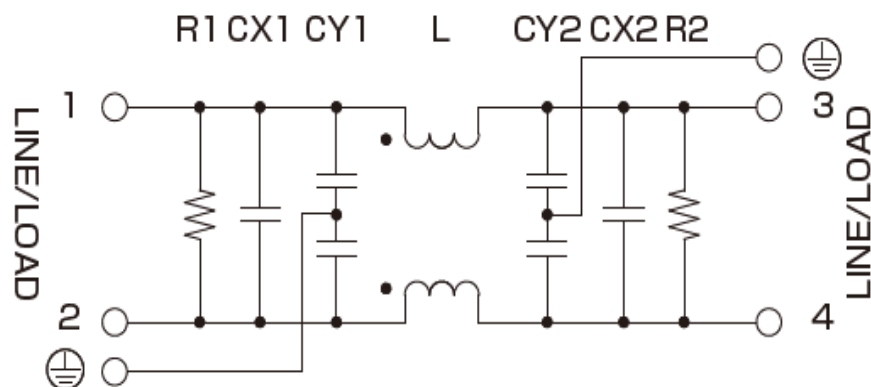

### Measuring Circuit - Common Mode

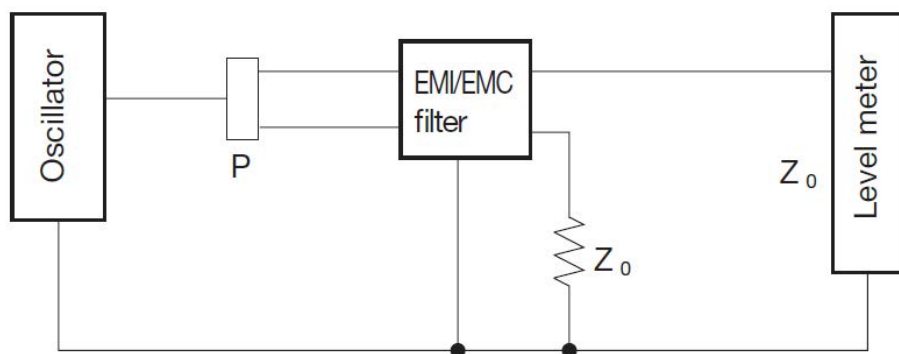

P: Power divider     $Z_0$ : 50Ω

## Attenuation (Static Characteristics)

**GTX-2060-\*\*\***

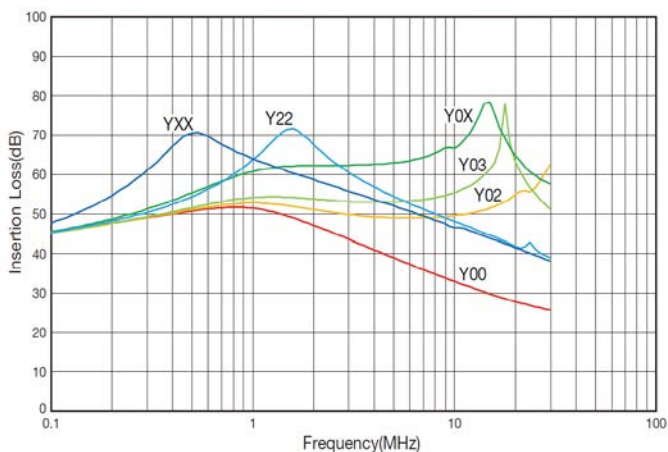

**GTX-2100-\*\*\***

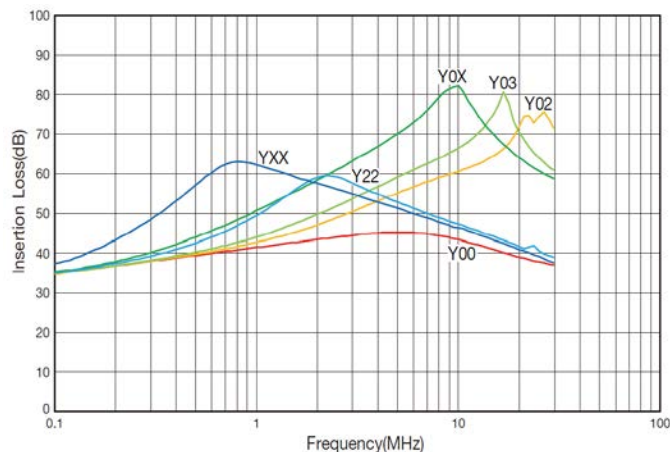

**GTX-2160-\*\*\***

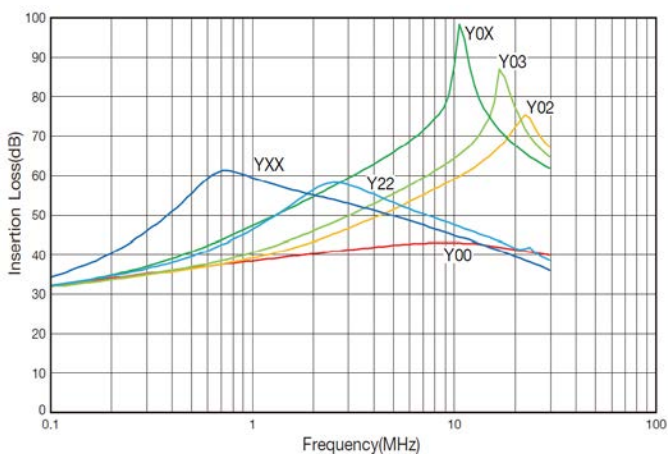

**GTX-2200-\*\*\***

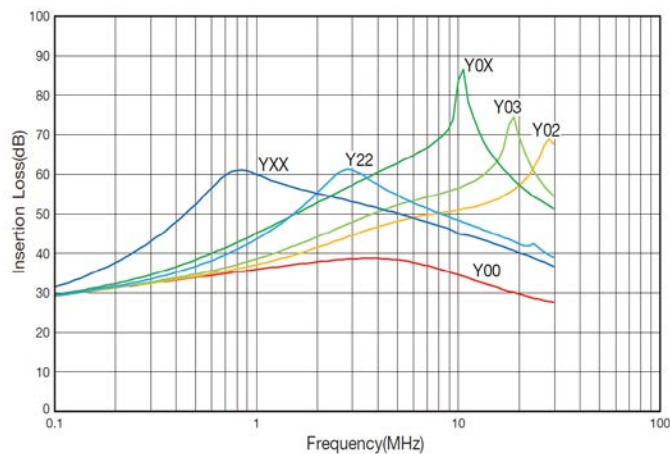

**GTX-2300-\*\*\***

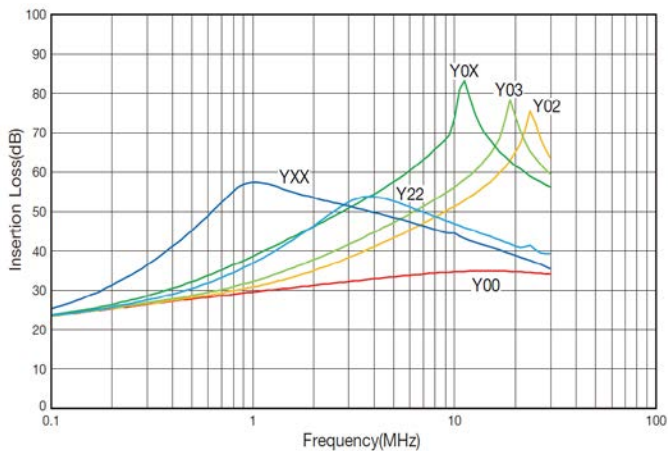

## Packaging

| Part Type    | Packaging Type | Pieces per Box |
|--------------|----------------|----------------|
| GTX-2**0-Y** | Box            | 30             |

---

## Handling Precautions

### Precautions for product storage

EMI-RFI Filters should be stored in normal working environments. While the filters themselves are quite robust in other environments, solderability will be degraded by exposure to high temperatures, high humidity, corrosive atmospheres, and long term storage.

KEMET recommends that maximum storage temperature not exceed 40°C and maximum storage humidity not exceed 70% relative humidity and atmospheres should be free of chlorine and sulfur bearing compounds. Temperature fluctuations should be minimized to avoid condensation on the parts. Also, avoid storage near strong magnetic fields as this might magnetize the product.

EMI-RFI Filters' stock should be used promptly, preferably within 12 months of receipt.

## KEMET Electronics Corporation Sales Offices

For a complete list of our global sales offices, please visit [www.kemet.com/sales](http://www.kemet.com/sales).

---

### Disclaimer

All product specifications, statements, information and data (collectively, the "Information") in this datasheet are subject to change. The customer is responsible for checking and verifying the extent to which the Information contained in this publication is applicable to an order at the time the order is placed. All Information given herein is believed to be accurate and reliable, but it is presented without guarantee, warranty, or responsibility of any kind, expressed or implied.

Statements of suitability for certain applications are based on KEMET Electronics Corporation's ("KEMET") knowledge of typical operating conditions for such applications, but are not intended to constitute – and KEMET specifically disclaims – any warranty concerning suitability for a specific customer application or use. The Information is intended for use only by customers who have the requisite experience and capability to determine the correct products for their application. Any technical advice inferred from this Information or otherwise provided by KEMET with reference to the use of KEMET's products is given gratis, and KEMET assumes no obligation or liability for the advice given or results obtained.

Although KEMET designs and manufactures its products to the most stringent quality and safety standards, given the current state of the art, isolated component failures may still occur. Accordingly, customer applications which require a high degree of reliability or safety should employ suitable designs or other safeguards (such as installation of protective circuitry or redundancies) in order to ensure that the failure of an electrical component does not result in a risk of personal injury or property damage.

Although all product-related warnings, cautions and notes must be observed, the customer should not assume that all safety measures are indicated or that other measures may not be required.

When providing KEMET products and technologies contained herein to other countries, the customer must abide by the procedures and provisions stipulated in all applicable export laws and regulations, including without limitation the International Traffic in Arms Regulations (ITAR), the US Export Administration Regulations (EAR) and the Japan Foreign Exchange and Foreign Trade Act.

*KEMET is a registered trademark of KEMET Electronics Corporation.*