

Type **O**
with clamping bolt retainer
for welding

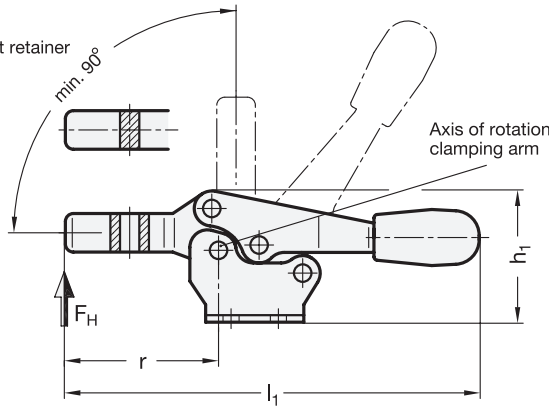

Type **M**
with two stepped
side washers



2 Type

- M** forked clamping arm
- O** solid clamping arm

1

Size	F _H in N Holding force	a ≈	b ₁	b ₂	b ₃	d ₁	d ₂	h ₁ ≈	h ₂	h ₃	h ₄
25*	400	10	24	24,5	4,3	M 4	4,3	23	12	7	15
75	900	20	28	26	5,5	M 5	4,5	37	20	11	22,5
130	1000	32	36	40	6,5	M 6	5,5	51	29	14	27
230	1600	37	44	42	8,5	M 8	6,5	61,5	36,5	18	35
355	3200	58	60	56	10,4	M 10	8,5	83	50	22	43
455	6200	65	70	65	12,4	M 12	8,5	98,5	60	26	53

Size	l ₁ ≈	l ₂ ≈	l ₃ ≈	l ₄ max.	m ₁	m ₂	m ₃	r	s ₁	s ₂
25	68	43	20	-	15	16	4,5	24,5	1,2	-
75	118	67	40	49,5	13,5	17	7,2	43	2	4
130	168	92	53	64	26	26	5	62	2,5	5
230	196	110	63,5	78	26	28,5	9	72	3	6
355	270	161	96	115	41	41	9,5	108,5	3,5	7
455	309	186	116	135	41,5	41,5	14,2	126	4	10

* Size 25 only available as type M.

Specification

- Parts in sheet metal
Case hardening steel C10
zinc plated, blue passivated
- Bearing pins tempered
- Bearing rivets (from size 355 upwards)
case hardened
- all moving parts
lubricated with special grease
- solid moulded plastic handle sleeve
red, oil resistant
- **RoHS compliant**

Accessory

- Clamping bolts → Page 765
- Holders for clamping bolts GN 809
(for type O) → Page 770
- Holders for clamping bolts GN 801
(for type M) → Page 771

Information

A special feature for the horizontal clamp GN 820 is its low profile in clamping position.

They are designed in such a way to avoid the operator's fingers being caught between the retracting clamping arm and the operating handle (safety distance).

Stepped side washers respectively clamping bolt retainers are included.

see also...

- *General information to toggle clamps* → Page 676
- *Stainless Steel-Horizontal clamps GN 820* → Page 702
- *Horizontal clamps GN 820.2* → Page 708

How to order

GN820-75-M

- | | |
|---|------|
| 1 | Size |
| 2 | Type |

