

GN 715.2

Eccentric bushings

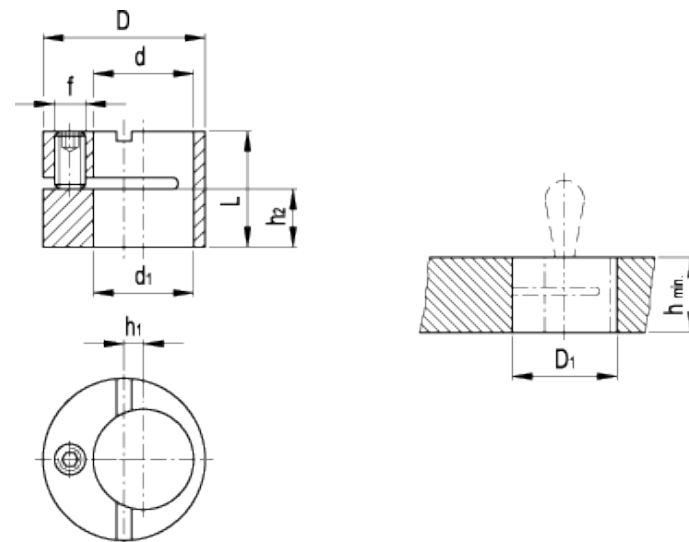
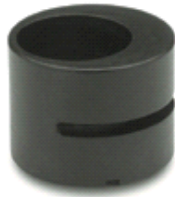

technical informations

Material

Black-oxide steel.

Features and applications

GN 715.2 eccentric bushings are used to position [GN 715](#) side thrust pins correctly. By using the eccentric bushings, the thrust pin can be positioned very precisely to adapt to the tolerance of the piece to be machined.

Standard Elements	Main dimensions									Weight
Description	d	$d_{1+0.1}$	D_{h9}	D_{1H7}	f	h	h_1	h_2	$L_{-0.2}$	g
GN 715.2-6	6	6.2	12	12	M4	10	2	4.4	9.9	5
GN 715.2-10	10	10.2	16	16	M4	12	2	5.4	11.9	9
GN 715.2-12	12	12.2	18	18	M4	14	2	6.6	13.9	13
GN 715.2-16	16	16.2	25	25	M6	18	3	7.9	17.9	35



ELESA and GANTER models all rights reserved in accordance with the law. Always mention the source when reproducing our drawings.

STANDARD MACHINE ELEMENTS WORLDWIDE