

GN 473

Foot clamp mountings

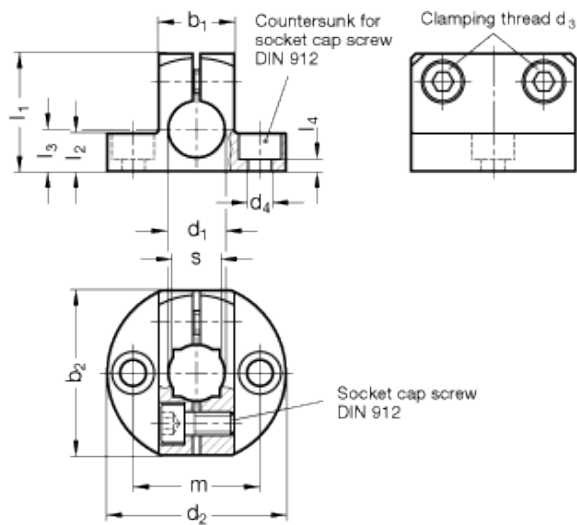

Adjustable clamping lever GN 511



Application example

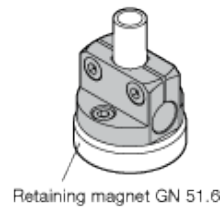

technical informations

Material
Aluminium.

Finish

- Version MT: matte, ground.
- Version ELS: anodised, black.

Clamping screws

AISI 304 stainless steel socket cap screws DIN 912.

Features and applications

The GN 473 foot clamp mountings have a horizontal and a vertical clamp bore, with the vertical clamp bore capable of holding additional square tubings.

The bore spacing m of the foot clamp mountings GN 473 is matched with the clamp mountings GN 477 and the flanged bolts GN 480 as well as GN 51.6 retaining magnets.

The standard clamping bolts are socket cap screws DIN 912. They can be replaced by adjustable clamping kits GN 511 (description see table of dimensions).

Accessories

Clamping kits [GN 511](#) (Clamping handles GN 300.1 with distance bushing).

Standard Elements	Main dimensions											Clamping kits	Weight
Description	d ₁ Bore B for shaft tol. h11	b ₁	b ₂	d ₂	d ₃ Clamping thread	d ₄ for screw	l ₁	l ₂	l ₃	l ₄	m	s Square V	for d ₃
GN 473-B8-MT	B8	14	29	31.5	M 4	M 4	20	7	7	3	22	-	GN 511-M4-14
GN 473-B10-MT	B10	16	35	38	M 5	M 5	24	8	8	2.5	27	8	GN 511-M5-16
GN 473-B12-MT	B12	16	35	38	M 5	M 5	25	8	8	2.5	27	10	GN 511-M5-16
GN 473-B15-MT	B15	20	41	45	M 6	M 6	30	10	10	4	32	12	GN 511-M6-20
GN 473-B16-MT	B16	20	41	45	M 6	M 6	31	10	10	4	32	-	GN 511-M6-20
GN 473-B20-MT	B20	25	44	50	M 6	M 6	35	12.5	12.5	6.5	36	16	GN 511-M6-25
GN 473-B8-ELS	B8	14	29	31.5	M 4	M 4	20	7	7	3	22	-	GN 511-M4-14
GN 473-B10-ELS	B10	16	35	38	M 5	M 5	24	8	8	2.5	27	8	GN 511-M5-16
GN 473-B12-ELS	B12	16	35	38	M 5	M 5	25	8	8	2.5	27	10	GN 511-M5-16
GN 473-B15-ELS	B15	20	41	45	M 6	M 6	30	10	10	4	32	12	GN 511-M 6-20
GN 473-B16-ELS	B16	20	41	45	M 6	M 6	31	10	10	4	32	-	GN 511-M6-20
GN 473-B20-ELS	B20	25	44	50	M 6	M 6	35	12.5	12.5	6.5	36	16	GN 511-M6-25



STANDARD MACHINE ELEMENTS WORLDWIDE