

ENH Series

Incremental manual handle type Rotary encoder

■ Features

- Suitable for manual pulse input type such as numerically controlled or milling machinery
- Terminal connection type
- Power supply: 5VDC ±5%, 12-24VDC ±5%

■ Applications

- Industrial tooling machinery



⚠ Please read "Caution for your safety" in operation manual before using.

■ Ordering information

ENH	-	100	-	1	-	T	-	24
Series		Pulse/1 Revolution		Clickstopper position		Control output		Power supply
Handle type		25 100		1: Normal "H" 2: Normal "L"		T: Totem pole output V: Voltage output L: Line driver output(※)		5: 5VDC ±5% 24: 12-24VDC ±5%

※The power of Line driver is only for 5VDC

■ Specifications

Item	Incremental manual handle type of rotary encoder			
Resolution(P/R) ※ ¹	25,100			
Electrical specification	Output phase	A, B phase(Line driver output A, \bar{A} , B, \bar{B} phase)		
	Phase difference of output	Phase difference between A and B: $\frac{T}{2} \pm \frac{T}{8}$ (T= 1cycle of A phase)		
	Control output	Totem pole output	<ul style="list-style-type: none"> • Low - Load current: Max. 30mA, Residual voltage: Max. 0.4VDC • High - Load current: Max. 10mA Output voltage(Power voltage 5VDC): Min. (Power voltage-2.0)VDC, Output voltage(Power voltage 12-24VDC): Min. (Power voltage-3.0) VDC	
		Voltage output	Load current: Max. 10mA, Residual voltage: Max. 0.4VDC	
		Line driver output	<ul style="list-style-type: none"> • Low - Load current: Max. 20mA, Residual voltage: Max. 0.5VDC • High - Load current: Max. -20mA, Output voltage: Min. 2.5VDC 	
	Response time (Rise/Fall)	Totem pole output	Max. 1μs	
		Voltage output		
		Line driver output	Max. 0.2μs	• Measuring condition - Cable length : 1m, I sink = 20mA
	Power supply	• 5VDC ±5%(Ripple P-P: Max.5%) • 12-24VDC ±5%(Ripple P-P: Max.5%)		
	Current consumption	Max. 40mA(disconnection of the load), Line driver output: Max. 50mA(disconnection of the load)		
	Max. Response frequency	10kHz		
Insulation resistance	Min. 100MΩ(at 500VDC megger between all terminals and case)			
Dielectric strength	750VAC 50/60Hz for 1 minute(Between all terminals and case)			
Connection	Terminal block type			
Mechanical specification	Starting torque	Max. 1kgf·cm(0.098N·m)		
	Shaft loading	Radial: 2kgf, Thrust: 1kgf		
	Max. allowable revolution ※ ²	Max. 200rpm(Normal), 600rpm(Peak)		
Vibration	1.5mm amplitude or 300m/s ² at frequency of 10 to 55Hz(for 1 min.) in each of X, Y, Z directions for 2 hours			
Shock	Approx. Max. 50G			
Ambient temperature	-10 to 70°C, storage : -25 to 85°C			
Ambient humidity	35 to 85%RH, storage : 35 to 90°C			
Protection	IP50(IEC standard)			
Weight※ ³	Approx. 330g(approx. 260g)			

※1: Not indicated type is customizable.

※2: Make sure that. Max response revolution should be lower than or equal to max. allowable revolution when selecting the resolution.
 [Max. response revolution(rpm)= $\frac{\text{Max. response frequency}}{\text{Resolution}} \times 60 \text{ sec}$]

※3: The weight with packaging and the weight in parentheses is only unit weight.

※Environment resistance is rated at no freezing or condensation.

Manual Handle Incremental type

Control output diagram

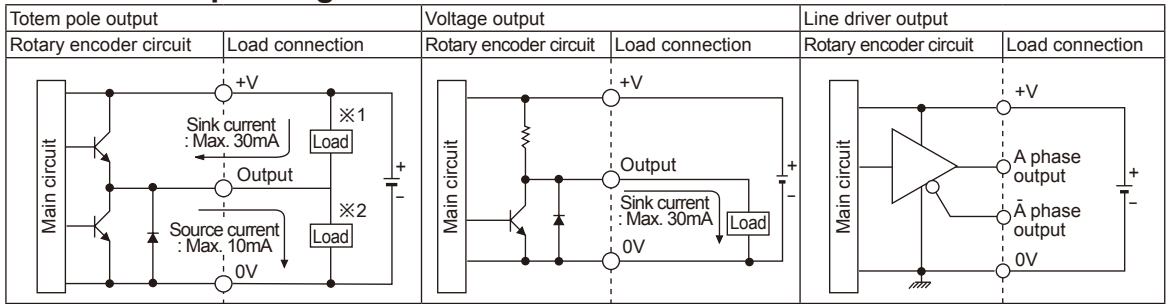

- The output circuits for A, B phase (Line driver output is A, \bar{A} , B, \bar{B} phase) are the same.
- Totem pole output can be used for NPN open collector type (※1) or voltage output type (※2).

Output waveform

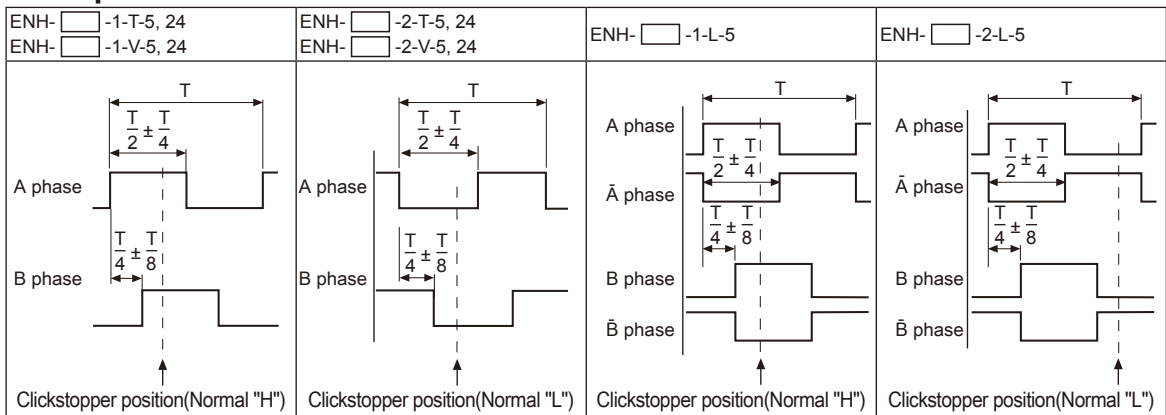

※Clickstopper position Normal "H" or Normal "L": It shows the waveform when the handle is not stopped.

Connections

• Totem pole output / Voltage output

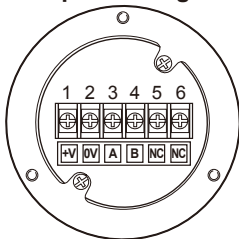

※Do not use terminal No. 5, 6.

• Line driver output

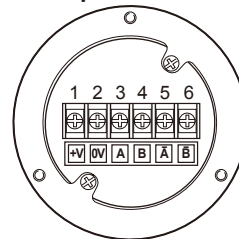

Dimensions

(unit: mm)

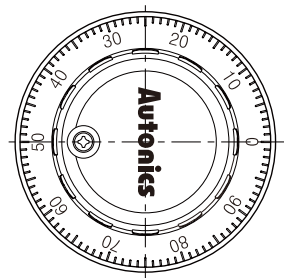
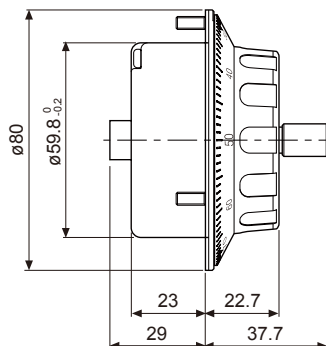
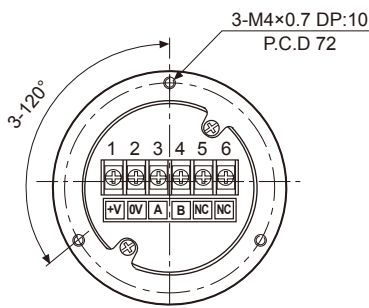

※ ϕ 70mm PCD mounting hole type is customizable.

- (A) Photo electric sensor
- (B) Fiber optic sensor
- (C) Door/Area sensor
- (D) Proximity sensor
- (E) Pressure sensor
- (F) Rotary encoder
- (G) Connector/Socket
- (H) Temp. controller
- (I) SSR/Power controller
- (J) Counter
- (K) Timer
- (L) Panel meter
- (M) Tacho/Speed/Pulse meter
- (N) Display unit
- (O) Sensor controller
- (P) Switching mode power supply
- (Q) Stepper motor & Driver & Controller
- (R) Graphic/Logic panel
- (S) Field network device
- (T) Software
- (U) Other