

INCL CONTROLLER SSD1311 FOR SPI AND I²C



Dimension 61x26x3.3mm

FEATURES

- 4x20 CHARACTER / ALTERNATIVELY 3x20 OR 2x20 WITH DOUBLE HEIGHT FONT
- CONTRASTY OLED DISPLAY (TYP. 170° VIEWING ANGLE)
- INTEGRATED CONTROLLER SSD1311
- SINGLE SUPPLY 3.3V OR 5V
- SPI-INTERFACE (3-WIRE): MOSI, CLK, CS
- I²C INTERFACE: SDA, SCL
- EXTREME WIDE TEMPERATURE RANGE (T_{OP} -40°C - +80°C)
- NO SPECIAL ASSEMBLY NECESSARY: SIMPLY SOLDER INTO PCB
- 3 VERSIONS AVAILABLE: WITH / WITHOUT POLARISER AND COVER GLASS
- FAST RESPONSE TIME (10µs), NO AFTERGLOW EFFECT

ORDERING CODE

- | | |
|---|------------------------|
| • OLED TEXT 4x20, yellow, black background, incl. cover glass | EA OLEDM204-GGA |
| • OLED TEXT 4x20, yellow, black background, no cover glass | EA OLEDM204-LGA |
| • OLED TEXT 4x20, white, black background, no cover glass | EA OLEDM204-LWA |

FROM A MINIMUM QUANTITY OF 500 PCS.

- | | |
|--|------------------------|
| • SPECIAL COLORS OLED TEXT 4x20, with polariser (no cover glass) | EA OLEDM204-LxA |
| X: G = Green | |
| B = Blue | |

ACCESSORIES

- | | |
|---|---------------------|
| • TEST BOARD WITH USB INTERFACE | EA 9781-1USB |
| • SOCKET 4.8mm HEIGHT (2 PCS. ARE REQUIRED) | EA FL-10P |

EA OLED SERIES

With its EA OLED series ELECTRONIC ASSEMBLY launches worldwide the first display family with OLED-technology for direct mounting and soldering. In comparison to standard displays there's no FFC/FPC cable/connector that may loose contact, this OLED series will be soldered directly or put into a standard 2.54 mm precision socket.

It is designed for compact handheld equipment and provides a lot real advantages:

- Extreme compact (68x51mm) with a large viewing area (64x37mm)
- Super flat with 2.4 mm (without frontal protection glass)
- SPI and I²C interface
- Simple mounting with direct soldering
- Ex stock available from 1 pc. off
- Long life time (80,000 h for yellow)
- Extreme wide temperature range (-40..+80°C)
- Fast response time (10µs), no afterglow

VERSIONS

The EA OLEDM204 is available in 3 different versions:

EA OLEDM204-GGA / Allround

This module is perfect for rough environment. An additional frontal glass protects the display against scratch, shock and UV light. Thanks to its integrated polariser there's no need for an additionally smoked glass.

EA OLEDM204-LGA / Flat

This module is the standard module and does fit for the most applications. The flat design (2.4 mm) makes the display perfect for smallest equipment. The background is always deep black for best contrast.

EA OLEDM204-LWA / White and Flat

This module is the standard module and does fit for the most applications. The white colored text and the flat design (2.4 mm) makes the display perfect for smallest equipment. The background is always deep black for best contrast.

COLORS (CUSTOM MADE)

The standard colors are yellow and white.

The flat version EA OLEDM204-LGA is on customers request available in 3 more colors. The minimum order quantity is 500 pcs. and lead time is about 20 weeks. Samples are normally available ex stock.

Interface and software are 100% compatible. The yellow color provides highest brightness and longest life time.



EA OLEDM204-LEA



EA OLEDM204-LBA

APPLICATION EXAMPLES

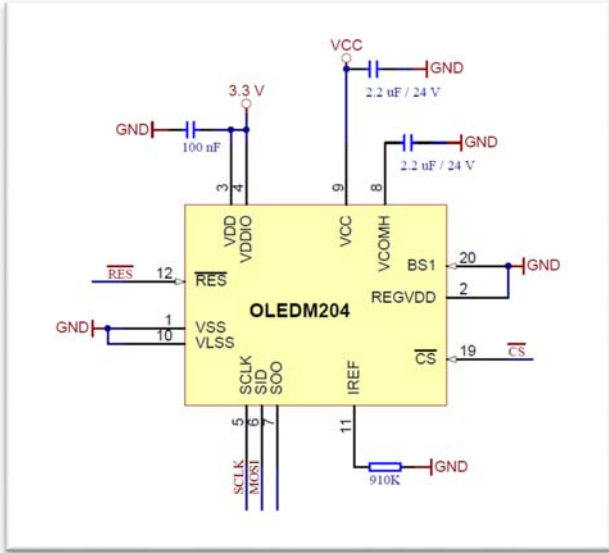

SPI - 3.3V

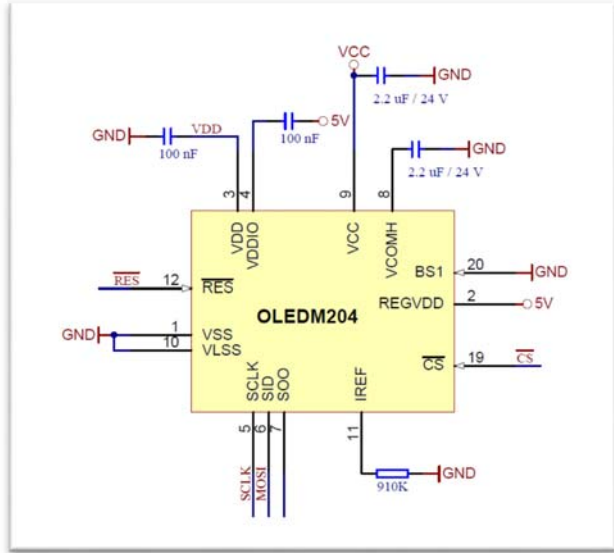

SPI - 5V

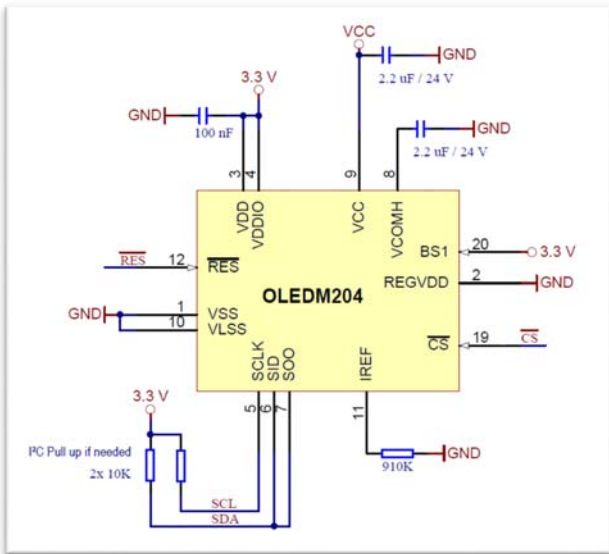

I2C - 3.3V - Address 0x78 (0x3C)

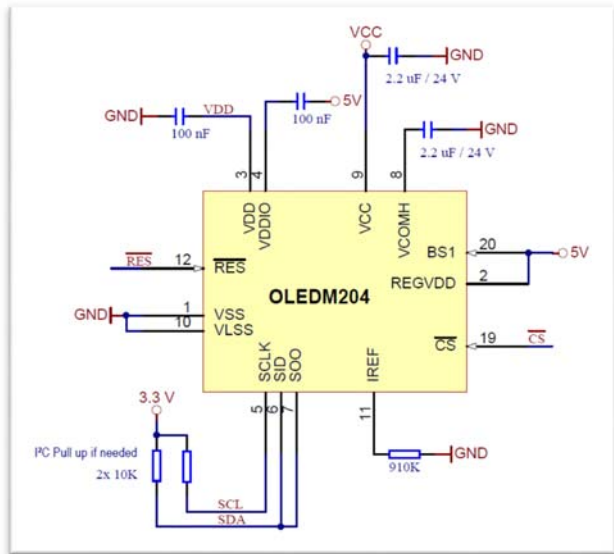

I2C - 5V - Address 0x78 (0x3C)

DATA TRANSFER 3-WIRE SPI (8 BIT)

Data transmission for SPI is unidirectional, that means that data can only be written, there's no data read option. Selection for writing data or command is done with the DC bit.

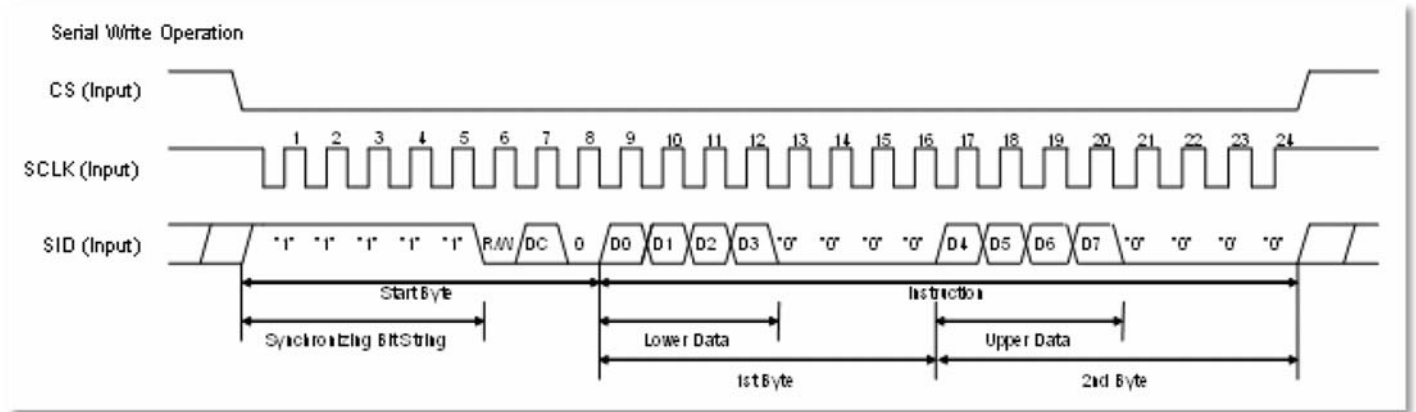

A busy check is not necessary at all. Clock rate may be up to 1 MHz. Data transmission is based on SPI mode 3, MSB first. For more details please refer to the controllers data sheet SSD1311.

DATA TRANSFER I²C

The I²C mode provides a bi-directional data transmission: That means that data can be written and read. Because SA0 is internally set to GND, the I²C address is 0x78 (0x3C). The clock rate may be up to 400 KHz. Please make sure when defining the pull-up resistors that the internal resistance of the display is 600..1000 Ω. This affects the low level when reading data and ACK bit.

Attention: When reading data, after the command for page- or column address there need to be a dummy read (discard the first byte).

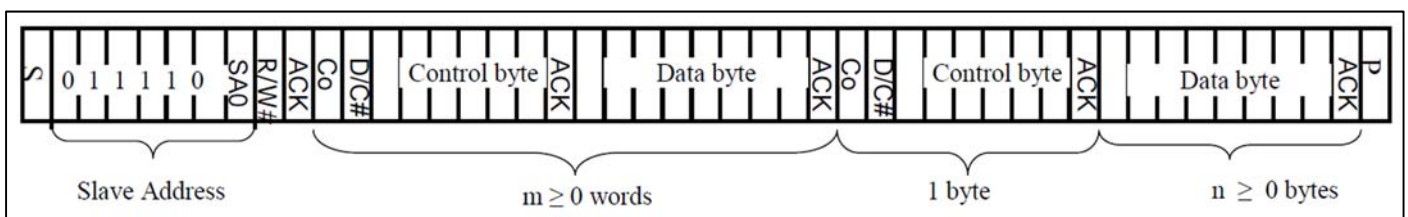

Control byte: C₀ (Continuation bit) = 0 → Display data do follow; 1 → refer D/C bit.

COMMAND TABLE (ABSTRACT)

This is a collection of the most important commands. The data sheet SSD1311 provides the full list plus a detailed description.

1. Fundamental Command Set															
Command	IS	RE	SD	Instruction Code										Description	
				D/C#	R/W# (WR#)	D7	D6	D5	D4	D3	D2	D1	D0		
Clear Display	X	X	0	0	0	0	0	0	0	0	0	0	0	1	Write "20H" to DDRAM and set DDRAM address to "00H" from AC.
Return Home	X	0	0	0	0	0	0	0	0	0	0	0	1	*	Set DDRAM address to "00H" from AC and return cursor to its original position if shifted. The contents of DDRAM are not changed.
Entry Mode Set	X	0	0	0	0	0	0	0	0	0	0	1	I/D	S	Assign cursor / blink moving direction with DDRAM address. I/D = "1": cursor/ blink moves to right and DDRAM address is increased by 1 (POR) I/D = "0": cursor/ blink moves to left and DDRAM address is decreased by 1 Assign display shift with DDRAM address. S = "1": make display shift of the enabled lines by the DS4 to DS1 bits in the shift enable instruction. Left/ right direction depends on I/D bit selection. S = "0": display shift disable (POR)
															X
Display ON / OFF Control	X	0	0	0	0	0	0	0	0	0	1	D	C	B	Set display/cursor/blink ON/OFF D = "1": display ON, D = "0": display OFF (POR), C = "1": cursor ON, C = "0": cursor OFF (POR), B = "1": blink ON, B = "0": blink OFF (POR). Note: It is recommended to turn off the cursor and blinking effects when updating internal RAM contents for better visual performance; refer to Section 9.1.4 for details

1. Fundamental Command Set															
Command	IS	RE	SD	Instruction Code										Description	
				D/C#	R/W# (WR#)	D7	D6	D5	D4	D3	D2	D1	D0		
Extended Function Set	X	1	0	0	0	0	0	0	0	0	1	FW	B/W	NW	Assign font width, black/white inverting of cursor, and 4-line display mode control bit. FW = "1": 6-dot font width, FW = "0": 5-dot font width (POR), B/W = "1": black/white inverting of cursor enable, B/W = "0": black/white inverting of cursor disable (POR) NW = "1": 3-line or 4-line display mode (POR) NW = "0": 1-line or 2-line display mode
Cursor or Display Shift	0	0	0	0	0	0	0	0	0	1	S/C	R/L	*	*	Set cursor moving and display shift control bit, and the direction, without changing DDRAM data. S/C = "1": display shift, S/C = "0": cursor shift, R/L = "1": shift to right, R/L = "0": shift to left
Double Height (4-line) / Display-dot shift	0	1	0	0	0	0	0	0	0	1	UD2	UD1	*	DH'	UD2~1: Assign different doubt height format (POR=11b) Refer to Table 9-2 for details DH' = "1": display shift enable DH' = "0": dot scroll enable (POR)
Shift Enable	1	1	0	0	0	0	0	0	0	1	DS4	DS3	DS2	DS1	DS[4:1]=1111b (POR) when DH' = 1b Determine the line for display shift. DS1 = "1/0": 1 st line display shift enable/disable DS2 = "1/0": 2 nd line display shift enable/disable DS3 = "1/0": 3 rd line display shift enable/disable DS4 = "1/0": 4 th line display shift enable/disable.
Scroll Enable	1	1	0	0	0	0	0	0	0	1	HS4	HS3	HS2	HS1	HS[4:1]=1111b (POR) when DH' = 0b Determine the line for horizontal smooth scroll. HS1 = "1/0": 1 st line dot scroll enable/disable HS2 = "1/0": 2 nd line dot scroll enable/disable HS3 = "1/0": 3 rd line dot scroll enable/disable HS4 = "1/0": 4 th line dot scroll enable/disable.

1. Fundamental Command Set														
Command	IS	RE	SD	Instruction Code										Description
				D/C#	R/W# (WR#)	D7	D6	D5	D4	D3	D2	D1	D0	
Function Set	X	0	0	0	0	0	0	1	*	N	DH	RE (0)	IS	Numbers of display line, N when N = "1" (POR): 2-line (NW=0b) / 4-line (NW=1b), when N = "0": 1-line (NW=0b) / 3-line (NW=1b) DH = "1/0": Double height font control for 2-line mode enable/ disable (POR=0) Extension register, RE ("0") Extension register, IS
	X	1	0	0	0	0	0	1	*	N	BE	RE (1)	REV	CGRAM blink enable BE = 1b: CGRAM blink enable BE = 0b: CGRAM blink disable (POR) Extension register, RE ("1") Reverse bit REV = "1": reverse display, REV = "0": normal display (POR)
Set CGRAM address	0	0	0	0	0	0	1	AC5	AC4	AC3	AC2	AC1	AC0	Set CGRAM address in address counter. (POR=00 0000)
Set DDRAM Address	X	0	0	0	0	1	AC6	AC5	AC4	AC3	AC2	AC1	AC0	Set DDRAM address in address counter. (POR=000 0000)
Set Scroll Quantity	X	1	0	0	0	1	*	SQ5	SQ4	SQ3	SQ2	SQ1	SQ0	Set the quantity of horizontal dot scroll. (POR=00 0000) Valid up to SQ[5:0] = 110000b
Read Busy Flag and Address/ Part ID	X	X	0	0	1	BF	AC6 / ID6	AC5 / ID5	AC4 / ID4	AC3 / ID3	AC2 / ID2	AC1 / ID1	AC0 / ID0	Can be known whether during internal operation or not by reading BF. The contents of address counter or the part ID can also be read. When it is read the first time, the address counter can be read. When it is read the second time, the part ID can be read. BF = "1": busy state BF = "0": ready state
Write data	X	X	0	1	0	D7	D6	D5	D4	D3	D2	D1	D0	Write data into internal RAM (DDRAM / CGRAM).
Read data	X	X	0	1	1	D7	D6	D5	D4	D3	D2	D1	D0	Read data from internal RAM (DDRAM / CGRAM).

Notes

(1) POR stands for Power On Reset Values.

(2) "*" and "X" stand for "Don't care".

The complete data sheet for the controller SSD1311 is available at our website under
<http://www.lcd-module.de/fileadmin/eng/pdf/zubehoer/ssd1311.pdf>.

3 CHARACTER SETS BUILT-IN

ROM A																ROM B																ROM C															
0x00	0x01	0x02	0x03	0x04	0x05	0x06	0x07	0x08	0x09	0x0A	0x0B	0x0C	0x0D	0x0E	0x0F	0x10	0x11	0x12	0x13	0x14	0x15	0x16	0x17	0x18	0x19	0x1A	0x1B	0x1C	0x1D	0x1E	0x20	0x21	0x22	0x23	0x24	0x25	0x26	0x27	0x28	0x29	0x2A	0x2B	0x2C	0x2D	0x2E	0x2F	
[Grid of ROM A characters]																[Grid of ROM B characters]																[Grid of ROM C characters]															

INITIALISATION EXAMPLE

```

void init_OLEDM204(void)
{
    command(0x3A);           //FunctionSet: N=1 BE=0 RE=1 IS=0
    command(0x09);           //4-line mode
    command(0x05);           //View 0°
    command(0x1C);           //FunctionSet: N=1 DH=0 RE=0 IS=0
    command(0x3C);
    command(0x3A);           //FunctionSet: N=1 BE=0 RE=1 IS=0
    command(0x72);           //ROM Selection (RE muss 1 sein)
    data(0x00);              //ROM A
    command(0x3C);           //FunctionSet: N=1 DH=0 RE=0 IS=0
    command(0x0C);           //Display cursor on
    command(0x01);           //Clear display
}
    
```

ACCESSORY: SOCKET EA FL-10P

Using a 10-pin socket makes the display replaceable and adapts the height. Those socket may also be soldered automatically by wave soldering or reflow process. Each display requires 2 pcs.

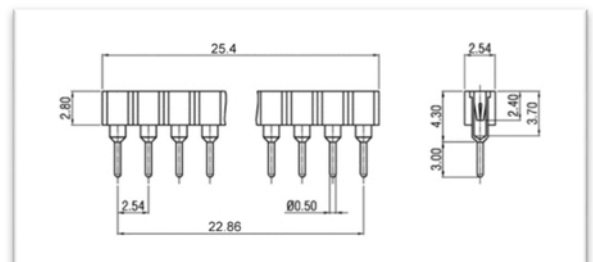

ELECTRICAL SPECIFICATION

Unless otherwise specified, VSS = 0V, VDD = 1.8 - 3.3V (Ta = 25°C)

Value	Condition	min	typ	max	Unit
Operating Temperature		-40		+80	°C
Storage Temperature		-40		+80	°C
Storage Humidity	<40°C			90	%RH
Operating Voltage VDD logic supply	3.3V Design	2.4	3.3	3.6	V
	5V Design	4.4	5.0	5.5	V
Operating Voltage VCC OLED supply			12.0	13.0	V
High Logic input level		0.8 x VDDIO			V
Low Logic input level				0.2 x VDDIO	V
High Logic output level		0.9 x VDDIO			V
Low Logic output level				0.1 x VDDIO	
Power Supply VCC ¹⁾	Empty		0,4		mA
	Demo content ³⁾		3		mA
	Block Character		12		mA
Power Supply VDD ²⁾	Empty		2.5		mA
	Demo content ³⁾		18		mA
	Block Character		23		mA

¹⁾ VCC=12V, externally generated. Initialization 0x81,0xFF / 0xDB,0x20

²⁾ VCC internally generated, VDD=3.3V. Initialization 0x8D, 0x95 / 0x81,0xFF / 0xD5,0x40 / 0xD9,0x44 / 0xDB,0x20

³⁾ Demo content:

* EA OLEDM204-LGA *
 * 4x20 / SPI / I2C *
 * -40..+80°C *
 * 3 fonts+European *

OPTICAL DATA

Item	Symbol	Condition	min	typ	max	Unit
View Angle	(V)θ	CR≥2000	160	170		deg
	(H)φ	CR≥2000	160	170		deg
Contrast Ratio	CR	Dark Room	2000:1			
Response Time	T rise			10		µs
	T fall			10		µs
Luminance	L	-6GGA / -6LGA	80	100		cd/m ²
CIE 1931 x(Yellow)		Dark Room	0.45	0.47	0.49	
CIE 1931 y(Yellow)		Dark Room	0.48	0.50	0.52	

DIMENSION EA OLEDM204

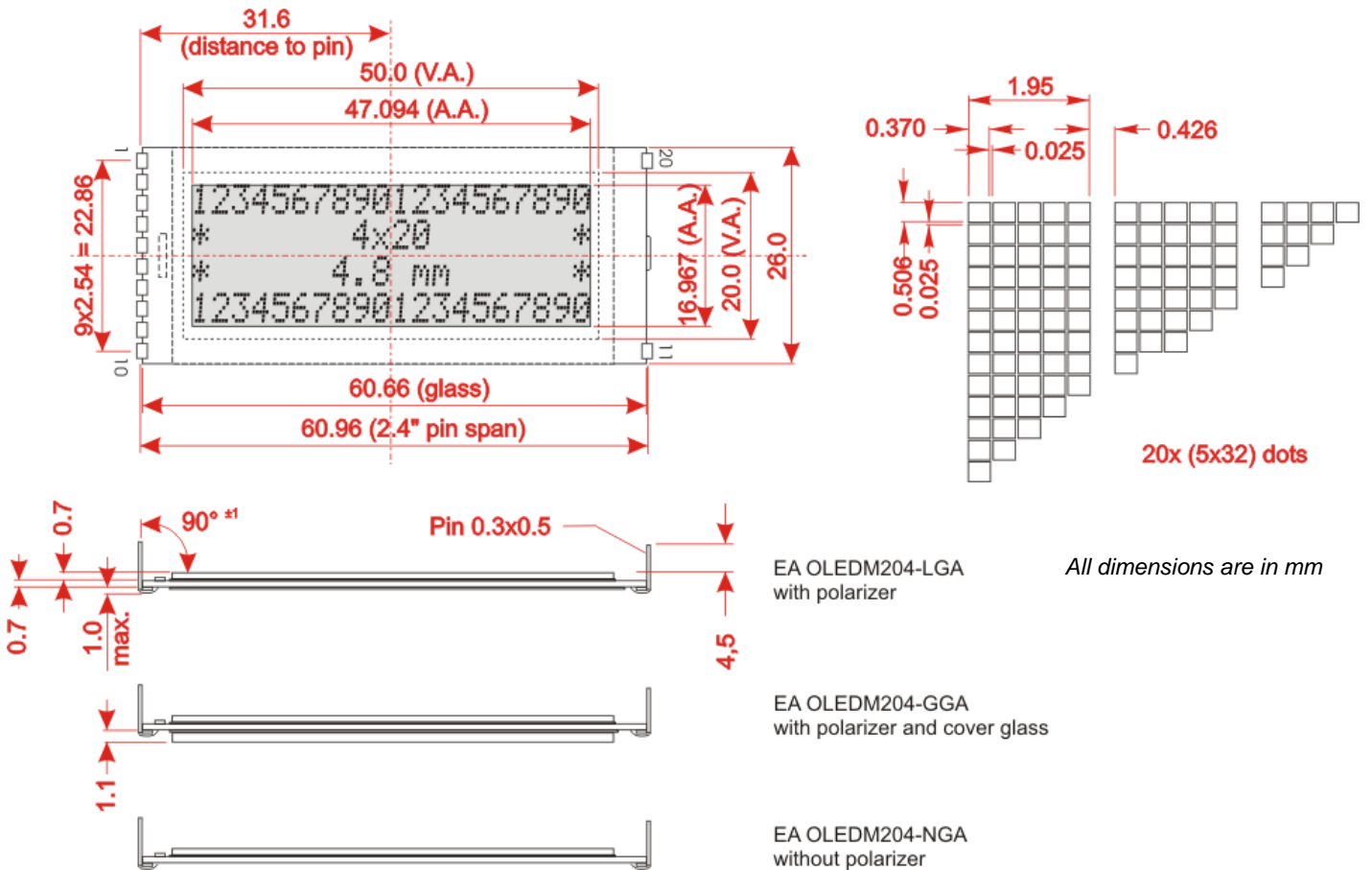

PINOUT

Pin	Symbol	Description	Pin	Symbol	Description
1	VSS	Ground	11	IREF	Segment current reference
2	REGVDD	Internal 3.3V regulator	12	RES	Reset (active low)
3	VDD	3.3 V power supply			
4	VDDIO	Logic power supply			
5	CLK/SCL	Serial Clock			
6	MOSI/SDAin	Data in			
7	MISO/SDAout	Data out			
8	VCOMH	COM signal			
9	VCC	OLED driving voltage	19	CS	Chip Select (active low)
10	VLSS	Analog ground	20	BS1	L = 4-Wire SPI H = I ² C Interface

Note:

- OLED displays are generally not suited for wave or reflow soldering. Temperatures of over 80°C can cause lasting damage.
- The surfaces of the displays are protected from scratching by self-adhesive protective foil. Please remove before mounting
- OLED are generally designed for indoor application. When be used outside they need to be protected against sunlight (UV radiation) and humidity, water and dust.