

REVISION RECORD

REV	ECN	DESCRIPTION	DRFT	DATE
-----	-----	-------------	------	------

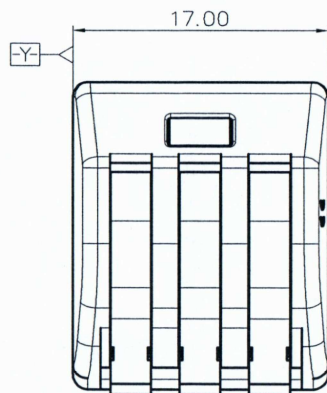

仅供参考图
 签字: *[Signature]*
 日期: 9/13/16

NOTES1:

- UL Standard
- 1.Rated voltage/current : 600V / 20A
- 2.Wire range : 28~12AWG
- IEC Standard
- 1.Rated voltage/current : 400V / 32A
- 2.Wire range : 0.2~2.5mm²

NOTES2:

- 1.Dimension shall be interpreted per ASME Y14.5-2009
- 2.Pitch : 4.61mm, Poles : N=3P
- 3.Stripping length : 9~10mm
- 4.Withstanding voltage : AC2500V/1Min
- 5.Operating temperature : -40°C~+105°C
- 6.Undimensioned tolerances:

Pitch range in mm		Nominal dimension range in mm						-	∠
TO	Over	TO	Over	TO	Over	TO	Over	0.1/10	
6	10	24	30	60	100	150		<	
±0.15	±0.20	±0.30	±0.30	±0.50	±0.70	±1.00	±1.30	±2'	

7.RoHS Compliance

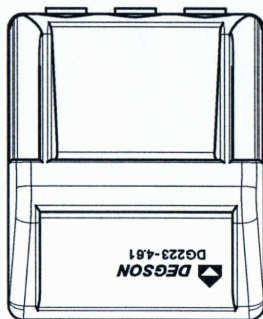
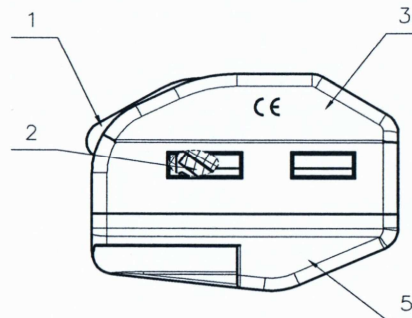
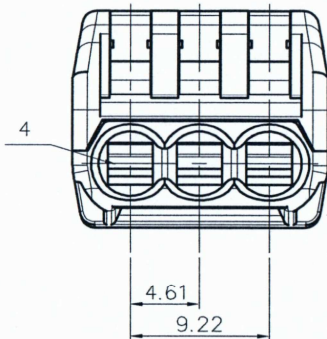
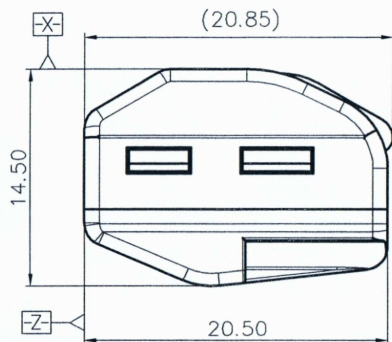

ITEM	NAME OF PART	MATERIAL	NOTES
5	Housing	PA66	UL94V-0
4	Spring	Stainless steel	
3	Cover	PA66	UL94V-0
2	Current carrier	Copper alloy	Sn Plated
1	Button	POM	UL94HB

DETACHED LISTS	PART NO.: /		宁波高松电子有限公司 NINGBO DEGSON ELECTRICAL CO., LTD	
	APPD: <i>X/mg/12/16</i>	NAME: DG223-4.61-03P-1Y-00A(H)		
	CHKD: <i>peny/9/13/16</i>	TITLE: CUSTOMER DRAWING		
	DRFT: MEK 07/08/16	DRAWING NO.: DG223-4.61-C02	REV	D0-1
		DRAWING NO.: DG223-4.61-C02	SHEET	1/1
THIRD ANGLE PROJECTION		MM (INCH)	DO NOT SCALE DRAWING	SCALE 1:1