

| REVISION RECORD | | | | |
|-----------------|-----|-------------|------|------|
| REV | ECN | DESCRIPTION | DRFT | DATE |

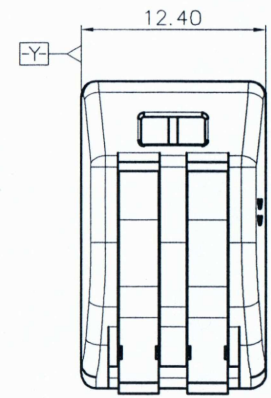

仅供参考图
 签字: *何/李/张*
 日期: 9/13/16

NOTES1:
 UL Standard
 1.Rated voltage/current : 600V / 20A
 2.Wire range : 28~12AWG
 IEC Standard
 1.Rated voltage/current : 400V / 32A
 2.Wire range : 0.2~2.5mm²

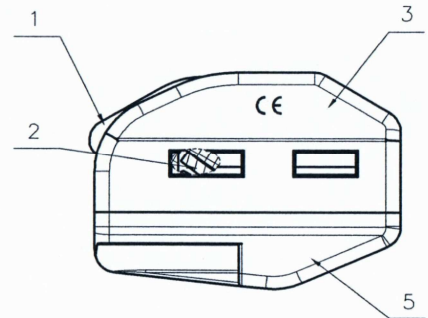
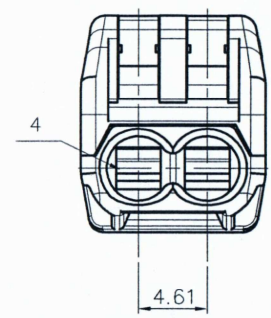
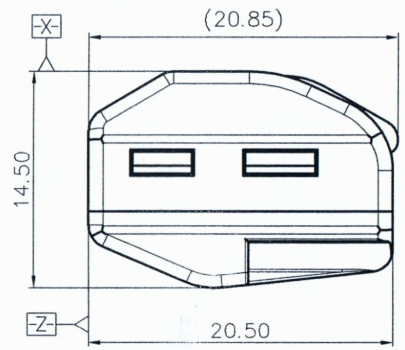

NOTES2:
 1.Dimension shall be interpreted per ASME Y14.5-2009
 2.Pitch : 4.61mm, Poles : N=2P
 3.Stripping length : 9~10mm
 4.Withstanding voltage : AC2500V/1Min
 5.Operating temperature : -40°C~+105°C
 6.Undimensioned tolerances:

| Pitch range in mm | | Nominal dimension range in mm | | | | | | |
|-------------------|------|-------------------------------|------|----|------|-----|-------|--------|
| TO | Over | TO | Over | TO | Over | TO | Over | |
| 6 | 10 | 10 | 24 | 30 | 60 | 100 | 150 | 0.1/10 |
| | | | | | | | < | |
| | | | | | | | ±0.15 | ±2 |

7.RoHS Compliance

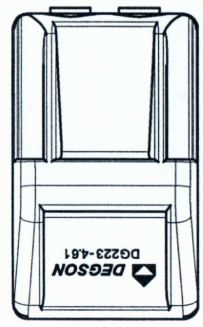

| ITEM | NAME OF PART | MATERIAL | NOTES |
|------|-----------------|-----------------|-----------|
| 5 | Housing | PA66 | UL94V-0 |
| 4 | Spring | Stainless steel | |
| 3 | Cover | PA66 | UL94V-0 |
| 2 | Current carrier | Copper alloy | Sn Plated |
| 1 | Button | POM | UL94HB |

| | | | | |
|------------------------|----------------------------|---|------------|------------|
| DETACHED LISTS | PART NO.: / | 宁波高松电子有限公司 NINGBO DEGSON ELECTRICAL CO., LTD | | |
| | APPD: <i>Xiang 9/13/16</i> | NAME: DG223-4.61-02P-1Y-00A(H) | | |
| | CHKD: <i>perai 9/13/16</i> | TITLE: CUSTOMER DRAWING | | |
| | DRFT: MEK 07/08/16 | REV: D0-1 | SHEET: 1/1 | SCALE: 1:1 |
| THIRD ANGLE PROJECTION | | DRAWING NO.: DG223-4.61-C01 DO NOT SCALE DRAWING | | |

H
G
F
E
D
C
B
A

H
G
F
E
D
C
B
A