

DF9 Series

1mm Pitch SMT Board-to-Board Connectors (Standard Interface Connector Compliant with VESA FPD1-1)



P = 1.0 mm



Mis-Insert Prevention



Friction-Lock

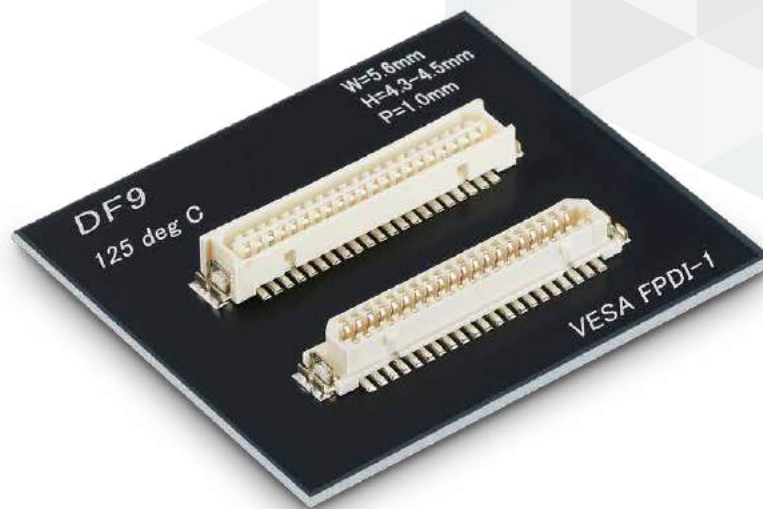

Features

1. Compliant with VESA FPDI-1 Interface Connector Standard

The 31 and 41pos. connectors conform to the FPDI-1 standard connector specifications for flat panel display interfaces by the U.S. VESA.

VESA :Video Electronics Standards Association
FPDI-1:Flat Panel Display Interface

2. Complete Mis-insertion Prevention

The trapezoidal mating port prevents mis-insertion at a compact size.

3. Friction Lock

Friction lock provides reliable insertion and removal.

4. Smooth Insertion and Removal

Contact portion is made of material that does not have a fractured surface for smooth insertion and removal.

5. Two Standard Types of Plating Available

Plating is available in both tin and gold for selection based on cost and application conditions.

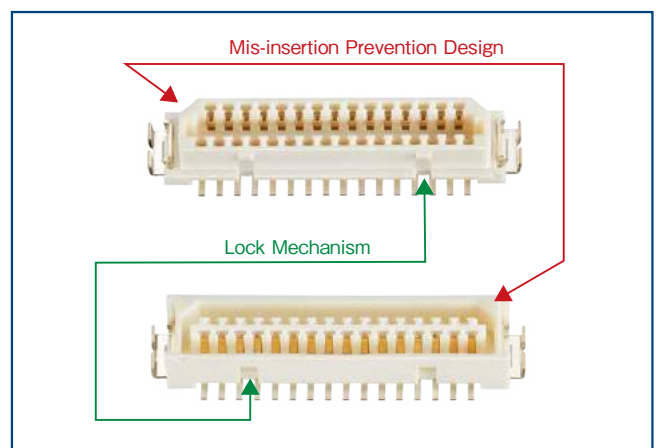

Product Specifications

Rated Current	0.5A	Operating Temperature (Note 1)	-45 to +125°C
Rated Voltage	150V AC	Operating Humidity Range	40 to 80%
		Storage Temperature (Note 2)	-10 to +60°C
		Storage Humidity Range (Note 2)	40 to 70%

Items	Specifications	Conditions
Contact Resistance	50m Ω Max.	Measured at 100mA
Insulation Resistance	500M Ω Min.	Measured at 100V DC
Withstanding Voltage	No flashover or dielectric breakdown	250V AC for 1 min.
Mating Durability	Contact Resistance : 50m Ω Max.	Tin Plating : 30 times Gold Plating : 100 times
Vibration Resistance	No electrical discontinuity of 1 μ s Min.	Frequency : 10 to 55Hz, Half Amplitude of 0.75mm, 2 hours in each of the 3 directions
Humidity Resistance	Contact Resistance : 50m Ω Max. Insulation Resistance : 500M Ω Min.	Left for 96 hours at a temperature of 40 ± 2°C and a humidity range from 90 to 95%
Temperature Cycle	Contact Resistance : 50m Ω Max. Insulation Resistance : 500M Ω Min.	Temperature : -65°C → +5 to +35°C → +125°C → +5 to +35°C Time : 30 min. → 10 min. → 30 min. → 10 min. 5 cycles
Solder Heat Resistance	No dissolution or resin melting that will affect performance.	Reflow : At recommended temperature profile Hand Solder : Solder iron temperature of 380°C for 5 seconds Max.

Note 1 : Includes the temperature rise due to current flow.

Note 2 : Storage refers to long-term storage of unused items before they are mounted on the PCB.

Operating temperature and humidity range apply when the product is not powered after PCB mounting and when temporarily stored during transportation.

Materials / Finish

Item	Component	Material	Finish	Remarks
Receptacle Header	Insulator	Polyamide Resin	Beige (Natural)	UL94V-0
	Contact	Phosphor Bronze	Tin Plating or Gold Plating	-
	Retention Tab	Brass	Tin Plating	-

Note : The gold plated product contact area is plated with gold, and lead plated with tin.

Product Number Structure

● Receptacle/Header

Refer to the chart below when determining the product specifications from the product number.
Please select from the product numbers listed in this catalog when placing orders.

DF9 # - # S - 1 V (##)

① ② ③ ④ ⑤ ⑥ ⑦

① Series Name	DF9	⑤ Contact Pitch	1mm
② Type	Blank : With Retention Tab and Boss B : With Retention Tab and Without Boss	⑥ Terminal Design	V : Straight SMT
③ No. of Contacts	9-25, 31, 41, 51	⑦ Plating Specifications and Packaging	(32) : Tin Plating, Embossed Packaging (69) : Gold Plating, Embossed Packaging
④ Connector Type	S : Receptacle P : Header		

Receptacle (With Retention Tab and Boss)

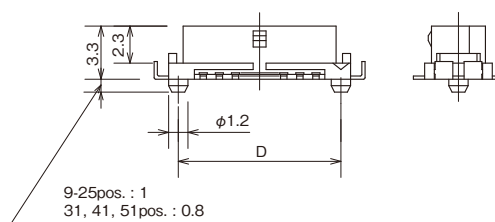
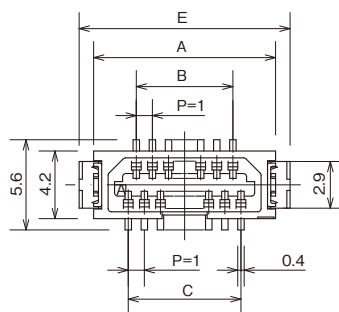
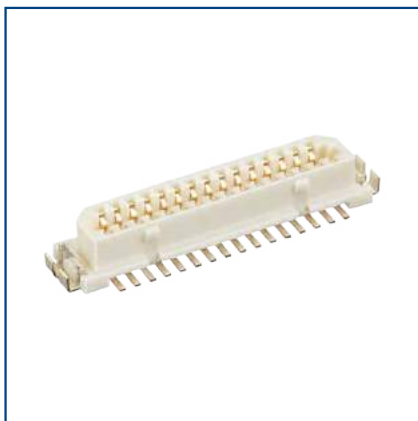

Unit : mm

Part No.	HRS No.	No. of Pos.	A	B	C	D	E	Tin Plating	Gold Plating	RoHS	Purchase Unit
DF9-9S-1V(##)	CL0540-0054-0-##	9	8.3	3.0	4.0	7.1	10.1	Yes	Yes	Yes	1,000pcs per reel
DF9-11S-1V(##)	CL0540-0055-2-##	11	9.3	4.0	5.0	8.1	11.1	Yes	Yes		
DF9-13S-1V(##)	CL0540-0056-5-##	13	10.3	5.0	6.0	9.1	12.1	Yes	Yes		
DF9-15S-1V(##)	CL0540-0057-8-##	15	11.3	6.0	7.0	10.1	13.1	Yes	Yes		
DF9-17S-1V(##)	CL0540-0058-0-##	17	12.3	7.0	8.0	11.1	14.1	Yes	Yes		
DF9-19S-1V(##)	CL0540-0059-3-##	19	13.3	8.0	9.0	12.1	15.1	Yes	Yes		
DF9-21S-1V(##)	CL0540-0060-2-##	21	14.3	9.0	10.0	13.1	16.1	Yes	Yes		
DF9-23S-1V(##)	CL0540-0061-5-##	23	15.3	10.0	11.0	14.1	17.1	Yes	Yes		
DF9-25S-1V(##)	CL0540-0062-8-##	25	16.3	11.0	12.0	15.1	18.1	Yes	Yes		
DF9-31S-1V(##)	CL0540-0063-0-##	31	19.3	14.0	15.0	18.1	21.1	Yes	Yes		
DF9-41S-1V(##)	CL0540-0213-1-##	41	24.3	19.0	20.0	23.1	26.1	Yes	Yes		
DF9-51S-1V(##)	CL0540-0064-3-##	51	29.3	24.0	25.0	28.1	31.1	-	Yes		

[Specification No.] -##.(##)

(32) : Tin Plating, With Boss

(69) : Gold Plating, With Boss

(Note 1) With pick & place tape

(Note 2) Please contact a Hirose representative for requests on Gold plating or Tin plating pin count variations that have not been released.

Receptacle (With Retention Tab and Without Boss)

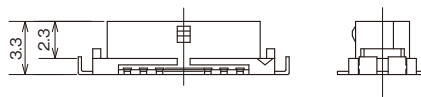
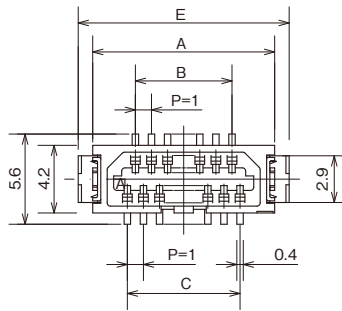
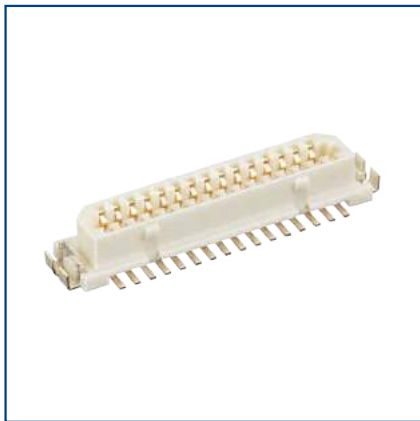

Unit : mm

Part No.	HRS No.	No. of Pos.	A	B	C	D	E	Tin Plating	Gold Plating	RoHS	Purchase Unit
DF9B-9S-1V(##)	CL0540-0125-6-##	9	8.3	3.0	4.0	-	10.1	Yes	Yes	Yes	1,000pcs per reel
DF9B-11S-1V(##)	CL0540-0126-9-##	11	9.3	4.0	5.0	-	11.1	Yes	-		
DF9B-13S-1V(##)	CL0540-0127-1-##	13	10.3	5.0	6.0	-	12.1	Yes	Yes		
DF9B-15S-1V(##)	CL0540-0128-4-##	15	11.3	6.0	7.0	-	13.1	Yes	Yes		
DF9B-17S-1V(##)	CL0540-0129-7-##	17	12.3	7.0	8.0	-	14.1	-	Yes		
DF9B-19S-1V(##)	CL0540-0247-3-##	19	13.3	8.0	9.0	-	15.1	-	Yes		
DF9B-21S-1V(##)	CL0540-0131-9-##	21	14.3	9.0	10.0	-	16.1	Yes	Yes		
DF9B-23S-1V(##)	CL0540-0132-1-##	23	15.3	10.0	11.0	-	17.1	Yes	-		
DF9B-25S-1V(##)	CL0540-0133-4-##	25	16.3	11.0	12.0	-	18.1	Yes	-		
DF9B-31S-1V(##)	CL0540-0143-8-##	31	19.3	14.0	15.0	-	21.1	Yes	Yes		
DF9B-41S-1V(##)	CL0540-0216-0-##	41	24.3	19.0	20.0	-	26.1	Yes	Yes		
DF9B-51S-1V(##)	CL0540-0145-3-##	51	29.3	24.0	25.0	-	31.1	-	Yes		

[Specification No.] -##,(##)
 (32) : Tin Plating, With Boss
 (69) : Gold Plating, With Boss

(Note 1) With pick & place tape

(Note 2) Please contact a Hirose representative for requests on Gold plating or Tin plating pin count variations that have not been released.

Header (With Retention Tab and Boss)

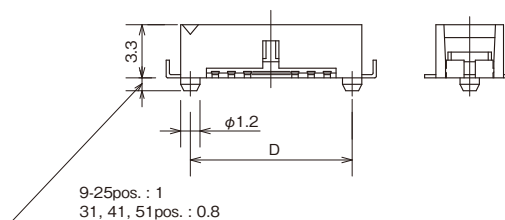
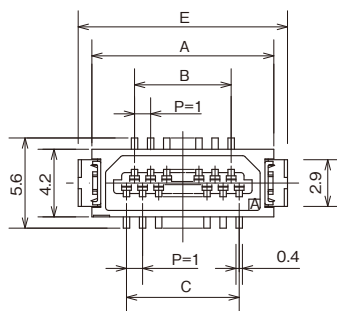
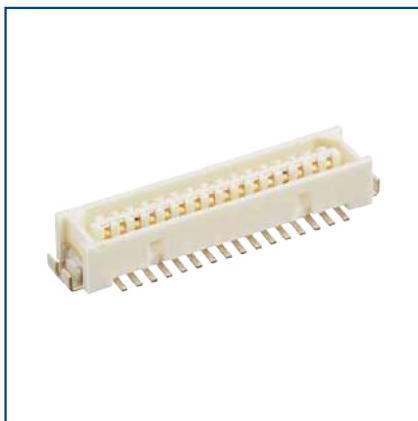

Unit : mm

Part No.	HRS No.	No. of Pos.	A	B	C	D	E	Tin Plating	Gold Plating	RoHS	Purchase Unit
DF9-9P-1V(##)	CL0540-0066-9-##	9	8.3	3.0	4.0	7.1	10.1	Yes	Yes	Yes	1,000pcs per reel
DF9-11P-1V(##)	CL0540-0067-1-##	11	9.3	4.0	5.0	8.1	11.1	Yes	Yes		
DF9-13P-1V(##)	CL0540-0068-4-##	13	10.3	5.0	6.0	9.1	12.1	Yes	Yes		
DF9-15P-1V(##)	CL0540-0069-7-##	15	11.3	6.0	7.0	10.1	13.1	Yes	Yes		
DF9-17P-1V(##)	CL0540-0070-6-##	17	12.3	7.0	8.0	11.1	14.1	Yes	Yes		
DF9-19P-1V(##)	CL0540-0071-9-##	19	13.3	8.0	9.0	12.1	15.1	Yes	Yes		
DF9-21P-1V(##)	CL0540-0072-1-##	21	14.3	9.0	10.0	13.1	16.1	Yes	Yes		
DF9-23P-1V(##)	CL0540-0073-4-##	23	15.3	10.0	11.0	14.1	17.1	Yes	Yes		
DF9-25P-1V(##)	CL0540-0074-7-##	25	16.3	11.0	12.0	15.1	18.1	Yes	Yes		
DF9-31P-1V(##)	CL0540-0075-0-##	31	19.3	14.0	15.0	18.1	21.1	Yes	Yes		
DF9-41P-1V(##)	CL0540-0214-4-##	41	24.3	19.0	20.0	23.1	26.1	Yes	Yes		
DF9-51P-1V(##)	CL0540-0088-1-##	51	29.3	24.0	25.0	28.1	31.1	-	Yes		

[Specification No.] -##.(##)

(32) : Tin Plating, With Boss

(69) : Gold Plating, With Boss

(Note 1) With pick & place tape

(Note 2) Please contact a Hirose representative for requests on Gold plating or Tin plating pin count variations that have not been released.

Header (With Retention Tab and Without Boss)

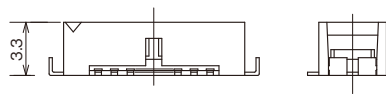
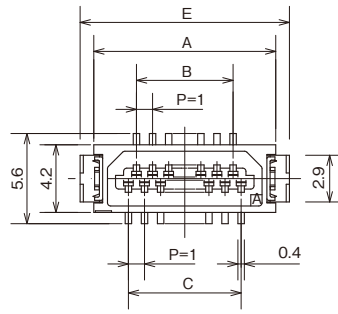
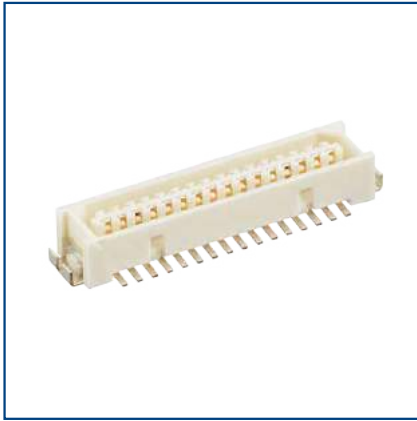

Unit : mm

Part No.	HRS No.	No. of Pos.	A	B	C	D	E	Tin Plating	Gold Plating	RoHS	Purchase Unit
DF9B-9P-1V(##)	CL0540-0134-7-##	9	8.3	3.0	4.0	-	10.1	Yes	Yes	Yes	1,000pcs per reel
DF9B-11P-1V(##)	CL0540-0135-0-##	11	9.3	4.0	5.0	-	11.1	Yes	Yes		
DF9B-13P-1V(##)	CL0540-0136-2-##	13	10.3	5.0	6.0	-	12.1	Yes	-		
DF9B-15P-1V(##)	CL0540-0137-5-##	15	11.3	6.0	7.0	-	13.1	Yes	Yes		
DF9B-17P-1V(##)	CL0540-0138-8-##	17	12.3	7.0	8.0	-	14.1	Yes	Yes		
DF9B-19P-1V(##)	CL0540-0248-6-##	19	13.3	8.0	9.0	-	15.1	Yes	Yes		
DF9B-21P-1V(##)	CL0540-0140-0-##	21	14.3	9.0	10.0	-	16.1	Yes	Yes		
DF9B-23P-1V(##)	CL0540-0141-2-##	23	15.3	10.0	11.0	-	17.1	Yes	-		
DF9B-25P-1V(##)	CL0540-0142-5-##	25	16.3	11.0	12.0	-	18.1	Yes	-		
DF9B-31P-1V(##)	CL0540-0144-0-##	31	19.3	14.0	15.0	-	21.1	Yes	Yes		
DF9B-41P-1V(##)	CL0540-0221-0-##	41	24.3	19.0	20.0	-	26.1	Yes	Yes		
DF9B-51P-1V(##)	CL0540-0146-6-##	51	29.3	24.0	25.0	-	31.1	-	Yes		

[Specification No.] -##,(##)

(32) : Tin Plating, With Boss

(69) : Gold Plating, With Boss

(Note 1) With pick & place tape

(Note 2) Please contact a Hirose representative for requests on Gold plating or Tin plating pin count variations that have not been released.

Recommended PCB Layout

● With Retention Tab and Boss

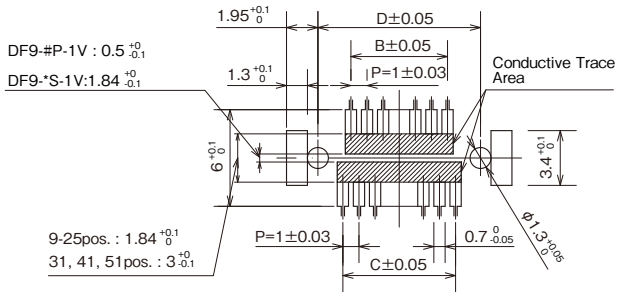

● Retention Tab, Without Boss

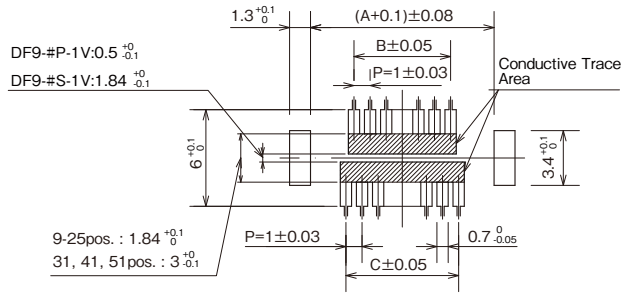

(Note 1) If a pattern is included in the shaded area and not treated with resist, it could touch the connector contact.
 (Note 2) Please refer to each product size pattern for the universal size on the above patterns (A, B, C, D...).

Application Pattern

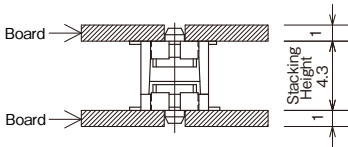

(Note) Solder paste thickness is not included in the 4.3mm distance between boards in the figure.

■ Embossed Tape Dimensions (JIS-C-0806 Compliant)

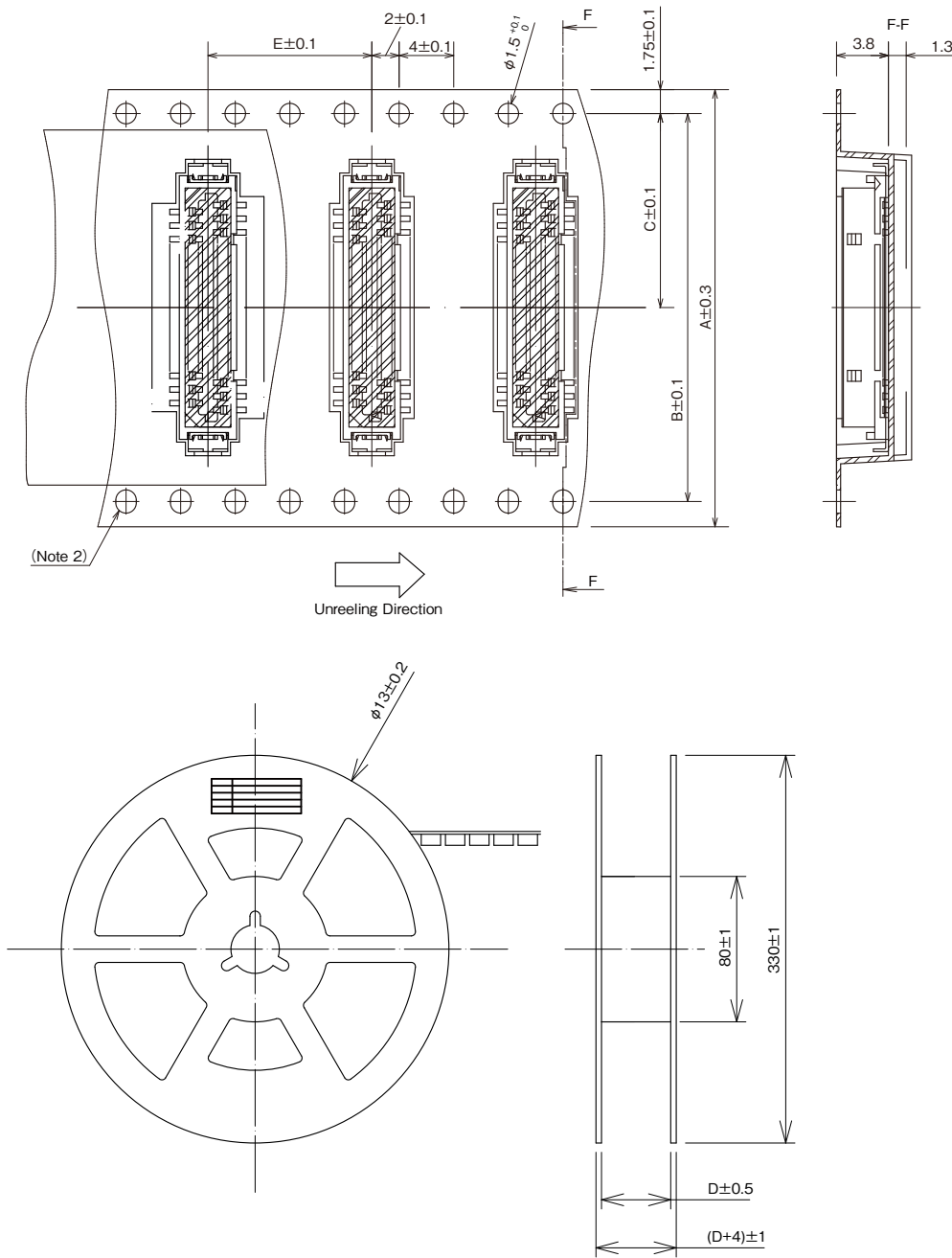

Unit : mm

Part No.	No. of Pos.	A	B	C	D	E
DF9#-#S/P-1V	9-21	24	-	11.5	25.5	12
	23-31	32	28.4	14.2	33.5	12
	41, 51	44	40.4	20.2	45.5	12

(Note 1) The pocket design may vary depending on the pin count.

(Note 2) The hole of the carrier tape will be only one side if A is less than 32mm.

Precautions

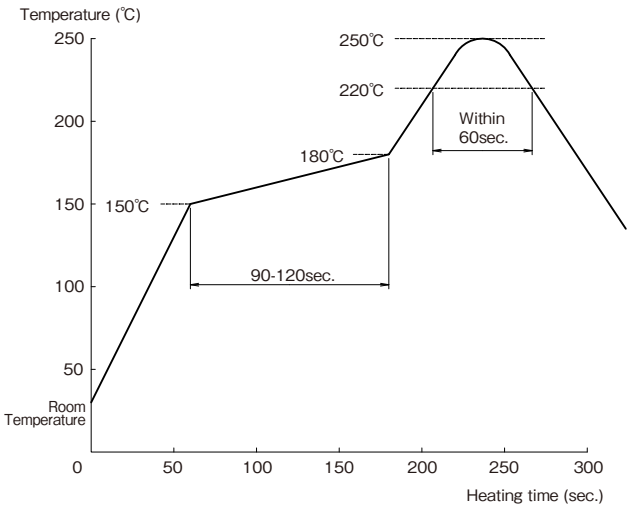
Recommended Temperature Profile	<p>DF9 Series Lead-free Temperature Profile</p>  <p>【Conditions】</p> <ol style="list-style-type: none"> 1. Peak Temperature 250°C 2. Heating Section: 220°C Min. within 60 seconds 3. Preheat Section: 150 to 180°C for 90 to 120 seconds. 4. No. of times: Within 2 times <p>(Note 1) Up to 2 cycles of reflow soldering are possible under the same conditions, provided that there is a return to normal temperature between the first and second cycle.</p> <p>(Note 2) Temperature indicates the surface temperature of the connector lead.</p>
Recommended Manual Soldering Condition	370 ± 10°C for 3 seconds Max.
Recommended Metal Mask Thickness	0.15mm
Board Warpage	Max. 0.03mm in the connector center area, based on both connector edges
Cleaning Conditions	Refer to "User Guide for Wire-to-Board Connector".
Cautions	<ol style="list-style-type: none"> 1. Avoid supporting the PCB only with the connectors. Support it by other means such as bolts, screws, posts, etc. 2. Be careful when mating/unmating the connector when it is not mounted on the PCB as doing so may cause damage/deformation to contacts. 3. Excessive prying during unmating/mating may result in damage. 4. In the case of hand soldering, please do not apply any flux which could cause flux wicking. 5. This product may have slight color differences due to production lot variability, but this does not affect the performance.

While Taking into Consideration

Specifications mentioned in this catalog are reference values.

When considering to order or use this product, please confirm the Drawing and Product Specifications sheets.

Use an appropriate cable when using the connector in combination with cables.

If considering usage of a non-specified cable, please contact your sales representative.

If assembly process is done by jigs & tools which are not identified by Hirose, assurance will not be given.

If considering usage for below mentioned applications, please contact your sales representative.

In cases where the application will demand a high level of reliability, such as automotive, medical instruments, public infrastructure, aerospace/defense etc. Hirose must review before assurance of reliability can be given.