

DISPLAY Elektronik GmbH

DATA SHEET

TFT MODULE

DEM 268800A VMH-PW-N

2,99“ TFT

Product Specification

Ver.: 3

17.07.2023

1	16.06.2023	New Release.	WYC	LSB
2	29.06.2023	Delete some contents as customer requirement	WYC	LSB
3	17.07.2023	1. Add Item 4.0, 5.0,11.0,15.0 2. Update Item 7.0	WYC	LSB

CONTENTS

1.0	GENERAL SPECIFICATION
2.0	OUTLINE DRAWING
3.0	INTERFACE PIN DESCRIPTION
4.0	BLOCK DIAGRAM
5.0	OPERATING PRINCIPLE & DRIVING METHOD
6.0	ABSOLUTE MAXIMUM RATINGS
7.0	ELECTRICAL CHARACTERISTICS
8.0	ELECTRO-OPTICAL CHARACTERISTICS
9.0	BACKLIGHT SPECIFICATION
10.0	RELIABILITY SPECIFICATION
11.0	QUALITY SPECIFICATION
12.0	ENVIRONMENTAL SPECIFICATION
13.0	GENERAL PRECAUTIONS FOR USING LCD MODULES
14.0	APPENDIX

1.0 GENERAL SPECIFICATION

Item	Contents	Unit
Display Mode	2.99" TFT Transmissive/IPS/Normally Black	-
Module outer dimension	26.96 x 80.08 x 1.68 (Excluded FPC length)	mm
Pixel Size	0.09 x 0.09	mm
Active Area	24.12 x 72.00	mm
Number of Dots	268 x RGB x 800	Dots
Viewing Direction	Free	o'clock
Pixel Arrangement	RGB Vertical Stripe	-
Backlight	LED white backlight	-
Driver IC	ST7701S (Sitronix)	-
Interface Type	MIPI Interface	-
Number Of Colors	16.8 Million	-
Operating Temperature	-20 ~ +70	°C
Storage Temperature	-30 ~ +80	°C

Remarks: Normal operating condition is temperature 15°C ~ 35°C, Humidity 45%~75%RH,
Atmospheric Pressure 86kPa ~ 106kPa.

3.0 INTERFACE PIN DESCRIPTION

Pin No.	Symbol	Pin Description
1	GND	Ground
2	VCC 3.3	Power Supply Voltage
3	IOVCC	Power Supply for the Logic Power and I/O Circuit
4	RESET	Reset Signal Input Pin
5	GND	Ground
6	D1P	MIPI DSI data1+
7	D1N	MIPI DSI data1-
8	GND	Ground
9	CLKP	MIPI DSI CLOCK+
10	CLKN	MIPI DSI CLOCK-
11	GND	Ground
12	D0P	MIPI DSI DATA0+
13	D0N	MIPI DSI DATA0-
14	GND	Ground
15	TE	Tearing Effect Pin
16	LEDA	LED Backlight Anode
17	NC	No Connection
18	LEDK	LED Backlight Cathode
19	NC	No Connection
20	TP-VCC	No Connection
21	TP-RESET	No Connection
22	TP-INT	No Connection
23	TP-SDA	No Connection
24	TP-SCL	No Connection
25	GND	Ground

4.0 BLOCK DIAGRAM

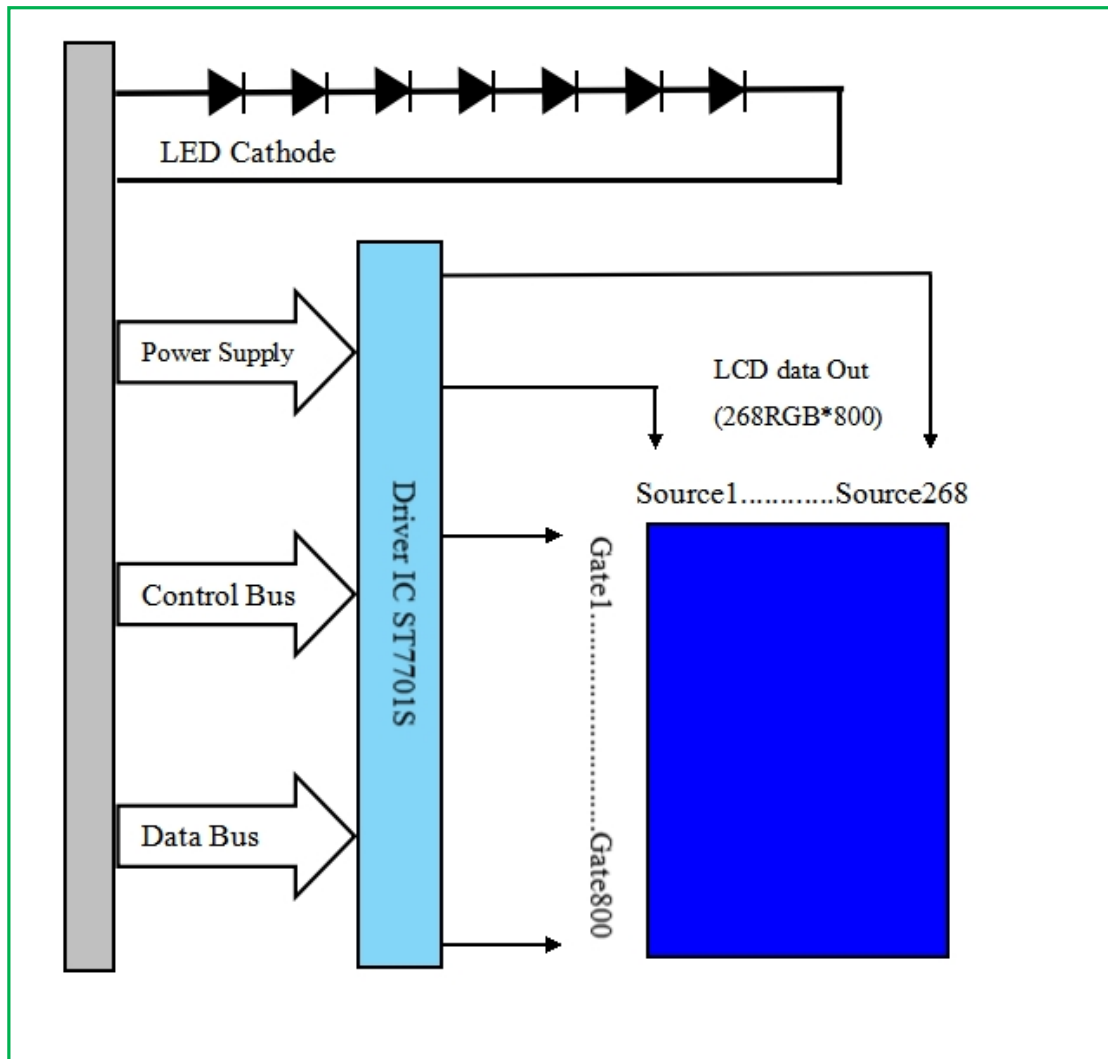

5.0 OPERATING PRINCIPLE & DRIVING METHOD

- 5.1 Please refer to GC9A01 A (V1.0) IC data sheet.
- 5.2 Instruction Description (based on IC spec as stated in 6.1 where the product is designed). This instruction description is for reference only. Customer is encouraged to always refer to the latest IC specification when developing application system platform.
- 5.3 Recommended initial codes

TBD

Notes:

- 1) These initial codes are only for reference, Customer should optimize above setting according to the display pattern and application used.
- 2) Customer is advised to refer to "General Handling Precaution of LCD Modules" section in this product specification regarding the operating precaution of LCD modules, when optimizing the display initialization setting.
- 3) Display Elektronik GmbH will use above initial code for production testing by default. Customer is advised to highlight to Display Elektronik GmbH in case that initial code setting in customer application is different with above initial code. Reason is to ensure Display Elektronik GmbH testing is in-line with customer application as close as possible for good quality control.

5.4 Power On/Off Sequence

VDDI and VDDA can be applied or powered down in any order. During the Power Off sequence, if the LCD is in the Sleep Out mode, VDDA and VDDI must be powered down with minimum 120msec. If the LCD is in the Sleep In mode, VDDA and VDDI can be powered down with minimum 0msec after the RESX is released.

CSX can be applied at any timing or can be permanently grounded. RESX has high priority over CSX.

Notes:

1. There will be no damage to the ST7701SN-1 if the power sequences are not met.
2. There will be no abnormal visible effects on the display panel during the Power On/Off Sequences.
3. There will be no abnormal visible effects on the display between the end of Power On Sequence and before receiving the Sleep Out command, and also between receiving the Sleep In command and the Power Off Sequence.
4. If the RESX line is not steadily held by the host during the Power On Sequence as defined in Sections 9.1 , then it will be necessary to apply the Hardware Reset (RESX) after the completion of the Host Power On Sequence to ensure correct operations. Otherwise, all the functions are not guaranteed.
5. When VDDA is in power off State , the MIPI must set in Ultra Low Power Mode (GND Level).

The power on/off sequence is illustrated below

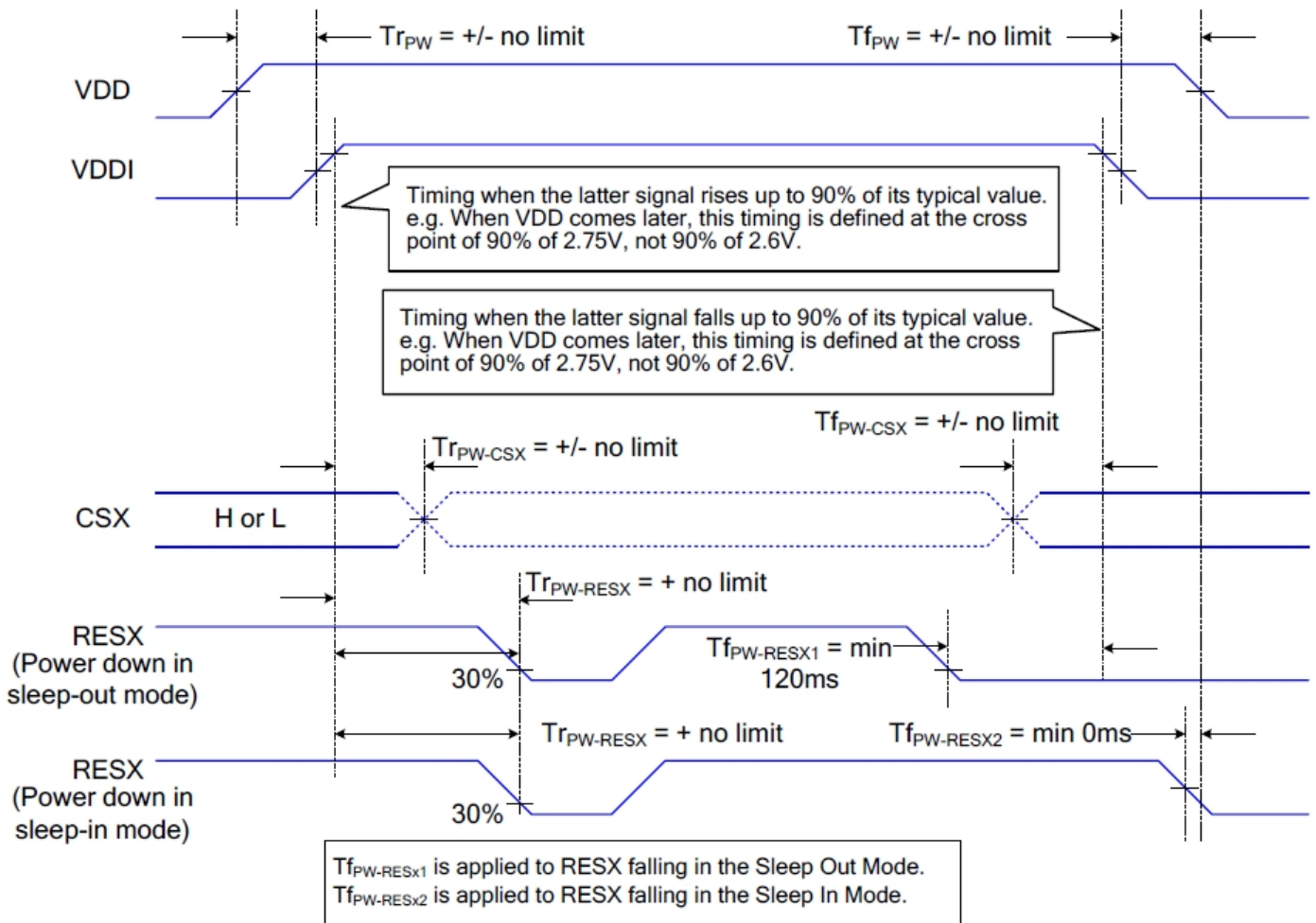

Note5:

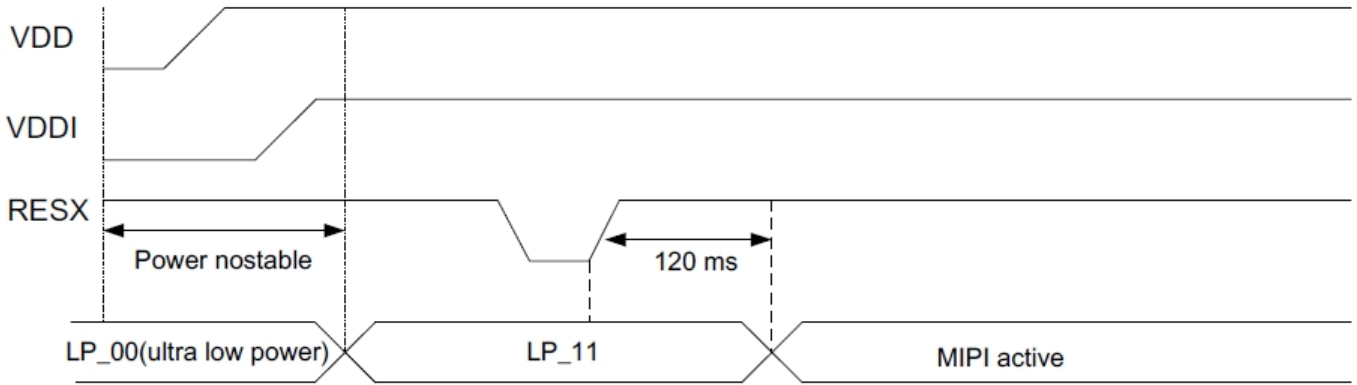

9.1 Uncontrolled Power Off

The uncontrolled power-off means a situation which removed a battery without the controlled power off sequence. It will neither damage the module or the host interface.

If uncontrolled power-off happened, the display will go blank and there will not any visible effect on the display (blank display) and remains blank until "Power On Sequence" powers it up.

5.5 Timing Characteristics

High Speed Mode

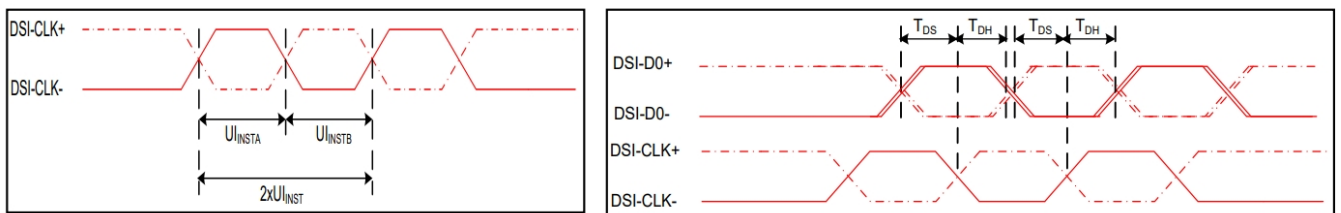

Figure 4 DSI clock channel timing

Figure 5 Rising and falling time on clock and data channel

VDDI=1.8, VDD=2.8, AGND=DGND=0V, Ta=25 °C

Signal	Symbol	Parameter	MIN	MAX	Unit	Description
DSI-CLK+/-	2xUI _{INSTA}	Double UI instantaneous	2.5	25	ns	
DSI-CLK+/-	UI _{INSTA} UI _{INSTB}	UI instantaneous halves	1.25	12.5	ns	UI = UI _{INSTA} = UI _{INSTB}
DSI-Dn+/-	t _{DS}	Data to clock setup time	0.15	-	UI	
DSI-Dn+/-	t _{DH}	Data to clock hold time	0.15	-	UI	

Table 7 Mipi Interface- High Speed Mode Timing Characteristics

Low Power Mode

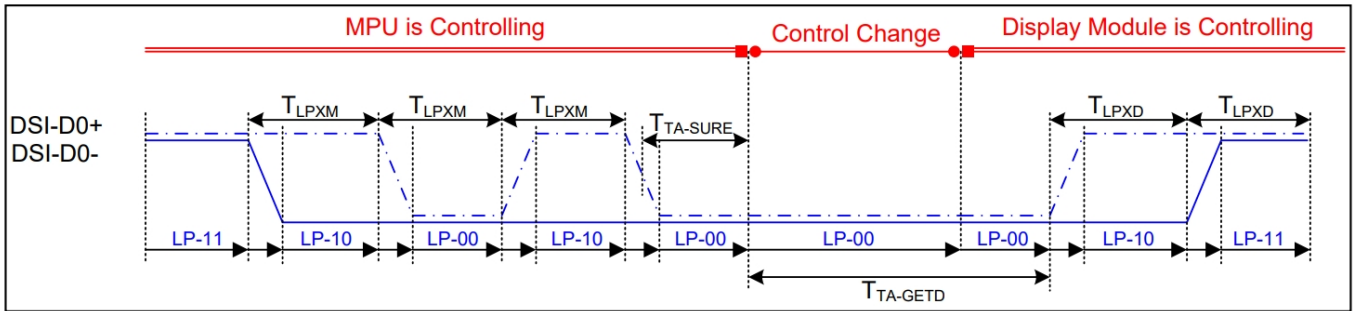

Figure 6 Bus Turnaround (BTA) from display module to MPU Timing

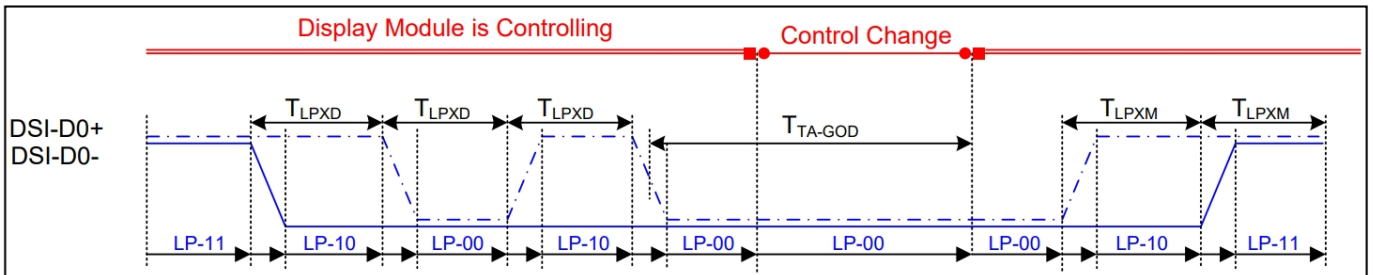

Figure 7 Bus Turnaround (BTA) from MPU to display module Timing

VDDI=1.8, VDD=2.8, AGND=DGND=0V, Ta=25 °C

Signal	Symbol	Parameter	MIN	MAX	Unit	Description
DSI-D0+/-	TLPXM	Length of LP-00,LP-01, LP-10 or LP-11 periods MPU→Display Module	50	75	ns	Input
DSI-D0+/-	TLPXD	Length of LP-00,LP-01, LP-10 or LP-11 periods MPU→Display Module	50	75	ns	Output
DSI-D0+/-	TTA-SURED	Time-out before the MPU start driving	TLPXD	2xTLPXD	ns	Output
DSI-D0+/-	TTA-GETD	Time to drive LP-00 by display module	5xTLPXD		ns	Input
DSI-D0+/-	TTA-GOD	Time to drive LP-00 after turnaround request-MPU	4xTLPXD		ns	Output

Table 8 Mipi Interface Low Power Mode Timing Characteristics

DSI Bursts Mode

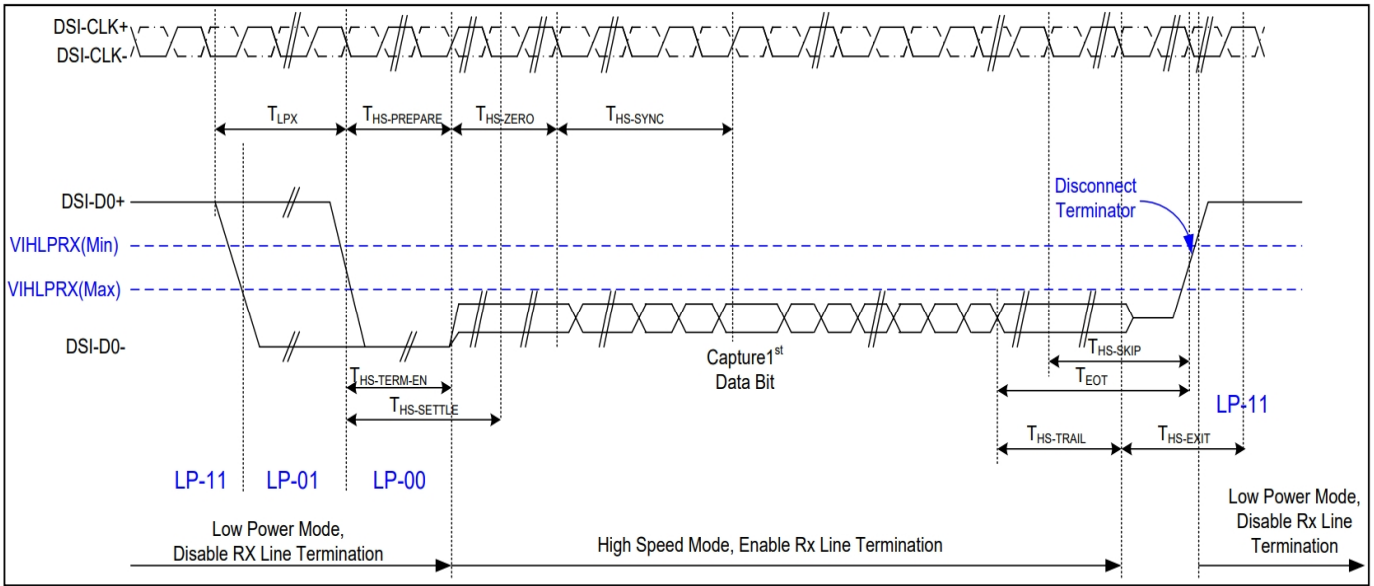

Figure 7 Data lanes-Low Power Mode to/from High Speed Mode Timing

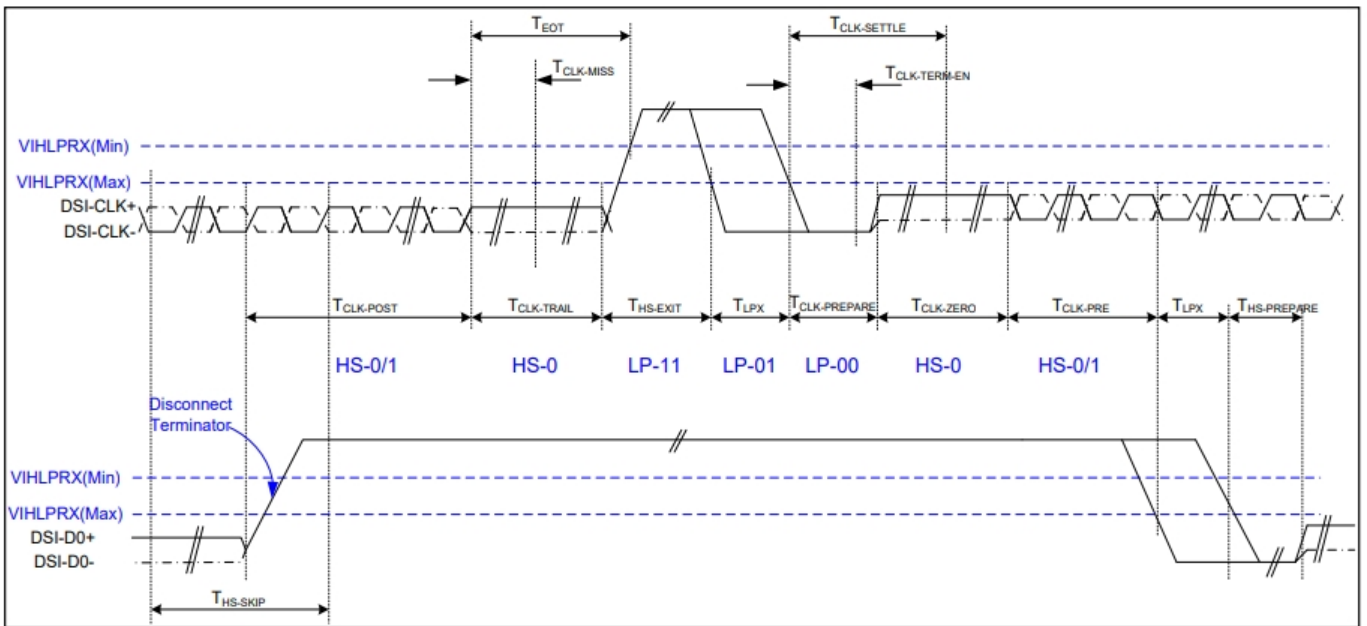

Figure 8 Clock lanes- High Speed Mode to/from Low Power Mode Timing

VDDI=1.8, VDD=2.8, AGND=DGND=0V, Ta=25 °C

Signal	Symbol	Parameter	MIN	MAX	Unit	Description
Low Power Mode to High Speed Mode Timing						
DSI-Dn+/-	TLPX	Length of any low power state period	50	-	ns	Input
DSI-Dn+/-	THS-PREPARE	Time to drive LP-00 to prepare for HS transmission	40+4 UI	85+6 UI	ns	Input
DSI-Dn+/-	THS-TERM-EN	Time to enable data receiver line termination measured from when Dn crosses VILMAX	-	35+4 UI	ns	Input
DSI-Dn+/-	THS-PREPARE + THS-ZERO	THS-PREPARE + time to drive HS-0 before the sync sequence	140+ 10UI	-	ns	Input
High Speed Mode to Low Power Mode Timing						
DSI-Dn+/-	THS-SKIP	Time-out at display module to ignore transition period of EoT	40	55+4 UI	ns	Input
DSI-Dn+/-	THS-EXIT	Time to drive LP-11 after HS burst	100	-	ns	Input
DSI-Dn+/-	THS-TRAIL	Time to drive flipped differential state after last payload data bit of a HS transmission burst	60+4 UI	-	ns	Input
High Speed Mode to/from Low Power Mode Timing						
DSI-CLK+/-	TCLK-POS	Time that the MPU shall continue sending HS clock after the last associated data lane has transition to LP mode	60+5 2UI	-	ns	Input
DSI-CLK+/-	TCLK-TRAIL	Time to drive HS differential state after last payload clock bit of a HS transmission burst	60	-	ns	Input
DSI-CLK+/-	THS-EXIT	Time to drive LP-11 after HS burst	100	-	ns	Input
DSI-CLK+/-	TCLK-PREPARE	Time to drive LP-00 to prepare for HS transmission	38	95	ns	Input
DSI-CLK+/-	TCLK-TERM-EN	Time-out at clock lan display module to enable HS transmission	--	38	ns	Input
DSI-CLK+/-	TCLK-PREPARE + TCLK-ZERO	Minimum lead HS-0 drive period before starting clock	300	-	ns	Input
DSI-CLK+/-	TCLK-PRE	Time that the HS clock shall be driven prior to any associated data lane beginning the transition from LP to HS mode	8UI	-	ns	Input
DSI-CLK+/-	TEOT	Time form start of TCLK-TRAIL period to start of LP-11 state	-	105n s+12 UI	ns	Input

7.5.5 Reset Timing:

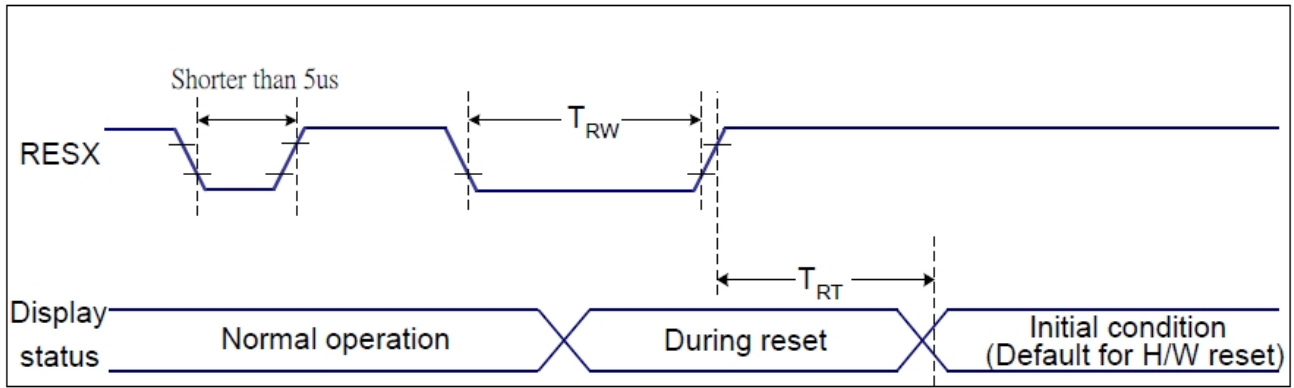

Figure 9 Reset Timing

VDDI=1.8, VDD=2.8, AGND=DGND=0V, Ta=25 °C

Related Pins	Symbol	Parameter	MIN	MAX	Unit
RESX	TRW	Reset pulse duration	10	-	us
	TRT	Reset cancel	-	5 (Note 1, 5)	ms
			120 (Note 1, 6, 7)	ms	

Table 9 Reset Timing

Notes:

1. The reset cancel includes also required time for loading ID bytes, VCOM setting and other settings from NVM (or similar device) to registers. This loading is done every time when there is HW reset cancel time (tRT) within 5 ms after a rising edge of RESX.

2. Spike due to an electrostatic discharge on RESX line does not cause irregular system reset according to the table below:

RESX Pulse	Action
Shorter than 5us	Reset Rejected
Longer than 9us	Reset
Between 5us and 9us	Reset starts

3. During the Resetting period, the display will be blanked (The display is entering blanking sequence, which maximum time is 120 ms, when Reset Starts in Sleep Out –mode. The display remains the blank state in Sleep In –mode.) and then return to Default condition for Hardware Reset.

4. Spike Rejection also applies during a valid reset pulse as shown below:

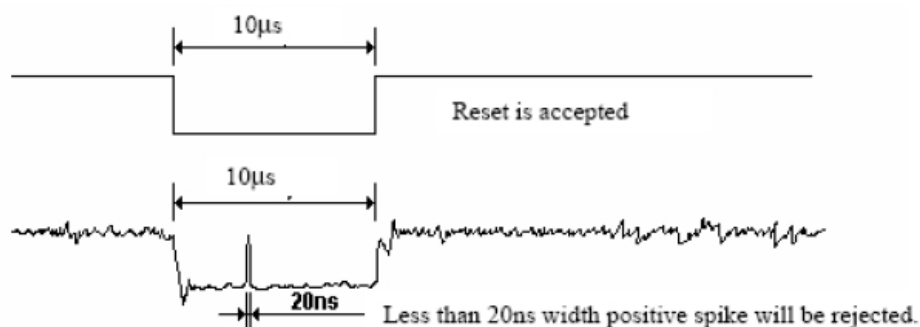

5. When Reset applied during Sleep In Mode.

6. When Reset applied during Sleep Out Mode.

7. It is necessary to wait 5msec after releasing RESX before sending commands. Also Sleep Out command cannot be sent for 120msec.

6.0 ABSOLUTE MAXIMUM RATINGS (Ta = 25°C, Vss = 0 V, Vcc=VDD, IOVCC=VDDI)

Parameter	Symbol	Min	Typ.	Max	Unit
Supply Voltage for Logic	V _{DD}	-0.3	-	4.6	V
Interface Operation Voltage	V _{DDI}	-0.3	-	4.6	V
Driver Supply Voltage	V _{GH-VGL}	-0.3	-	30	V
Input Voltage	V _{IN}	-0.3	-	V _{DDI} +0.3	V
Output Voltage	V _O	-0.3	-	V _{DDI} +0.3	V
Operating Temperature	Top	-20	-	+70	°C
Storage Temperature	Tst	-30	-	+80	°C

7.0 ELECTRICAL CHARACTERISTICS (Ta = 25°C, Vss = 0 V)

Parameter	Symbol	Condition	Min	Typ.	Max	Unit
System Voltage	V _{DD}	-	2.5	3.3	3.6	V
Interface Operation Voltage	IOVCC	-	1.65	1.8	3.3	V
Gate On Power	V _{GH}	-	-	15	-	V
Gate Off Power	V _G L	-	-	-9	-	V
Vcom	V _{com}	-	1.6	-	1.83	V
Logic High Input Voltage	V _{IH}	-	0.7V _{DDI}	-	V _{DDI}	V
Logic Low Input Voltage	V _{IL}	-	V _{ss}	-	0.3V _{DDI}	V
Logic High Output Voltage	V _{OH}	IOH=-1.0mA	0.8V _{DDI}	-	V _{DDI}	V
Logic Low Output Voltage	V _{OL}	IOL= +1.0mA	V _{ss}	-	0.2V _{DDI}	V
LCM Supply Current	I _{LCM}	-	-	TBD	TBD	mA

8.0 ELECTRO-OPTICAL CHARACTERISTICS

No	Item	Symbol	Condition	Min.	Typ.	Max.	Unit	Note	
1	Response Time	$T_{on}+T_{off}$	$\theta = \phi = 0^\circ$	-	30	40	ms	(a)	
2	Contrast Ratio	CR	$\theta = \phi = 0^\circ$	900	1000	-	-	(c)	
3	Viewing Angle (CR ≥ 10)	3:00	$\phi = 0^\circ$	60	80	-	Deg	(b)	
		9:00	$\phi = 180^\circ$	60	80	-	Deg		
		12:00	$\phi = 90^\circ$	60	80	-	Deg		
		6:00	$\phi = 270^\circ$	60	80	-	Deg		
4	Brightness on LCM	L_{LCM}	$\theta = 0^\circ$ $\phi = 0^\circ$ 25°C	400	500	--	cd/m^2	(d)	
5	Color Chromaticity (Center point of LCM) (CIE1931)	White	W_x	$\theta=0^\circ, \phi=0^\circ$ $T_a=25^\circ\text{C}$	0.243	0.293	0.343	-	-
			W_y		0.274	0.324	0.374	-	-
		Red	R_x		0.572	0.622	0.672	-	-
			R_y		0.3	0.350	0.4	-	-
		Green	G_x		0.285	0.335	0.385	-	-
			G_y		0.554	0.604	0.654	-	-
		Blue	B_x		0.1	0.150	0.2	-	-
			B_y		0.055	0.105	0.155	-	-
6	NTSC	60.1%							

Remarks:

- 1) EOC data above is measured using DMS-501 display measurement system.
- 2) Brightness data is measured using photometer Topcon BM-7.

Note(a): Definition of Response Time

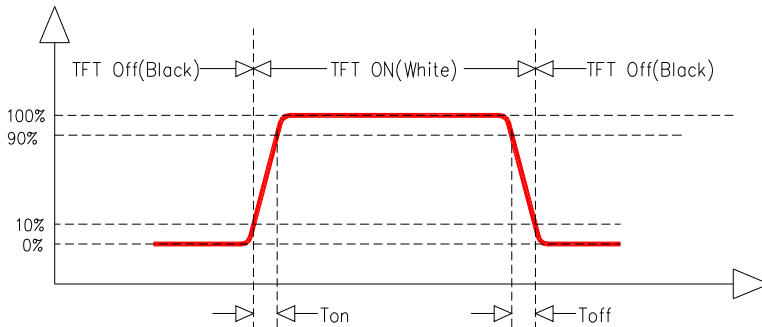

Note (b): Definition of Viewing Angle

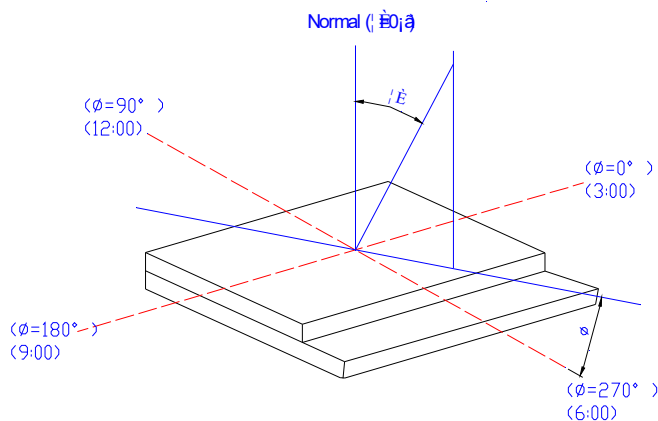

Note (c): Definition of Contrast Ratio

$$CR = \text{Brightness at all pixels "White"} / \text{Brightness at all pixels "Black"}$$

Note (d): backlight driving condition: $I_f = 20\text{mA}$

Luminance measuring point: Center of the dot matrix under white pattern

measuring setup as below figure:

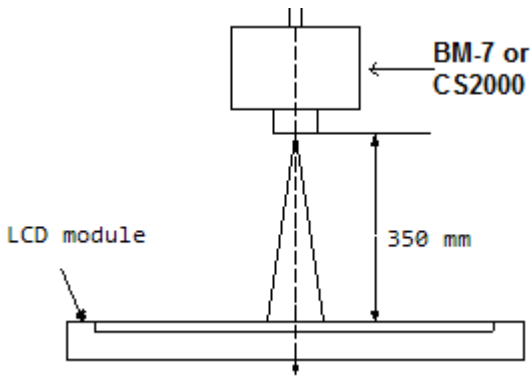

9.0 BACKLIGHT SPECIFICATION

9.1 LED Backlight Electrical-optical characteristics

Item of backlight characteristics	Symbol	Min	Typ	Max	Unit	Condition
Forward Voltage	V_f	16.2	18.0	19.8	V	1. $I_f=20\text{mA}$, $T=25^\circ\text{C}$ 2. Aperture: 1°, 5 Points 3. Average = $\text{min}/\text{max} * 100\%$
Number of LED	-	6			Piece	-
Connection Mode	S/P/M	6 Series			-	-
Life time	30000Hrs (When the LED luminous intensity attenuation to 50% at the beginning of the luminous intensity of time)					$T_a=25^\circ\text{C} \pm 5^\circ\text{C}$, $RH=60\% \pm 10\%$ $I_f=20\text{mA}$ No other interference, such as Current, Voltage suddenly rise, Electrostatic shock, etc.

Remarks: chromaticity and luminance data are measured using photometer Topcon BM-7.

10.0 RELIABILITY SPECIFICATION

10.1 Reliability Test Conditions

No	Test Item	Test Conditions
1	High Temperature Storage	+80°C, 240hrs
2	High Temperature Operation	+70°C, 240hrs
3	Low Temperature Storage	-30°C, 240hrs
4	Low Temperature Operation	-20°C, 240hrs
5	High Temperature Humidity Operation	+60°C, 90%RH, 240hrs
6	Temperature Cycling Storage	-30°C±2°C(30min) ~ 25°C(5min) ~ 80°C±2°C(30min), 10Cycle
7	Vibration Test (on packaging)	Frequency:10-55Hz , Amplitude:0.75mm x,y,z every direction for 0.5 hour
8	Drop Test (on packaging)	Drop to the Ground from 80cm Height, 6 side of carton, each once

Remarks:

- 1) For operation test, above specification is applicable when test pattern is changing during entire operation test.
- 2) Inspections after reliability tests are performed when the display temperature resumes back to room temperature.
- 3) It is a normal characteristic that some display abnormality can be seen during reliability test. If the display abnormality can recover as normal condition within 24 hours at room temperature, there is no permanent destruction over the display. The display still possesses its functionality and considered as acceptable after reliability tests.

10.2 Failure Judgment Criteria

After the reliability tests above, test sample shall be let return to room temperature and humidity for at least 4 hours before final tests are carried out.

Item	Acceptance Criteria
Electrical Characteristic	No electrical short and open. Increase in current consumption is less than 2 times of initial value.
Mechanical Characteristic	Within mechanical and drawing specification
Optical Characteristic	Within appearance standard as specified in this specification. Contrast ratio change & ON-transmission value shall not less than 50% of initial value.

11.0 QUALITY SPECIFICATION

11.1 Acceptable Quality Level (AQL)

Each lot should satisfy the quality level defined as follows:

- a) Inspection method: MIL-STD-105E Level II normal once sampling
- b) AQL level

Category	AQL	Definition
Major	0.25%	Functional defective as product
Minor	0.25%	Satisfy all functions as product but not satisfy cosmetic standard

11.2 Conditions of Inspection

- a) Inspection illumination: Function illumination<150Lux; Appearance illumination is 2500 ± 500Lux.
- b) Inspection distance: About 30cm between the observer's eyes and the LCD.
- c) Inspection angle: Normal inspection angle is +/-10° form LCD.
(Ghost shadow inspection angle is +/-45° ; Light leakage inspection angle is +/-30°)
- d) Inspection environment: normal temperature (18°C~27°C) and normal humidity (50%~85%RH)

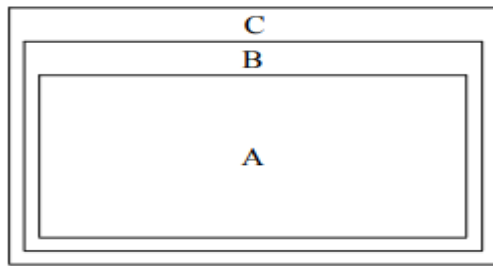
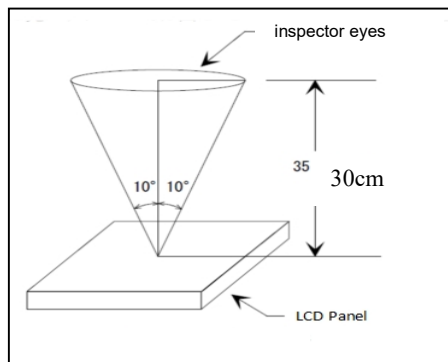



A: viewing area
 B: viewing area except A
 C: Outside viewing area

Note: As a general rule, visual defects in C is permissible, when it is no trouble for quality and assembly of customer's product.

11.3 Acceptance Criteria (Display Elektronik GmbH internal standard: IS-QC- 089(E)TFT-1)

a) Function Inspection

Item	Acceptance/Rejection Criteria		Classification	Method	Method																														
Functional	1. No-display /abnormal display/line defect etc.are not acceptable. 2.Obvious color deviation in dark/red/green/blue screen is not acceptable. (refer limit sample if application) 3.0 Obvious color deviation in the same screen is not acceptable. (spot、mura which cannot be seen by ND6 % is acceptable; Judgement Methods: The distance from the panel to ND filter paper: 350-400 - mm , put the ND filter paper in 1-2 cm distance away from the eye position, using monocular observation) 3.1The standard of eye Sight for Spot,Mura bad:put the filter paper in the the positon in accordance with 3.0,move the eye sight away from the filter paper and turn the sight back to the filter paper.The standard of inspection time for spot,Mura:5 seconds. 4.Current consumption (Idd MAX) shall not exceed the limit specified on the Test Instruction. 5.Display character/ pattern shall be referred to the Test Instruction. 6.Obvious light leakage is not acceptable.		Major	Visual	A																														
Spot Foreign Particle, Dirt under POL or TP	$D=(Length+Width)/2$	<table border="1"> <tr> <th>Zone</th> <th>Acc No</th> </tr> <tr> <td>Size(mm)</td> <td></td> </tr> <tr> <td>D≤0.15</td> <td>Unlimited</td> </tr> <tr> <td>0.15<D≤0.2</td> <td>3</td> </tr> <tr> <td>D>0.2</td> <td>0</td> </tr> </table>	Zone	Acc No	Size(mm)		D≤0.15	Unlimited	0.15<D≤0.2	3	D>0.2	0	Major	Visual (Scale magnifying glass)	A、B、C																				
Zone	Acc No																																		
Size(mm)																																			
D≤0.15	Unlimited																																		
0.15<D≤0.2	3																																		
D>0.2	0																																		
Line defect: foreign or Scratch		<table border="1"> <tr> <th rowspan="2">Defect</th> <th rowspan="2">Size(mm)</th> <th colspan="2">Acc No</th> </tr> <tr> <th>A、B</th> <th>C</th> </tr> <tr> <td rowspan="3">Foreign body、Pit</td> <td>W≤0.02</td> <td>Unlimited</td> <td rowspan="2">Unlimited</td> </tr> <tr> <td>0.02<W≤0.05 and L≤4.0</td> <td>2 (distance ≥ 5mm)</td> </tr> <tr> <td>W≥0.05</td> <td>Define as spot defect</td> </tr> <tr> <td rowspan="3">Polarizer fibrous foreign body</td> <td>W≤0.02</td> <td>Unlimited</td> <td rowspan="2">Unlimited</td> </tr> <tr> <td>0.02<W≤0.05 and L≤4.0</td> <td>2 (distance ≥ 5mm)</td> </tr> <tr> <td>W≥0.05</td> <td>Define as spot defect</td> </tr> <tr> <td rowspan="3">BL fibrous foreign body</td> <td>W≤0.02</td> <td>Unlimited</td> <td rowspan="2">Unlimited</td> </tr> <tr> <td>0.02<W≤0.05 and L≤4.0</td> <td>2 (distance ≥ 5mm)</td> </tr> <tr> <td>W≥0.05</td> <td>Define as spot defect</td> </tr> </table>	Defect	Size(mm)	Acc No		A、B	C	Foreign body、Pit	W≤0.02	Unlimited	Unlimited	0.02<W≤0.05 and L≤4.0	2 (distance ≥ 5mm)	W≥0.05	Define as spot defect	Polarizer fibrous foreign body	W≤0.02	Unlimited	Unlimited	0.02<W≤0.05 and L≤4.0	2 (distance ≥ 5mm)	W≥0.05	Define as spot defect	BL fibrous foreign body	W≤0.02	Unlimited	Unlimited	0.02<W≤0.05 and L≤4.0	2 (distance ≥ 5mm)	W≥0.05	Define as spot defect	Minor	Visual (Scale magnifying glass)	A、B、C
Defect	Size(mm)	Acc No																																	
		A、B	C																																
Foreign body、Pit	W≤0.02	Unlimited	Unlimited																																
	0.02<W≤0.05 and L≤4.0	2 (distance ≥ 5mm)																																	
	W≥0.05	Define as spot defect																																	
Polarizer fibrous foreign body	W≤0.02	Unlimited	Unlimited																																
	0.02<W≤0.05 and L≤4.0	2 (distance ≥ 5mm)																																	
	W≥0.05	Define as spot defect																																	
BL fibrous foreign body	W≤0.02	Unlimited	Unlimited																																
	0.02<W≤0.05 and L≤4.0	2 (distance ≥ 5mm)																																	
	W≥0.05	Define as spot defect																																	
Polarizer Air or TP film bubble	N/A	<table border="1"> <tr> <th rowspan="3">Size(mm)</th> <th colspan="2">Acc No</th> </tr> <tr> <th>A、B</th> <th>C</th> </tr> <tr> <td>D≤0.15</td> <td>Unlimited</td> </tr> <tr> <td>0.15<D≤0.2</td> <td>3</td> <td>Unlimited</td> </tr> </table>	Size(mm)	Acc No		A、B	C	D≤0.15	Unlimited	0.15<D≤0.2	3	Unlimited	Minor	Visual (Scale magnifying glass)	A、B、C																				
Size(mm)	Acc No																																		
	A、B	C																																	
	D≤0.15	Unlimited																																	
0.15<D≤0.2	3	Unlimited																																	

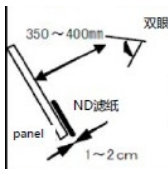
Item	Acceptance/Rejection Criteria			Classification	Method	Method
		0.2 < D ≤ 0.25	1			
		D > 0.25	0			
Light dot Dark dot Definition	<p>1). Pixel definition: Pixel is made of three sub-pixels (Red + Green +Blue)</p>  <p>2). Dot definition: Dot is a sub-pixel (Red or Green or Blue)</p>  <p>3). Light / Dark dot definition: A sub-pixel is on or off when the function testing. Light dot appears in dark picture usually. Dark dot appears in R\G\B color picture or the white picture usually.</p> <p>4). Adjacent dot definition: Adjacent dot is made of two or three sub-pixels(R+G or G+B or B+R or R+G+B);</p>			Minor	Visual (Scale magnifying glass)	A
Bright dot/dark dot	<p>1. If the bright/dark dot size is less than 1/2 size of sub-pixel, ignore the dot.</p> <p>2. If the bright/dark dot size is equal or more than 1/2 size of sub-pixel, follow the acceptable number of dot defect specified in the table on the right.</p> <p>3. Bright dot can not be seen by ND 5% shall follow the tiny bright dot inspection standard.</p> <p>4. Bright dot/dark dot can be seen by ND5% press Acc Qty standard judgement.</p>	Defect	Acc No.	Remark	<p>Visual (Scale magnifying glass)</p> <p>See the judgement method as below</p>  <p>1.0 ND filter paper judgement method for bright dot and tiny bright dot: Distance from the ND filter paper to panel: 1-2 cm position, binocular observation</p> <p>2.0 The standard of eye-sight inspection for Bright dot and tiny Bright dot :put the filter paper in the position in accordance with 1.0, move the eye-sight away from the filter paper and then turn the sight back to the filter paper. The standard of inspection time for Light spot, Light spot 5 seconds.</p>	A
		light dot	3	0		
		light dot two-connection	1	vertical and diagonal connction are not allowed		
		dark dot	3	1		
		dark dot two-connection	1	vertical and diagonal connction are not allowed		
		dark dot three-connection	3	1		
Total	≤3	a two-connection dot count as 2 dots.				
Tiny Bright dot	5. Tiny Bright dot definition, The bright dot can not be seen by ND 6%.			Minor	Visual (Scale magnifying glass)	A
	<p>Tiny bright dot judgement, If the bright dot can not be seen with ND6%, the acceptable Number is unlimited. If the bright dot can be seen with ND6%, the acceptable Number shall ≤10.</p>					
Distance \ Defect number	* 1 Distance between two detects must be more than 5 mm. *2. Total number of defects ≤3.			Minor	Visual (Scale magnifying glass)	A

b) Appearance Inspection

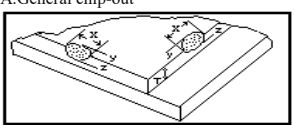
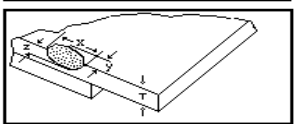
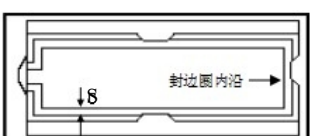
Item	Acceptance/Rejection Criteria			Classification	Method	Method	
Chip-out	<p>A. General chip-out</p>   	x (mm)	y (mm)	z (mm)	Minor	Visual (Scale magnifying glass)	Out of A
		≤4.0	Outside 1/3 S	Ignore			
		S: Innerborder line of the seal					

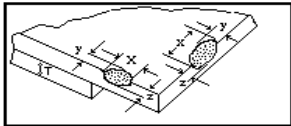
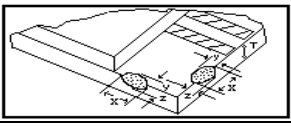
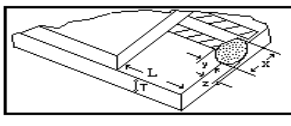
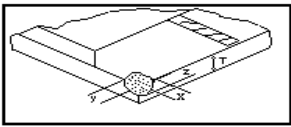
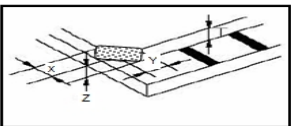
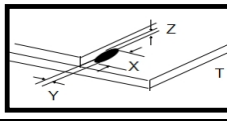
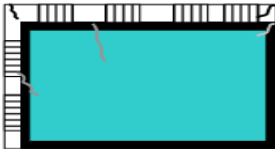
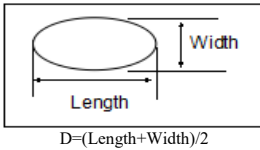
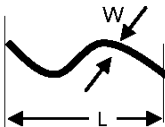
Item	Acceptance/Rejection Criteria	Classification	Method	Method																
B. Chip-out on the back of terminal ledge	 <table border="1"> <thead> <tr> <th>x (mm)</th> <th>y (mm)</th> <th>z (mm)</th> </tr> </thead> <tbody> <tr> <td>Ignore</td> <td>≤ 0.3</td> <td>$\leq 1/2t$</td> </tr> <tr> <td>≤ 4.0</td> <td>$\leq 1/4L$</td> <td>$\leq t$</td> </tr> </tbody> </table>	x (mm)	y (mm)	z (mm)	Ignore	≤ 0.3	$\leq 1/2t$	≤ 4.0	$\leq 1/4L$	$\leq t$										
x (mm)	y (mm)	z (mm)																		
Ignore	≤ 0.3	$\leq 1/2t$																		
≤ 4.0	$\leq 1/4L$	$\leq t$																		
C. Chip-out on the terminal ledge but not exactly on the ITO electrode.	 <table border="1"> <thead> <tr> <th>x (mm)</th> <th>y (mm)</th> <th>z (mm)</th> </tr> </thead> <tbody> <tr> <td>Ignore</td> <td>≤ 0.3</td> <td>$\leq 1/2t$</td> </tr> <tr> <td>≤ 4.0</td> <td>$\leq 1/4L$</td> <td>$\leq t$</td> </tr> </tbody> </table>	x (mm)	y (mm)	z (mm)	Ignore	≤ 0.3	$\leq 1/2t$	≤ 4.0	$\leq 1/4L$	$\leq t$										
x (mm)	y (mm)	z (mm)																		
Ignore	≤ 0.3	$\leq 1/2t$																		
≤ 4.0	$\leq 1/4L$	$\leq t$																		
D. Chip-out on ITO electrode	 <table border="1"> <thead> <tr> <th>x (mm)</th> <th>y (mm)</th> <th>z (mm)</th> </tr> </thead> <tbody> <tr> <td>Ignore</td> <td>≤ 0.3</td> <td>$\leq 1/2t$</td> </tr> <tr> <td>≤ 2.0</td> <td>≤ 0.8</td> <td>$\leq 1/2t$</td> </tr> <tr> <td>≤ 3.0</td> <td>≤ 0.5</td> <td>$\leq t$</td> </tr> </tbody> </table>	x (mm)	y (mm)	z (mm)	Ignore	≤ 0.3	$\leq 1/2t$	≤ 2.0	≤ 0.8	$\leq 1/2t$	≤ 3.0	≤ 0.5	$\leq t$							
x (mm)	y (mm)	z (mm)																		
Ignore	≤ 0.3	$\leq 1/2t$																		
≤ 2.0	≤ 0.8	$\leq 1/2t$																		
≤ 3.0	≤ 0.5	$\leq t$																		
E. Chip-out at corner	 <table border="1"> <thead> <tr> <th>x (mm)</th> <th>y (mm)</th> <th>z (mm)</th> </tr> </thead> <tbody> <tr> <td>≤ 3.0</td> <td>≤ 3.0 or $\leq 1/4L$ (whichever is less)</td> <td>$\leq T$</td> </tr> </tbody> </table>	x (mm)	y (mm)	z (mm)	≤ 3.0	≤ 3.0 or $\leq 1/4L$ (whichever is less)	$\leq T$	Minor	Visual (Scale magnifying glass)	Out of A										
x (mm)	y (mm)	z (mm)																		
≤ 3.0	≤ 3.0 or $\leq 1/4L$ (whichever is less)	$\leq T$																		
F. Chip-out at corner	 <table border="1"> <thead> <tr> <th>x (mm)</th> <th>y (mm)</th> <th>z (mm)</th> </tr> </thead> <tbody> <tr> <td>≤ 3.0</td> <td>≤ 3.0</td> <td>$\leq T$</td> </tr> </tbody> </table> <p>Remark: L= contact pad length, T=Single thickness galss</p>	x (mm)	y (mm)	z (mm)	≤ 3.0	≤ 3.0	$\leq T$													
x (mm)	y (mm)	z (mm)																		
≤ 3.0	≤ 3.0	$\leq T$																		
G. Bur	 <table border="1"> <thead> <tr> <th>x (mm)</th> <th>y (mm)</th> <th>z (mm)</th> </tr> </thead> <tbody> <tr> <td>unlimited</td> <td>≤ 0.2</td> <td>$\leq t$</td> </tr> </tbody> </table>	x (mm)	y (mm)	z (mm)	unlimited	≤ 0.2	$\leq t$													
x (mm)	y (mm)	z (mm)																		
unlimited	≤ 0.2	$\leq t$																		
H. Crack line	 <p>Extended crack is not allowed</p>	Majoy	Visual	Out of A																
Foreign material, Black dot, White dot, Pit, Dent Bubble etc.	 <p>$D=(Length+Width)/2$</p>	<table border="1"> <thead> <tr> <th rowspan="2">Zone</th> <th colspan="2">Acc No.</th> </tr> <tr> <th>A, B</th> <th>C</th> </tr> </thead> <tbody> <tr> <td>Size $D \leq 0.15$</td> <td>Unlimited</td> <td rowspan="3">Unlimited</td> </tr> <tr> <td>$0.15 < D \leq 0.2$</td> <td>3</td> </tr> <tr> <td>$D > 0.2$</td> <td>0</td> </tr> </tbody> </table>	Zone	Acc No.		A, B	C	Size $D \leq 0.15$	Unlimited	Unlimited	$0.15 < D \leq 0.2$	3	$D > 0.2$	0	Minor	Visual (Scale magnifying glass)	A			
Zone	Acc No.																			
	A, B	C																		
Size $D \leq 0.15$	Unlimited	Unlimited																		
$0.15 < D \leq 0.2$	3																			
$D > 0.2$	0																			
Foreign material, Bubble etc.		<table border="1"> <thead> <tr> <th rowspan="2">Defect</th> <th rowspan="2">Size (mm)</th> <th colspan="2">Acc No.</th> </tr> <tr> <th>A, B</th> <th>C</th> </tr> </thead> <tbody> <tr> <td rowspan="3">Foreign body, Pit, Polarizer fibrous foreign body</td> <td>$W \leq 0.02$</td> <td>Unlimited</td> <td rowspan="2">Unlimited</td> </tr> <tr> <td>$0.02 < W \leq 0.05$ and $L \leq 4.0$</td> <td>2 (distance $\geq 5mm$)</td> </tr> <tr> <td>$W \geq 0.05$</td> <td colspan="2">Define as spot defect</td> </tr> </tbody> </table>	Defect	Size (mm)	Acc No.		A, B	C	Foreign body, Pit, Polarizer fibrous foreign body	$W \leq 0.02$	Unlimited	Unlimited	$0.02 < W \leq 0.05$ and $L \leq 4.0$	2 (distance $\geq 5mm$)	$W \geq 0.05$	Define as spot defect		Minor	Visual (Scale magnifying glass)	A
Defect	Size (mm)	Acc No.																		
		A, B	C																	
Foreign body, Pit, Polarizer fibrous foreign body	$W \leq 0.02$	Unlimited	Unlimited																	
	$0.02 < W \leq 0.05$ and $L \leq 4.0$	2 (distance $\geq 5mm$)																		
	$W \geq 0.05$	Define as spot defect																		
Polarizer bubble or TP film bubble	N/A	<table border="1"> <thead> <tr> <th rowspan="2">Size(mn)</th> <th colspan="2">Acc No</th> </tr> <tr> <th>A, B</th> <th>C</th> </tr> </thead> <tbody> <tr> <td>$D \leq 0.15$</td> <td>Unlimited</td> <td rowspan="2">Unlimited</td> </tr> <tr> <td>$0.15 < D \leq 0.2$</td> <td>3</td> </tr> </tbody> </table>	Size(mn)	Acc No		A, B	C	$D \leq 0.15$	Unlimited	Unlimited	$0.15 < D \leq 0.2$	3	Minor	Visual (Scale magnifying glass)	A, B, C					
Size(mn)	Acc No																			
	A, B	C																		
$D \leq 0.15$	Unlimited	Unlimited																		
$0.15 < D \leq 0.2$	3																			

Item	Acceptance/Rejection Criteria	Classification	Method	Method				
	<table border="1"> <tr> <td>0.2 < D ≤ 0.25</td> <td>1</td> </tr> <tr> <td>D > 0.25</td> <td>0</td> </tr> </table>	0.2 < D ≤ 0.25	1	D > 0.25	0			
0.2 < D ≤ 0.25	1							
D > 0.25	0							
Distance	Distance between two detects must be more than 5 mm.	Minor	Visual (Scale magnifying glass)	A				
LC bubble	Not acceptable.	Minor	Visual (Scale magnifying glass)	A				
Polarizer	1.Polarizer dimension & position shall meet the requirement indicated on the drawing. 2.Polarizer orientation shall meet the requirement indicated on the drawing. (Background color shall be consistent with the sample).	Minor	Visual (Scale magnifying glass)	Out of A				
Protective film	1.Protective film separating in Active Area is not acceptable. 2.Fingerprint\ Massive dirt in the polarizer by protective film separating is not acceptable. 3.Erasable smudginess must be cleaned, unerasable smudginess is allowed. .	Minor	Visual (Scale magnifying glass)	All				
FPC cosmetic defect	According to IPC-6013A.	-	Visual	-				
RTV (Tuffy)	1.Coating location shall meet the manufacturing instruction or drawing; Coating shall cover all terminal tracks. 2.RTV pin holes and bubble shall not cause ITO tracks exposed. 3.RTV foreign material shall not cause ITO short-circuit. 4.Uncured coating is not acceptable. 5.RTV Coating cannot be damaged.(Include irregular deformation) 6.RTV coating shall not exceed the height of the polarizer. RTV coating shall not spread over to the polarizer or the interface components. 7.Massive dirt on the coating is not acceptable.	Majoy	Visual	Out of A				
BLU	1. Backlight unit dimension and form shall meet the requirement on the drawing.	Majoy	caliper	Out of A				
	2.Backlight not light up, or wrong lighting color is not acceptable. 3. Acceptance criteria for dark spot, bright spot, and scratch mark shall refer to the spot defect and the line defect of the LCD.4. Uneven brightness in the Viewing Area Zone A is not acceptable. (Refer to the limit sample if applicable). 5.Light leak is not acceptable in main viewing direction. (Refer to the limit sample if applicable). 6. LCD shall not be lifted after assembly.	Minor	Visual	Out of A				
	7.Backlight reflecting film can't separate with BL.							
Label Printing	1.Label printing must clearly visible; fuzzy printing missing printing and pin hole are not allowed. 2.Date lable on LCD cannot be more than 1mm over the BC edge and cannot seen after assembly	Minor	Visual	Out of A				
2.The product shall be free of dirt.	1.The outer dimension shall meet the specification the drawing.	Majoy	caliper	Out of A				
	2.The product shall be free of dirt.	Minor	Visual	Out of A				

12.0 ENVIRONMENTAL SPECIFICATION

This product is designed, manufactured and compliant to below RoHS standard:

- | | |
|---|-------------------|
| 1. Cadmium and Cadmium Compounds | Less than 100ppm |
| 2. Hexavalent Chromium Compounds | Less than 1000ppm |
| 3. Lead and Lead Compounds | Less than 1000ppm |
| 4. Mercury and Mercury Compounds | Less than 1000ppm |
| 5. Polybrominated Biphenyls (PBBs) | Less than 1000ppm |
| 6. Polybrominated Diphenyl ethers (PBDEs) | Less than 1000ppm |
| 7. Butyl benzyl phthalate (BBP) | Less than 1000ppm |
| 8. Bis (2-ethylhexyl)phthalate (DEHP) | Less than 1000ppm |
| 9. Dibutyl phthalate (DBP) | Less than 1000ppm |
| 10. Diisobutyl phthalate(DIBP) | Less than 1000ppm |

13.0 GENERAL PRECAUTIONS FOR USING LCD MODULES

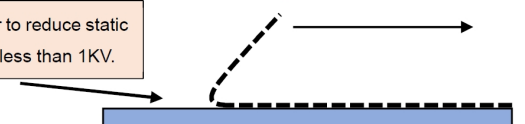
Handling Precaution	Operation Precautions
<ul style="list-style-type: none"> No strong mechanical shock. LCD may be broken because it is made out of glass. Do not work on PCB. PCB may be cracked or damaged. Do not bend or process metal bezel positioning tab. LCD maybe shifted and LCD-PCB interconnection may be damaged, Do not scratch. Polarizer is soft material and can be easily scratched. Liquid crystal may leak when LCD/LCM is broken. Please wash your hands if you touch the liquid crystal. Wear gloves when handling LCD/LCM to avoid damage to LCD/LCM. Please do not touch electrodes with bare hands to avoid any contamination on connection. 	<ul style="list-style-type: none"> Viewing angle can be adjusted by varying driving voltage, V_0 or Vop. Display performance may vary or show abnormal electro-optical performance when viewed at angle beyond the specified viewing angle range. Display color may change under extreme temperature. This is not destructive symptom and display color will resume back to normal when temperature goes back to normal temperature. Driving voltage shall be kept within the specified range as stated in this product specification. Over-voltage may shorten the LCD/LCM lifetime. No DC voltage to LCD/LCM. Electrical characteristics and reliability of LCD/LCM will deteriorate under DC. Please control the DC content in application driving circuit. Avoid using the same display pattern for long time (continuous ON segment). It is a normal phenomena observed for passive driven display where image retention is observed when LCD is displayed with same pattern over 1 hour under temperature $> 55^{\circ}C$. Customer is advised to design application software where display pattern will be changed from time to time, or using the N-line inversion function comes with the display driver IC. If the LCM is using master-slave configuration, customer is strongly recommended to use external V_0. If the LCM comes with MTP/OTP function, customer is recommended to use this MTP/OTP function for the best optical performance.
Soldering Precaution on LCD/LCM	
<ul style="list-style-type: none"> Use soldering iron with proper grounding and no AC leakage. Temperature at tip of soldering iron: $330 \pm 10^{\circ}C$ Type of solder: lead-free solder with resin flux fill. Soldering time: $< 3sec$. Soldering on LCD/LCM I/O terminal only. Do not apply force on the LCD metal pin when soldering. Metal pin connection to LCD terminal will be damaged or loosen by this external force under soldering temperature. Do not solder and de-solder for more than 3 times because metal pin connection or soldering pads will be damaged. 	
Static Electricity	FPC cleanness
<ul style="list-style-type: none"> Avoid static electricity. Please have proper ESD control and ground the human body and any electrical tools when assembling the LCD/LCM. Static electricity will be generated when peeling the protective film. It is a normal behavior that LCD/LCM will response to the static charges generated and will resume back to normal condition slowly. Peeling off the protective film in a correct way is very important to reduce the static electricity and its influence on LCD/LCM. It's recommended that the static electricity is controlled less than 1KV by using ion fan and peeling off protective film slowly and in 45° angle, etc. 	<ul style="list-style-type: none"> If ACF bonding is applied at customer side between FPC and PCB, cleaning on FPC and PCB bonding area (just before bonding) is a must to reduce risk of bonding reliability (eg bonding delamination/spring back phenomenon, low pull strength etc)
<div style="border: 1px solid black; padding: 5px; margin-bottom: 5px;"> <p>Speed: Slowly peeling off the protective film to make sure static electricity less than 1KV.</p> </div> <div style="border: 1px solid black; padding: 5px; margin-bottom: 5px;"> <p>Angle: direction of removing protective film is $45^{\circ} \pm 15^{\circ}$</p> </div> <div style="border: 1px solid black; padding: 5px; margin-bottom: 5px;"> <p>Ionized air to reduce static electricity less than 1KV.</p> </div> 	Long-term Storage Conditions
<ul style="list-style-type: none"> Store LCD/LCM in dark area and keep LCD/LCM away from direct sunlight and fluorescent light. Store LCD/LCM under temperature range of $0 \sim 35^{\circ}C$ and room humidity of $50 \sim 60\%RH$. Possible Vop adjustment might be needed at customer side after prolong storage over 1 year from date of manufacturing. 	

14.0 APPENDIX**14.1 Functional testing pattern**

Below test patterns will be used at all LCM functional tests at mass production stage. Acceptance of a product during inspection will be judged based on these test patterns only. Customer should notify Display Elektronik GmbH if different test patterns being used at customer side to ensure same testing platform between Customer and Display Elektronik GmbH, especially on those defects (flickering, image sticking, cross-talk, black/white line) which are pattern-dependent. These test patterns are by default agreed by both Customer and Display Elektronik GmbH, unless notified by Customer to revise such test patterns. If the defect listed in above description is seen in below pattern, LCD module should be judged as NG and vice versa.

TBD