

REVISION RECORD				
REV	ECN	DESCRIPTION	DRFT	DATE



仅供参考图

签字: *董贵凡*

日期: 2015.11.18.

NOTES1:
 UL Standard
 1. Rated Voltage/Current : 600V / 50A
 2. Withstanding Voltage : AC2200V/1Min.
 3. Torque Value : M4 , 10.53Lb.in
 4. Wire Range : 26~12AWG

IEC Standard

1. Pollution Degree	3
Overvoltage Category	III
Rate Impulse Voltage(KV)	8.0KV
Rate Voltage(V)	1000V
Rate Current(A)	41A

2. Torque Value : M4 , 1.2N.m
 3. Wire Range : 0.5~6mm²

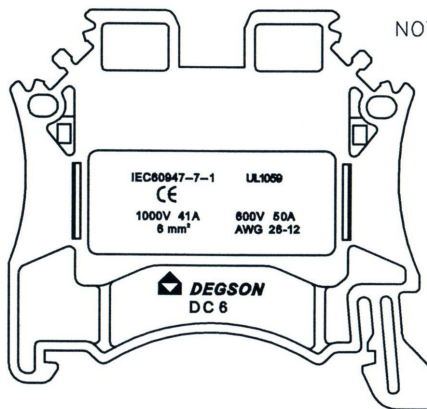
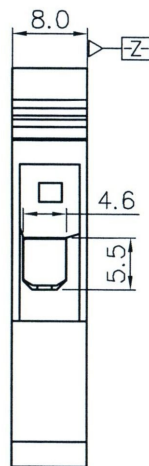
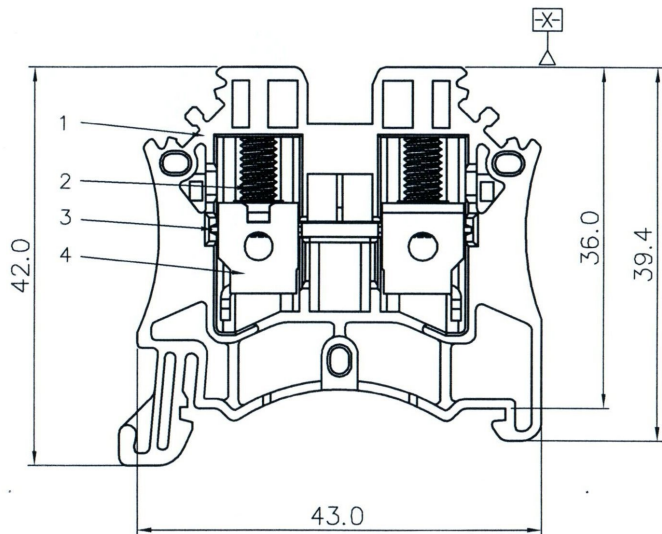

NOTES2:
 1. Dimension shall be interpreted per ASME Y14.5-2009
 2. Pitch : 8.0mm, Poles : 01P
 3. Stripping length : 10-12mm
 4. Operating temperature: -40°C~+105°C
 5. Undimensioned Tolerances:

Pitch Range In mm		Nominal Dimension Range In mm						0.1/10
TO	Over	TO	Over	TO	Over	TO	Over	
6	10	6	10	30	60	100	150	<
±0.15	±0.20	±0.30	±0.30	±0.50	±0.70	±1.00	±1.30	±2*

6. RoHS Compliance

ITEM	NAME OF PART	Q'TY	MATERIAL	NOTES
4	GAGE	2	STEEL	M4/Zn PLATED
3	CURRENT CARRIER	1	COPPER ALLOY	Sn PLATED
2	SCREW	2	STEEL	M4/Zn PLATED
1	HOUSING	1	PA66	UL94V-0

DETACHED LISTS	PART NO.: /	宁波高松电子有限公司 DEGSON ® NINGBO DEGSON ELECTRICAL CO., LTD		
	APPD: <i>Alan 11/18/15</i>	NAME: DC6-01P-1Y-00A(H)		
	CHKD: <i>Dixley 2015-11-19</i>	TITLE: CUSTOMER DRAWING		
	DRFT: ding 2015/10/29	DRAWING NO.: DC6-C01	REV	D0-1
THIRD ANGLE PROJECTION		DRAWING NO.: DC6-C01	SHEET	1/1
← MM (INCH) →		DO NOT SCALE DRAWING	SCALE	1:1