

REVISION RECORD				
REV	ECN	DESCRIPTION	DRFT	DATE
00-2		接地体结构变更	ZYK	2016.08.02
00-3		最小线径变更	ZYK	2016.08.29

NOTES1:

UL Standard

- 1.Torque value : M6 , 31Lb.in
- 2.Wire range : 14~2AWG

IEC Standard

1.

Pollution degree	3
Overvoltage category	III
Rate impulse voltage(KV)	8.0KV
- 2.Torque value : M6 , 3.5N·m
- 3.Wire range : 2.5~35mm²

00-3

NOTES2:

- 1.Dimension shall be interpreted per ASME Y14.5-2009
- 2.Pitch : 16.00mm, Poles : N=01P
- 3.Stripping length : 14~16mm
- 4.Operating temperature: -40°C~+105°C
- 5.Undimensioned tolerances:

Pitch range in mm	Nominal dimension range in mm							- / \square / ∇	
	Over 6 TO 6	Over 10 TO 10	Over 10 TO 24	Over 30 TO 30	Over 30 TO 60	Over 60 TO 100	Over 100 TO 150		Over 150 TO 150
	±0.15	±0.20	±0.30	±0.30	±0.50	±0.70	±1.00	±1.30	±2'

6.RoHS Compliance

ITEM	NAME OF PART	MATERIAL	NOTES
6	SCREW	STEEL	M6\Zn Plated
5	WIRE CAGE	STEEL	M6\Zn Plated
4	CONDUCTOR	COPPER ALLOY	Sn Plated
3	COVER	PA66	UL94V-0
2	GROUND CONTACT	COPPER ALLOY	Sn Plated
1	HOUSING	PA66	UL94V-0

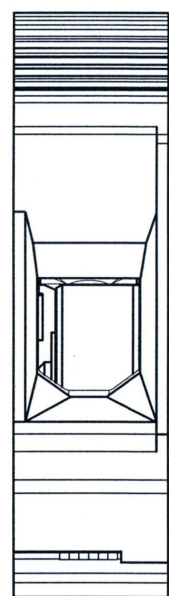
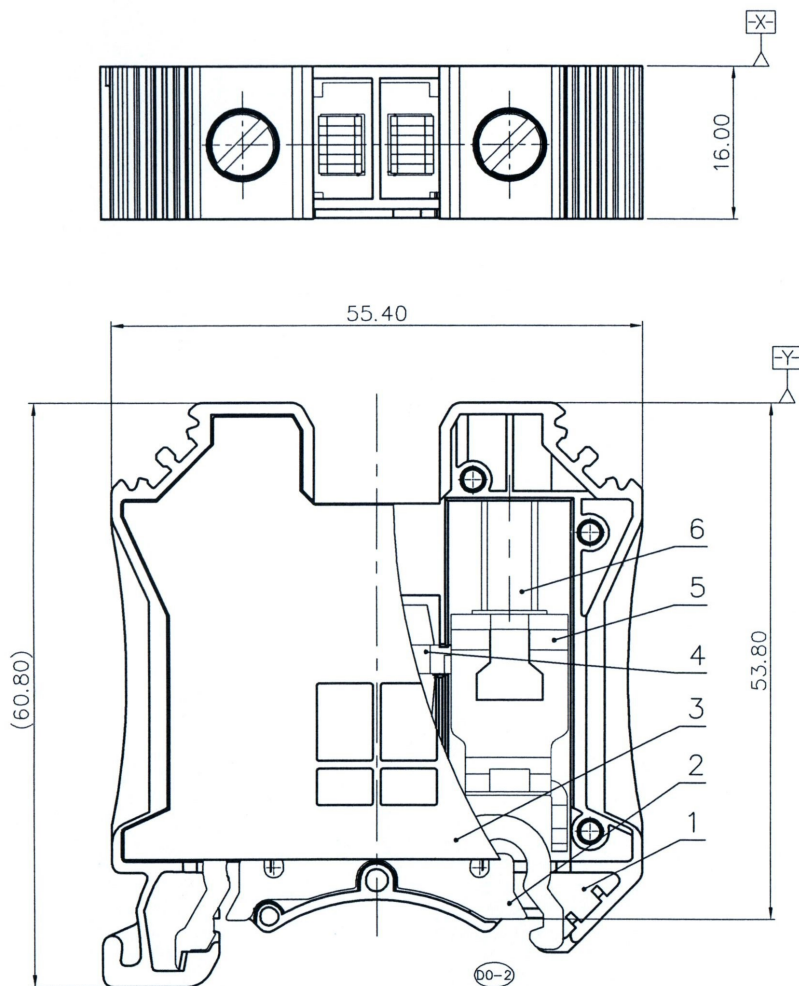

仅供参考图
 签字: 李 磊 保
 日期: 2016.09.09 (首样)
 (仅限内部使用, 对外无效)

DETACHED LISTS	PART NO.:	/		
	APPD:	NAME: DEGSON 宁波高松电子有限公司 NINGBO DEGSON ELECTRICAL CO., LTD		
	CHKD:	DC35-PE-01P-1C-00A(H)		
	DRFT: ZYK 07/07/16"	TITLE: CUSTOMER DRAWING	REV	DO-3
	DRAWING NO.:	DC35-PE-C01	SHEET	1/1
		MM (INCH)	DO NOT SCALE DRAWING	SCALE 1:1

