



The Driving Evolution

- High starting torque in open loop: 200% at 0.3 Hz, Full torque at 0 Hz in closed loop
- Sensor-less and vector closed-loop control
- Triple rating: VLD 110%/1min, LD 120%/1 min and ND 150%/1 min
- Built-in EMC filter, logic programming and application functionality
- Safe Torque Off (STO) according to EN ISO 13849-1:2008 (Safety Category 3/PLd) and IEC 60204-1 Stop Category 0
- IM & PM motor control
- Communication options: EtherCAT, PROFIBUS, PROFINET, Modbus TCP
- Regenerative solutions as option
- CE, CULus, RoHS

Ratings

- 200 V class three-phase: 0.4 kW to 55 kW
- 400 V class three-phase: 0.75 kW to 132 kW

System configuration

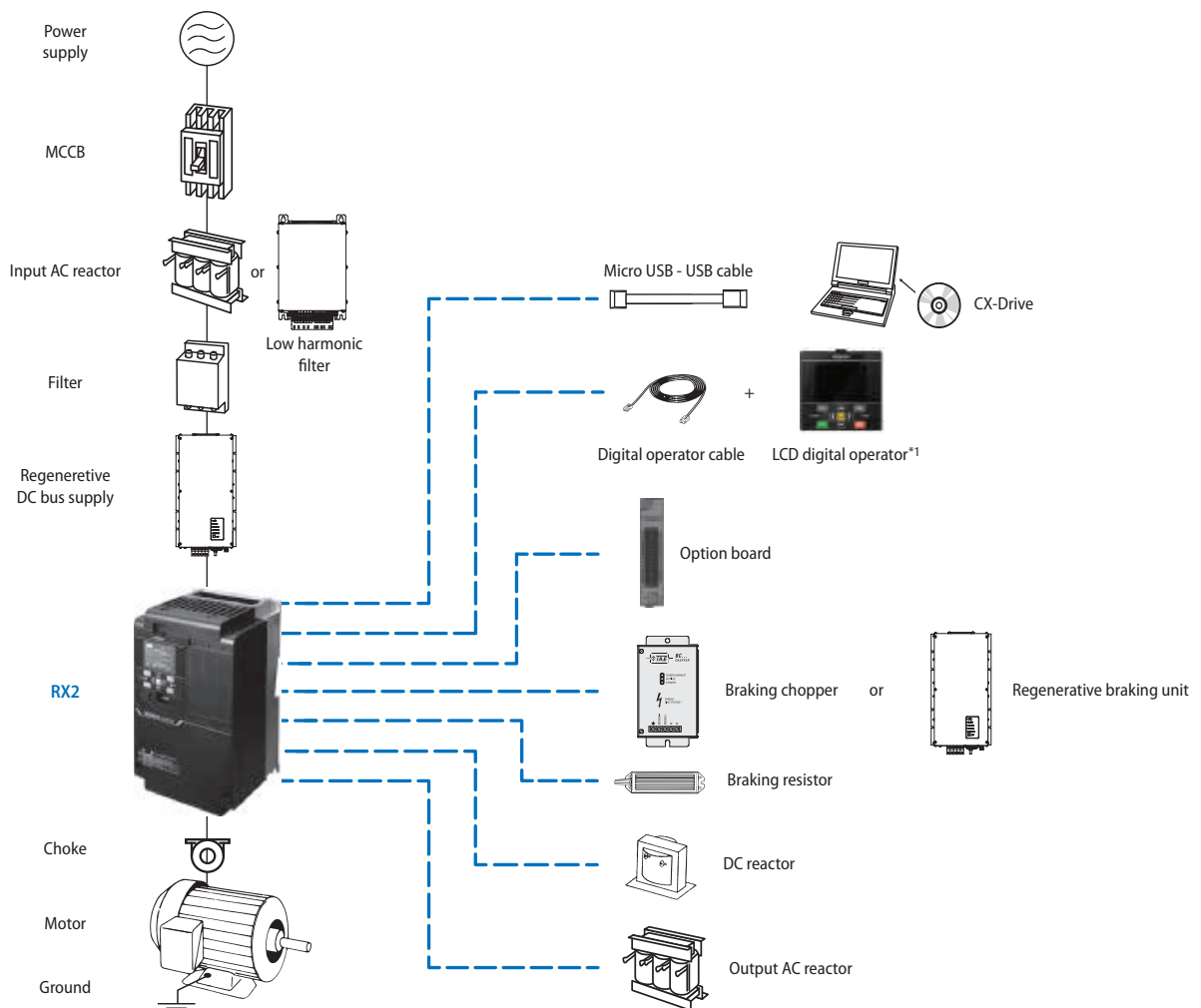

*1 The LCD digital operator is provided with the inverter from factory.

Type designation

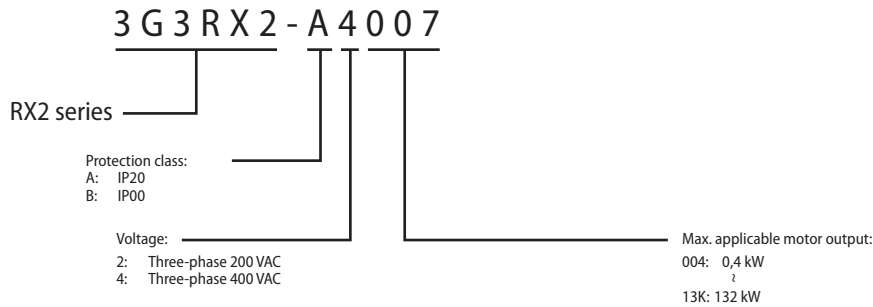

Specifications

Common specifications

Item	Specifications
Control mode (output to the motor)	Sine wave PWM control voltage output (line sine wave modulation)
Output frequency range *1	0.00 to 590.00 Hz
Frequency accuracy	Digital command $\pm 0.01\%$ and analog command $\pm 0.2\%$ (25°C $\pm 10^\circ\text{C}$) against the maximum frequency
Frequency resolution	Digital setting: 0.01 Hz Analog setting: maximum frequency/4000 (Ai1 terminal/Ai2 terminal: 12 bit/0 to +10 V or 0 to +20 mA, Ai3 terminal 12 bit/-10 to +10 V)
Control mode (frequency/voltage calculation) *2	IM V/f control (fixed torque/reduced torque/free), automatic boost control, cascade model sensorless vector control, 0 Hz range sensorless vector control, vector control with sensor. SM/PMM Synchronous starting sensorless vector control, IVMS starting smart sensorless vector control
Speed fluctuation *3	$\pm 0.5\%$ (during sensorless vector control)
Acceleration or deceleration time	0.00 to 3600.00 sec (linear, S-shaped, U-shaped, reverse U-shaped, EL-S shaped)
Display monitor	Output frequency, output current, output torque, trip history, I/O terminal status, I/O power *4, P-N voltage.
Starting functions	Start after DC braking, frequency collection start, frequency entrainment start, reduced voltage start, retry start
Stopping functions	Free-run stop, DC braking after deceleration stop or terminal DC braking (braking power, operating speed adjustment)
Stall prevention function	Overload restraining function, overcurrent suppression function, overvoltage suppression function
Protective function *5	Overcurrent error, Motor overload error, Braking resistor Overload error, Overvoltage error, Memory error, Undervoltage error, Current detector error, CPU error, External trip error, USP error, Ground fault error, Incoming over voltage error, Instantaneous power failure error, Temperature detector error, Cooling fan rotation speed reduction temperature error, Temperature error, Input open-phase error, IGBT error, Output open-phase error, Thermistor error, Brake error, Low-speed range overload error, Controller overload error, RS485 communication error, Operator keypad disconnection error.
Other functions	V/f free settings (7 points), Upper/lower limit frequency limiter, Frequency jump, Curve acceleration/deceleration, Manual torque boost, Energy-saving operation, Analog output adjustment function, Minimum frequency, Carrier frequency adjustment, Motor electronic thermal function (free setting is also possible), Inverter electronic thermal function, External start/end (volume/ratio), Frequency input selection, Trip retry, Restart after instantaneous stop, Output of signals, Initialization settings, PID control, Automatic deceleration at power shut-off, Brake control function, and Auto-tuning for commercial switching function (online/offline).

Input	Frequency setting	Standard operator keypad	External signals *6	External port
Input terminal function	Standard operator keypad	Ai1/Ai2 terminal (when changing voltage)	Setting through input of 0 to 10 VDC voltage (input impedance: 10 k Ω)	Setting via RS485 serial communication (protocol: Modbus-RTU)
		Ai1/Ai2 terminal (when changing current)	Setting through input of 0 to 20 mA current (input impedance: 100 Ω)	
		Ai3 terminal	Setting through input of -10 to +10 V voltage (input impedance: 10 k Ω)	
		Multistage speed terminal (use of input terminal function)	15 speed	
		Pulse string input (A/B terminal, use of input terminal function)	32 kHz \times 2 at maximum	
		External port	Setting via RS485 serial communication (protocol: Modbus-RTU)	
Normal rotation/reverse rotation Run/stop	Standard operator keypad	Execution with the RUN /STOP key (normal rotation/reverse rotation can be switched by setting parameters)	Normal rotation operation (FW)/reverse rotation (RV) (when an input terminal function is assigned) 3-wire input available (when an input terminal function is assigned)	Setting via RS485 serial communication (protocol: Modbus-RTU (maximum: 115.2 kbps)
		External signals		
		External port		
Backup power supply terminal	STO input terminal	11 terminals (input of pulse string is available on terminal A and B)		
		FW (Normal rotation)/RV (Reverse rotation), CF1-4 (Multistage speed 1-4), SF1-7 (Multistage speed bit 1-7), ADD (Addition of frequency), SCHG (Switching of frequency command), STA (3-wire start)/STP (3-wire stop)/F_R (3-wire normal/reverse), AHD (Retention of analog command), FUP (Increase of speed via remote operation/FDN (Deceleration via remote operation), UDC (Deletion of data via remote operation), F-OP (Forced command switching), SET (Second control), RS (Reset), JG (Jogging), DB (External current braking), 2CH (2-stage acceleration/deceleration), FRS (Free-run stop), EXT (External abnormality), USP (Prevention of restart after restoration of power), CS (Commercial switching), SFT (Soft-lock), BOK (Brake check), OLR (Overload restriction switching), KHC (Clearance of integrated input power), OKHC (Clearance of integrated output power), PID (PID1 disabled), PIDC (PID1 integration reset), PID2 (PID2 disabled), PIDC2 (PID2 integration reset), SVC1-4 (PID1 multistage target values 1-4), PRO (PID gain switching), PIO (PID output switching), SLEP (SLEEP condition satisfied)/WAKE (WAKE condition satisfied), TL (Torque restriction enabled), TRQ1, 2 (Switching of torque limit 1, 2), PPI (Switching of P/PI control), CAS (Switching of control gain), FOC (Preparatory excitation), ATR (Torque control enabled), TBS (Torque bias enabled), LAC (Cancellation of acceleration/deceleration), Mi1-11 (General-purpose input 1-11), PCC (Clearance of pulse counter), ECOM (Start of EzCOM), PRG (Program run), HLD (Acceleration/deceleration stop), REN (Operation permission signal), PLA (Pulse string input A), and PLB (Pulse string input B)		
		P+/P-: DC24V input (allowable input voltage: 24 V $\pm 10\%$)		
		2 terminals (simultaneous input)		
		1 terminal (possible to switch between positive temperature coefficient/negative temperature coefficient resistance element)		

Item		Specifications
Output	Output terminal function	Transistor output 5 terminal, 1a contact relay 1 point, 1c contact relay 1 point
	Relay and alarm relay (16, AL)	RUN (During operation), FA1-5 (Reached signal), IRDY (Operation ready completion), FWR (During normal rotation operation), RVR (During reverse rotation operation), FREF (Frequency command operator keypad), REF (Operation command operator keypad), SETM (Second control under selection), AL (Alarm signal), MJA (Severe failure signal), OTQ (Over torque) ^{*7} , IP (During instantaneous power failure), UV (Under insufficient voltage), TRQ (During torque limitation), IPS (During power failure deceleration), RNT (RUN time over), ONT (Power on time over), THM (Electronic thermal warning), THC (Electronic thermal warning), WAC (Capacitor life advance notice), WAF (Fan life advance notice), FR (Operation command signal), OHF (Cooling fin heating advance notice), LOC/LOC2 (Low-current signal), OL/OL2 (Overload advance notice), BRK (Brake release), BER (Brake abnormality), ZS (Zero-speed detection signal), OD/OD2 (PID deviation excessive), FBV/FBV2 (PID feedback comparison), NDc (Communication disconnection), Ai1Dc/Ai2Dc/Ai3Dc (Analog disconnection Ai1/Ai2/Ai3), WCAi1/WCAi2/WCAi3 (Window comparator Ai1/Ai2/Ai3), LOG1-7 (Logical operation result 1-7), MO1-7 (General output 1-7), and OVS (Receiving overvoltage).
	EDM output terminal	Output for STO diagnosis
	Monitor output terminal ^{*8}	Possible to output through selection from monitor data of parameters
EMC filter switching ^{*9}		Possible to enable the EMC noise filter (switching method is different depending on the model)
External access to PC		USB Micro-B
Use environment	Ambient temperature ^{*10}	ND (normal duty) -10 to 50°C
		LD (low duty) -10 to 45°C
		VLD (very low duty) -10 to 40°C
	Storage temperature ^{*11}	-20 to 65°C
	Humidity	20-90%RH (location free of condensation)
Vibration ^{*12}	5.9 m/s ² (0.6 G) 10 to 55 Hz: 3G3RX2-A2004 to A2220 / 3G3RX2-A4007 to A4220 2.94 m/s ² (0.3 G) 10 to 55 Hz: 3G3RX2-A2300 to A2550 / 3G3RX2-A4300 to A413K	
Use location ^{*13}	1000 m altitude or lower (location free from corrosive gas, oil mist, and dust)	
Expected Life time	Smoothing capacitor 10 years	
	Designed life of cooling fan 10 years (models equipped with a cooling fan) free from dust	
	Memory element on the control circuit board	
Applicable standards ^{*14}		Compliance with UL/cUL/CE standards, RCM, Functional Safety SIL3/PLe (to be obtained)
Painting color		Black
Operating, display		LCD Operator ^{*15}
Number of option slots		3 ports
Other options		Braking resistor, AC reactor, DC reactor, noise filter

^{*1} The output frequency range depend on the control and motor used. When running the inverter exceeding 60 Hz, check the maximum allowable frequency with the manufacturer of the motor.

^{*2} When the control mode is changed, unless the motor constant is appropriately configured, you cannot obtain the desired starting torque or the inverter may trip.

^{*3} The variable range of motor speed may vary depending on your system or the environment where the motor is used. Please contact us for details.

^{*4} Both the input power and output power are reference values, which are not appropriate for use in calculation of efficiency values, etc. To obtain an accurate value, use an external device.

^{*5} The IGBT error [E030] is generated by the protective function not only for short circuit protection but also when IGBT is damaged. Depending on the operating conditions of the inverter, the overcurrent error [E001] may occur, instead of the IGBT error.

^{*6} At the factory default setting, when voltage and current on Ai1/Ai2 terminal is changed using a switch, with input of voltage at 9.8 V and current at 19.8 mA, the maximum frequency is commanded. To change characteristics, make adjustments using the analog start/end function.

^{*7} The threshold for signal output varies depending on the motor to be combined with the inverter, parameter adjustment, etc.

^{*8} The output data of analog voltage monitor and analog current monitor are reference values for connecting an analog meter. Due to the meter to be connected and variation in analog output circuit, the maximum output value may slightly vary from 10 V or 20 mA. To change characteristics, make adjustments using the Ao1 adjustment and Ao2 adjustment functions. Some monitor data cannot be output.

^{*9} To enable the EMC filter, connect with a power supply grounded at a neutral point. Otherwise, the leakage current may increase.

^{*10} Use the 400 V class inverter at an input voltage of 500 VAC or below. If input voltage exceeds 500 VAC due to fluctuation of power, use the inverter at 40°C or lower ambient temperature.

^{*11} The storage temperature is the temperature during transport.

^{*12} To be in accordance with the testing method specified in JIS C 60068-2-6: 2010 (IEC 60068-2-6:2007)

^{*13} When the inverter is used in a location at 1000 m or higher altitude, air pressure reduces approximately 1% every 100 m elevation. Perform 1% current derating and conduct evaluation for every 100 m elevation.

^{*14} For insulation distance, comply with UL and CE standards

^{*15} When a clock function is used, the optional battery (CR2032, 3 V) is required. When you purchase, this LCD operator does not come with the battery.

3G3RX2 200 V class

Very Low Duty (VLD)/Low Duty (LD)/Normal Duty (ND)

3G3RX2-□□□□□□		A2004	A2007	A2015	A2022	A2037	A2055	A2075	A2110	A2150	A2185	A2220	A2300	A2370	A2450	A2550	
Applicable motor (4-pole) capacity (kW)	VLD	0.75	1.5	2.2	3.7	5.5	7.5	11	15	18.5	22	30	37	45	55	75	
	LD	0.75	1.5	2.2	3.7	5.5	7.5	11	15	18.5	22	30	37	45	55	75	
	ND	0.4	0.75	1.5	2.2	3.7	5.5	7.5	11	15	18.5	22	30	37	45	55	
Output	Rated output current (A)	VLD	4.4	8.0	10.4	15.6	22.8	33.0	46.0	60.0	80.0	93.0	124	153	185	229	295
		LD	3.7	6.3	9.4	12.0	19.6	30.0	40.0	56.0	73.0	85.0	113	140	169	210	270
		ND	3.2	5.0	8.0	11.0	17.5	25.0	32.0	46.0	64.0	76.0	95.0	122	146	182	220
Output	Overload current rating	VLD	110% 60 sec / 120% 3 sec														
		LD	120% 60 sec / 150% 3 sec														
		ND	150% 60 sec / 200% 3 sec														
Rated output voltage		3-phase (3-wire) 200 to 240 V (depending on receiving voltage)															
Rated capacity (kVA)	200 V	VLD	1.5	2.8	3.6	5.4	7.9	11.4	15.9	20.8	27.7	32.2	43.0	53.0	64.1	79.3	102.2
		LD	1.3	2.2	3.3	4.2	6.8	10.4	13.9	19.4	25.3	29.4	39.1	48.5	58.5	72.7	93.5
		ND	1.1	1.7	2.8	3.8	6.1	8.7	11.1	15.9	22.2	26.3	32.9	42.3	50.6	63.0	76.2
	240 V	VLD	1.8	3.3	4.3	6.5	9.5	13.7	19.1	24.9	33.3	38.7	51.5	63.6	76.9	95.2	122.6
		LD	1.5	2.6	3.9	5.0	8.1	12.5	16.6	23.3	30.3	35.3	47.0	58.2	70.3	87.3	112.2
		ND	1.3	2.1	3.3	4.6	7.3	10.4	13.3	19.1	26.6	31.6	39.5	50.7	60.7	75.7	91.5
Input	Rated input current (A) *1	VLD	5.2	9.5	12.4	18.6	27.1	39.3	54.8	71.4	95.2	110.7	147.6	182.1	220.2	272.6	351.2
		LD	4.4	7.5	11.2	14.3	23.3	35.7	47.6	66.7	86.9	101.2	134.5	166.7	201.2	250.0	321.4
		ND	3.8	6.0	9.5	13.1	20.8	29.8	38.1	54.8	76.2	90.5	113.1	145.2	173.8	216.7	261.9
Rated input AC voltage		Control power supply: Power supply single phase 200 to 240 V/allowable variation range 170 to 264 V, 50 Hz (allowable variation range: 47.5 to 52.5 Hz)/60 Hz (allowable variation range: 57 to 63 Hz) Main circuit power supply: 3-phase (3-wire) 200 to 240 V/allowable variation range 170 to 264 V, 50 Hz (allowable variation range: 47.5 to 52.5 Hz)/60 Hz (allowable variation range: 57 to 63 Hz)															
Power supply equipment capacity (kVA) *2	VLD	2.0	3.6	4.7	7.1	10.3	15.0	20.9	27.2	36.3	42.2	56.3	69.4	83.9	103.9	133.8	
	LD	1.7	2.9	4.3	5.4	8.9	13.6	18.1	25.4	33.1	38.6	51.3	63.5	76.7	95.3	122.5	
	ND	1.5	2.3	3.6	5.0	7.9	11.3	14.5	20.9	29.0	34.5	43.1	55.3	66.2	82.6	99.8	
Carrier frequency operating range *3	VLD	0.5 to 10.0 kHz															
	LD	0.5 to 12.0 kHz															
	ND	0.5 to 16.0 kHz															
Motor start torque *4		200%/0.3 Hz															
Braking	Regenerative braking	Equipped with BRD circuit (with a discharging resistor separately installed)										Regenerative braking unit separately installed					
	Minimum resistance that can be connected (Ω)	50	50	35	35	35	16	10	10	7.5	7.5	5	---	---	---	---	
Dimension	Height (mm)	255	255	255	255	255	260	260	260	390	390	390	540	550	550	700	
	Width (mm)	150	150	150	150	150	210	210	210	245	245	245	300	390	390	480	
	Depth (mm)	140	140	140	140	140	170	170	170	190	190	190	195	250	250	250	
Protection class		IP20 *5 / UL open type															
Approximate mass (kg)		3	3	3	3	3	6	6	6	10	10	10	22	33	33	47	

*1 The rated input currents shown in the table are the values when the rated current is output. The values vary depending on impedance on the power supply (wiring, breaker, input reactor option, etc.)

*2 The power supply equipment capacities shown in the table are the values when 220 V rated current is output. The values vary depending on impedance on the power supply (wiring, breaker, input reactor option, etc.)

*3 The setting of rated values for carrier frequencies [bb101]/[bb201] are internally limited in accordance with the description. Also, it is recommended to set values equivalent to or above (maximum output frequency for driving $\times 10$) Hz for the setting of carrier frequencies [bb101]/[bb201]. Also, in the case of induction motor (IM) control, for items other than those subject to V/f control, it is recommended to set carrier frequency at 2 kHz or more. In the case of synchronous motor (SM)/permanent magnet motor (PMM) control, it is recommended to set carrier frequency at 8 kHz or more.

*4 The value of the sensor-less vector control applied to the ND rating in the Standard motor. Torque characteristics may vary depending on the control method and the motor used.

*5 Based on self declaration.

3G3RX2 400 V class

Very Low Duty (VLD)/Low Duty (LD)/Normal Duty (ND)

3G3RX2-□□□□□□		A4007	A4015	A4022	A4037	A4055	A4075	A4110	A4150	A4185	A4220	A4300	A4370	A4450	A4550	B4750	B4900	B411K	B413K		
Applicable motor (4-pole) capacity (kW)	VLD	1.5	2.2	3.7	5.5	7.5	11	15	18.5	22	30	37	45	55	75	90	110	132	160		
	LD	1.5	2.2	3.7	5.5	7.5	11	15	18.5	22	30	37	45	55	75	90	110	132	160		
	ND	0.75	1.5	2.2	3.7	5.5	7.5	11	15	18.5	22	30	37	45	55	75	90	110	132		
Output	Rated output current (A)	VLD	4.1	5.4	8.3	12.6	17.5	25.0	31.0	40.0	47.0	62.0	77.0	93.0	116	147	176	213	252	316	
		LD	3.1	4.8	6.7	11.1	16.0	22.0	29.0	37.0	43.0	57.0	70.0	85.0	105	135	160	195	230	290	
		ND	2.5	4.0	5.5	9.2	14.8	19.0	25.0	32.0	39.0	48.0	61.0	75.0	91.0	112	150	180	217	260	
Output	Overload current rating	VLD	110% 60 sec / 120% 3 sec																		
		LD	120% 60 sec / 150% 3 sec																		
		ND	150% 60 sec / 200% 3 sec																		
Rated output voltage		3-phase (3-wire) 380 to 500 V (depending on receiving voltage)																			
Output	Rated capacity (kVA)	400 V	VLD	2.8	3.7	5.8	8.7	12.1	17.3	21.5	27.7	32.6	43.0	53.3	64.4	80.4	101.8	121.9	147.6	174.6	218.9
			LD	2.1	3.3	4.6	7.7	11.1	15.2	20.1	25.6	29.8	39.5	48.5	58.9	72.7	93.5	110.9	135.1	159.3	200.9
			ND	1.7	2.8	3.8	6.4	10.3	13.2	17.3	22.2	27.0	33.3	42.3	52.0	63.0	77.6	103.9	124.7	150.3	180.1
		500 V	VLD	3.6	4.7	7.2	10.9	15.2	21.7	26.8	34.6	40.7	53.7	66.7	80.5	100.5	127.3	152.4	184.5	218.2	273.7
			LD	2.7	4.2	5.8	9.6	13.9	19.1	25.1	32.0	37.2	49.4	60.6	73.6	90.9	116.9	138.6	168.9	199.2	251.1
			ND	2.2	3.5	4.8	8.0	12.8	16.5	21.7	27.7	33.8	41.6	52.8	65.0	78.8	97.0	129.9	155.9	187.9	225.2
Input	Rated input current (A) *1	VLD	4.9	6.4	9.9	15.0	20.8	29.8	36.9	47.6	56.0	73.8	91.7	110.7	138.1	175.0	209.5	253.6	300.0	376.2	
		LD	3.7	5.7	8.0	13.2	19.0	26.2	34.5	44.0	51.2	67.9	83.3	101.2	125.0	160.7	190.5	232.1	273.8	345.2	
		ND	3.0	4.8	6.5	11.0	17.6	22.6	29.8	38.1	46.4	57.1	72.6	89.3	108.3	133.3	178.6	214.3	258.3	309.5	
Rated input AC voltage		Control power supply: Power supply single phase 380 to 500 V (allowable variation range 323 to 550 V), 50 Hz (allowable variation range: 47.5 to 52.5 Hz)/60 Hz (allowable variation range: 57 to 63 Hz) Main circuit power supply: 3-phase (3-wire) 380 to 500 V (allowable variation range) 323 to 550 V, 50 Hz (allowable variation range: 47.5 to 52.5 Hz)/60 Hz (allowable variation range: 57 to 63 Hz)																			
Input	Power supply equipment capacity (kVA) *2	VLD	3.7	4.9	7.5	11.4	15.9	22.7	28.1	36.3	42.6	56.3	69.9	84.4	105.2	133.4	159.7	193.2	228.6	286.7	
		LD	2.8	4.4	6.1	10.1	14.5	20.0	26.3	33.6	39.0	51.7	63.5	77.1	95.3	122.5	145.2	176.9	208.7	263.1	
		ND	2.3	3.6	5.0	8.3	13.4	17.2	22.7	29.0	35.4	43.5	55.3	68.0	82.6	101.6	136.1	163.3	196.9	235.9	
Carrier frequency range *3	VLD	0.5 to 10.0 kHz															0.5 to 8.0 kHz				
	LD	0.5 to 12.0 kHz															0.5 to 8.0 kHz				
	ND	0.5 to 16.0 kHz															0.5 to 10.0 kHz				
Motor start torque *4		200%/0.3 Hz															180%/0.3 Hz				
Braking	Regenerative braking	Equipped with braking resistance circuit (with a discharging resistor separately installed)												Regenerative braking unit separately installed							
	Minimum resistance that can be connected (Ω)	100	100	100	70	70	35	35	24	24	20	15	15	10	10	---	---	---	---		
Dimension	Height (mm)	255	255	255	255	260	260	260	390	390	390	540	550	550	550	700	700	740	740		
	Width (mm)	150	150	150	150	210	210	210	245	245	245	300	390	390	390	390	390	480	480		
	Depth (mm)	140	140	140	140	170	170	170	190	190	190	195	250	250	250	270	270	270	270		
Protection class		IP20 *5 / UL open type															IP00 / UL open type				
Approximate mass (kg)		3	3	3	3	6	6	6	8.5	8.5	8.5	22	31	31	31	41	41	53	53		

*1 The rated input currents shown in the table are the values when the rated current is output. The values vary depending on impedance on the power supply (wiring, breaker, input reactor option, etc.)

*2 The power supply equipment capacities shown in the table are the values when 220 V rated current is output. The values vary depending on impedance on the power supply (wiring, breaker, input reactor option, etc.)

*3 The setting of rated values for carrier frequencies [bb101]/[bb201] are internally limited in accordance with the description. Also, it is recommended to set values equivalent to or above (maximum output frequency for driving ×10 Hz for the setting of carrier frequencies [bb101]/[bb201]). Also, in the case of induction motor (IM) control, for items other than those subject to V/f control, it is recommended to set carrier frequency at 2 kHz or more. In the case of synchronous motor (SM)/permanent magnet motor (PMM) control, it is recommended to set carrier frequency at 8 kHz or more.

*4 The value of the sensor-less vector control applied to the ND rating in the Standard motor. Torque characteristics may vary depending on the control method and the motor used.

*5 Based on self declaration.

Dimensions

3G3RX2 inverter

3G3RX2-A2004/A2007/A2015/A2022/A2037
 3G3RX2-A4007/A4015/A4022/A4037

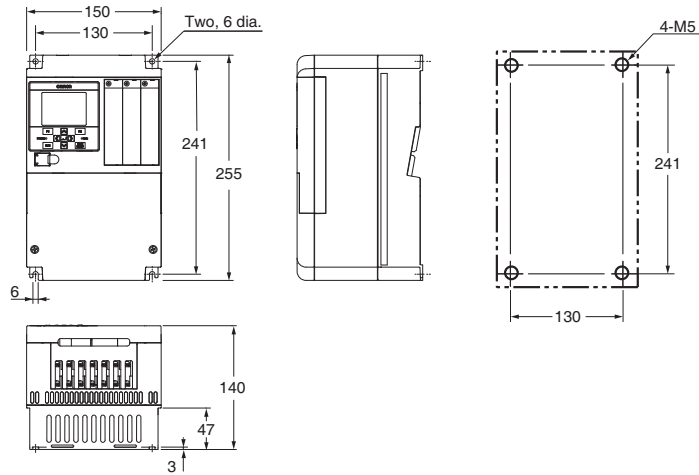

3G3RX2-A2055/A2075/A2110
 3G3RX2-A4055/A4075/A4110

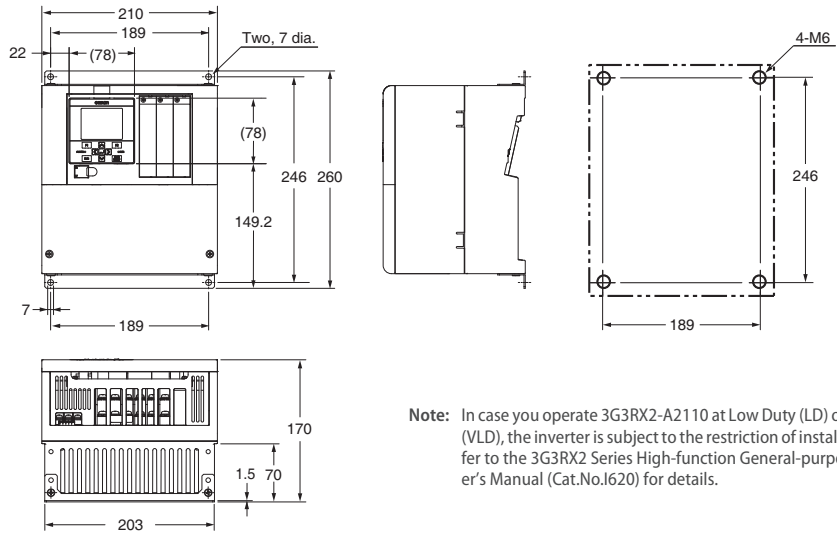

Note: In case you operate 3G3RX2-A2110 at Low Duty (LD) or Very Low Duty (VLD), the inverter is subject to the restriction of installing method. Refer to the 3G3RX2 Series High-function General-purpose Inverter User's Manual (Cat.No.I620) for details.

3G3RX2-A2150/A2185/A2220
 3G3RX2-A4150/A4185/A4220

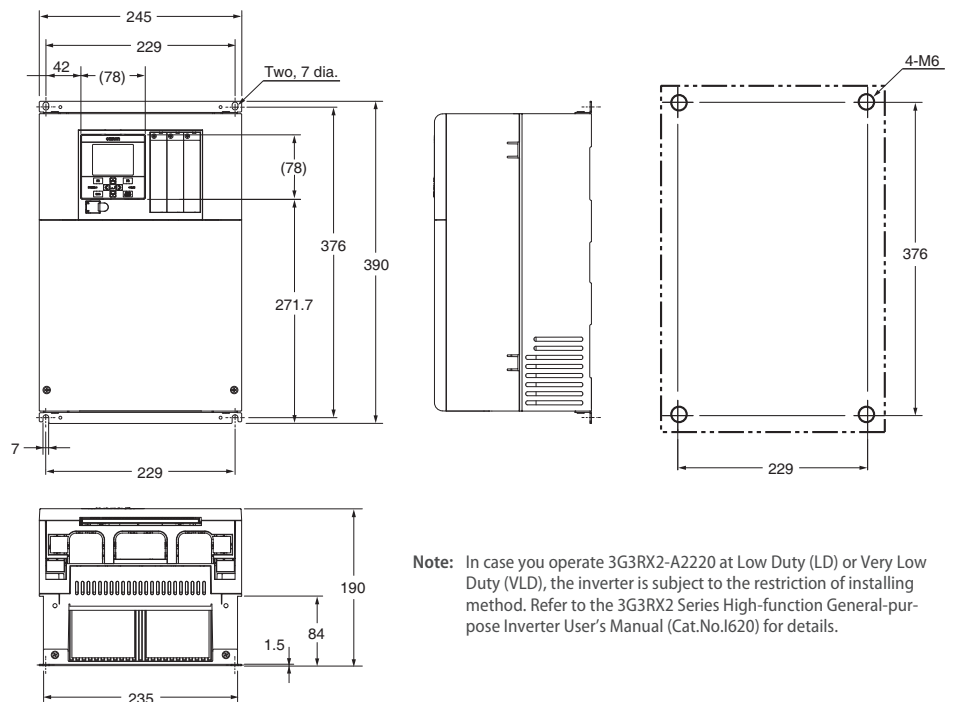

Note: In case you operate 3G3RX2-A2220 at Low Duty (LD) or Very Low Duty (VLD), the inverter is subject to the restriction of installing method. Refer to the 3G3RX2 Series High-function General-purpose Inverter User's Manual (Cat.No.I620) for details.

3G3RX2-A2300
3G3RX2-A4300

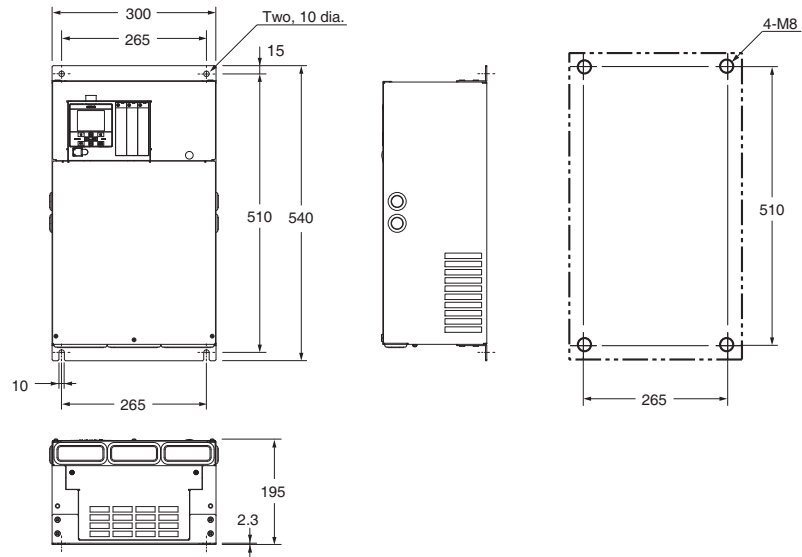

3G3RX2-A2370/A2450
3G3RX2-A4370/A4450/A4550

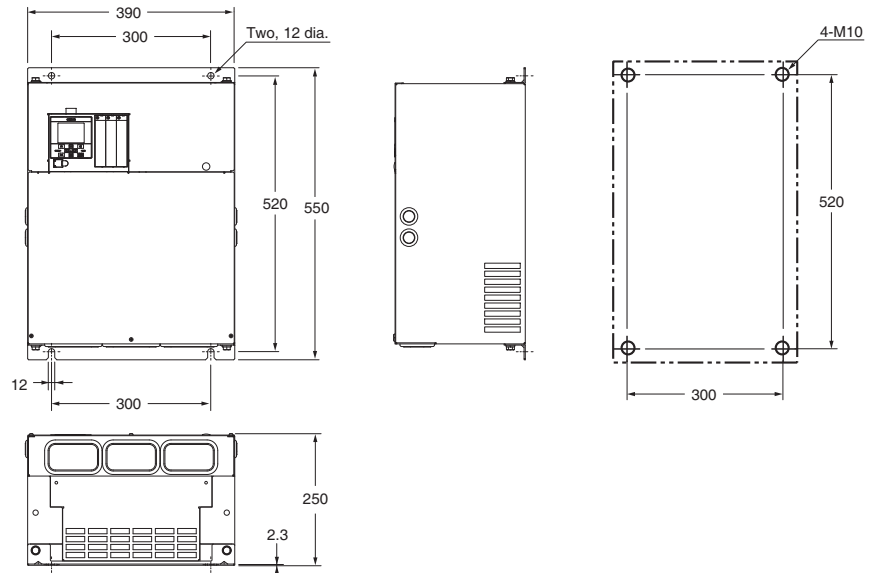

3G3RX2-A2550

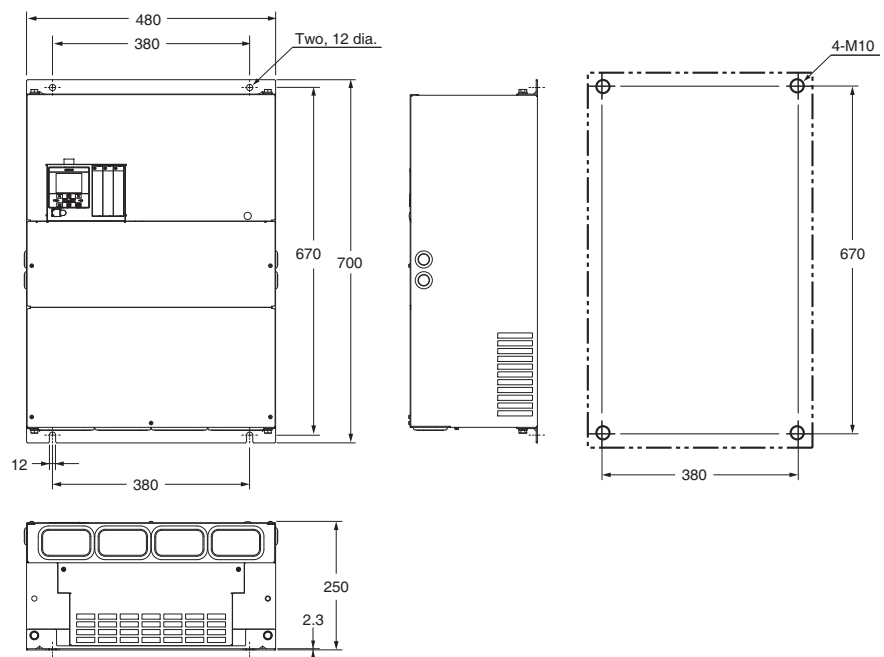

3G3RX2-B4750/B4900

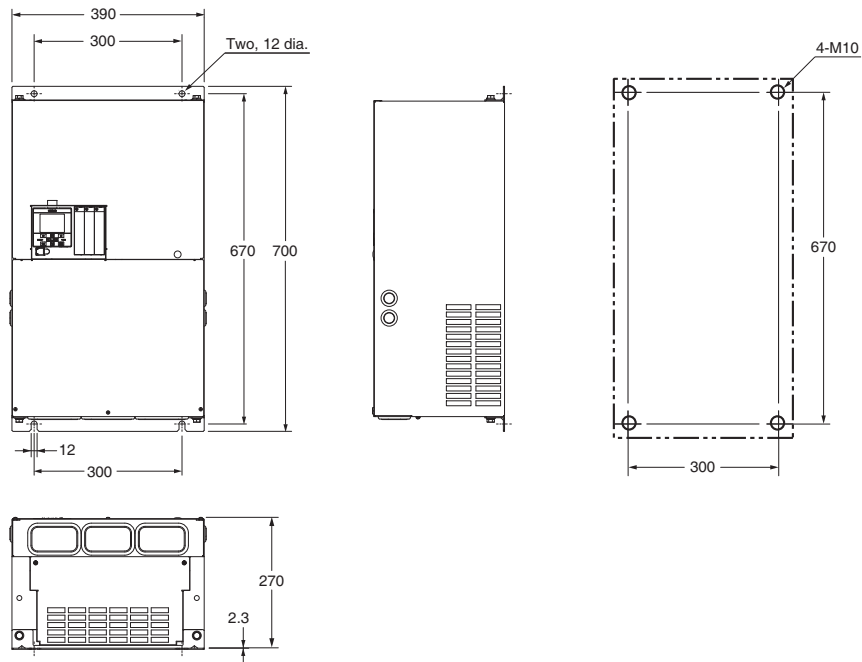

3G3RX2-B411K/B413K

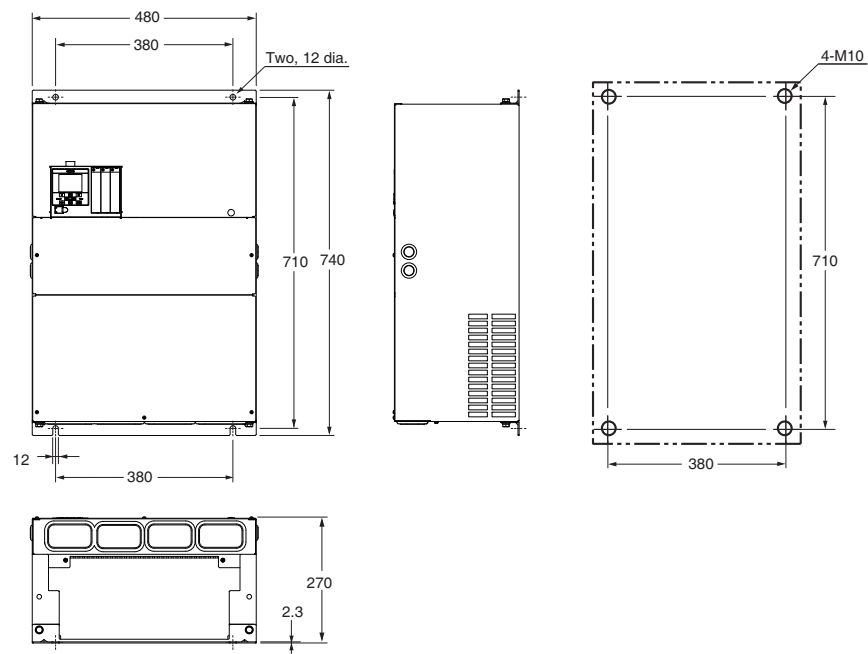

Option board

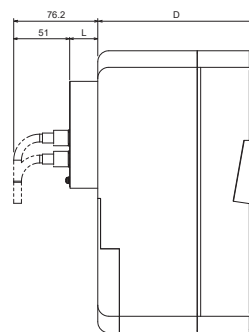

Model	L (mm)
PG speed controller (3G3AX-RX2-PG01)	47
PROFIBUS (P1-PB)	31.3
PROFINET (P1-PN)	31.3
Modbus TCP (P1-EN)	33
EtherCAT (3G3AX-RX2-ECT)	25.2

Note: The dimension D differs depending on the capacity of the inverter.

Accessories

Schaffner filters

Footprint dimensions

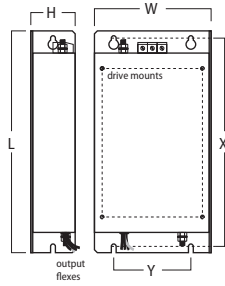

Book type dimensions

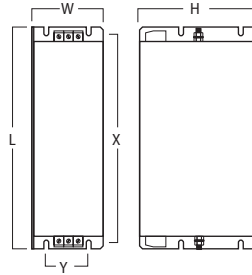

Block type dimensions

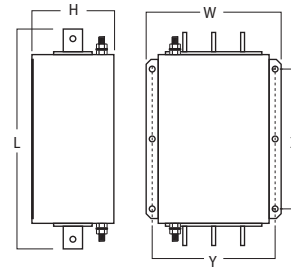

Voltage class	Inverter model	Schaffner model	Filter type	Dimensions in mm						Weight (kg)
				L	W	H	X	Y	M	
3-phase 200 V	3G3RX2-A2004	AX-FIR2021-SE	Footprint	300	152	52	284	120	M5	1.5
	3G3RX2-A2007									
	3G3RX2-A2015									
	3G3RX2-A2022									
	3G3RX2-A2037									
	3G3RX2-A2055	AX-FIR2055-SE	Footprint	306	213	56	290	170	M6	2.5
	3G3RX2-A2075									
	3G3RX2-A2110									
	3G3RX2-A2150	AX-FIR2114-SE	Footprint	436	248	90	421	200	M6	-
	3G3RX2-A2185									
	3G3RX2-A2220									
	3G3RX2-A2300	AX-FIR4146-SE	Book	310	100	225	-	70	-	6.6
	3G3RX2-A2370	AX-FIR4310-SE	Block	386	260	115	240	235	-	9.5
3G3RX2-A2450										
3G3RX2-A2550										
3-phase 400 V	3G3RX2-A4007	AX-FIR4011-SE	Footprint	300	152	52	284	120	M5	1.2
	3G3RX2-A4015									
	3G3RX2-A4022									
	3G3RX2-A4037									
	3G3RX2-A4055	AX-FIR4030-SE	Footprint	306	213	52	290	170	M6	2
	3G3RX2-A4075									
	3G3RX2-A4110									
	3G3RX2-A4150	AX-FIR4058-SE	Footprint	436	248	56	421	200	M6	3
	3G3RX2-A4185									
	3G3RX2-A4220									
	3G3RX2-A4300	AX-FIR4073-SE	Book	290	80	205	-	50	-	4.3
	3G3RX2-A4370	AX-FIR4090-SE	Book	300	90	210	-	60	-	5.1
	3G3RX2-A4450	AX-FIR4146-SE	Book	310	100	225	-	70	-	6.6
	3G3RX2-A4550									
	3G3RX2-B4750	AX-FIR4310-SE	Block	386	260	115	240	235	-	9.5
	3G3RX2-B4900									
	3G3RX2-B411K									
3G3RX2-B413K										

Input AC reactor

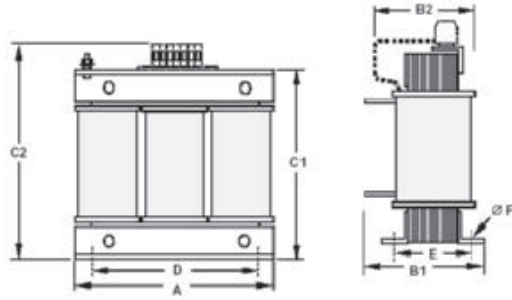

Voltage class	Reference	Dimensions in mm								Weight (kg)	
		A	B1	B2	C1	C2	D	E	F		
3-phase 200 V	AX-RAI02800080-DE	120	-	70	-	120	80	52	5.5	1.78	
	AX-RAI00880200-DE			80						2.35	
	AX-RAI00350335-DE	180	-	85	-	190	140	55	6	5.5	
	AX-RAI00180670-DE			205						6.5	
	AX-RAI00091000-DE			105		85	11.7				
	AX-RAI00071550-DE	120	-	150	-	-	-	-	-	-	-
	AX-RAI00042300-DE										
3-phase 400 V	AX-RAI07700050-DE	120	-	70	-	120	80	52	5.5	1.78	
	AX-RAI03500100-DE			80				62		2.35	
	AX-RAI01300170-DE	180	-	75	-	195	140	55	6	5.5	
	AX-RAI00740335-DE			85						190	6.5
	AX-RAI00360500-DE			105		205	11.2				
	AX-RAI00290780-DE	240	-	110	-	275	200	75	-	16.0	
	AX-RAI00191150-DE							110		200	16.0
	AX-RAI00111850-DE							110		200	16.0
	AX-RAI00072700-DE	180	-	210	-	-	-	110	-	25.4	

DC reactor

Figure 1

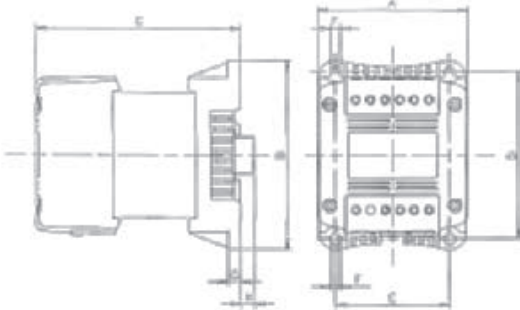
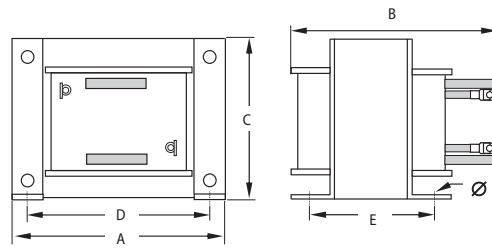

Figure 2



Voltage class	Reference	Fig	Dimensions in mm							Weight (kg)						
			A	B	C	D	E	F	G		H					
3-phase 200 V	AX-RC10700032-DE	1	84	113	96	101	66	5	7.5	2	1.22					
	AX-RC06750061-DE				105						1.60					
	AX-RC03510093-DE				116						1.95					
	AX-RC02510138-DE				124						120	82	6.5	9.5	9.5	3.20
	AX-RC01600223-DE				136						135	94	7	-	-	5.20
	AX-RC01110309-DE	146	146	115	7	-	-	6.00								
	AX-RC00840437-DE	150	177	160	160	115	-	2	-	-	11.4					
	AX-RC00590614-DE			183							14.3					
	AX-RC00440859-DE			183							14.3					
	AX-RC00301275-DE	2	195	161	163	185	88	10	-	-	17.0					
	AX-RC00231662-DE			196							123	25.0				
	AX-RC00192015-DE	240	188	200	228	109	12	-	-	-	34.0					
	AX-RC00162500-DE										208	129	42.0			
	AX-RC00133057-DE										228	149	48.0			

Voltage class	Reference	Fig	Dimensions in mm								Weight (kg)	
			A	B	C	D	E	F	G	H		
3-phase 400 V	AX-RC27000030-DE	1	84	113	105	101	66	5	7.5	2	1.60	
	AX-RC14000047-DE				116						1.95	
	AX-RC10100069-DE										3.70	
	AX-RC06400116-DE	108	135	133	120	82	6.5	9.5	9.5	3.70		
	AX-RC04410167-DE	120	152	136	135	94	7	-	-	5.20		
	AX-RC03350219-DE			146						6.00		
	AX-RC02330307-DE	150	177	160	160	115	7	2	-	11.4		
	AX-RC01750430-DE			183						14.3		
	AX-RC01200644-DE	2	195	161	163	185	88	10	-	-	17.0	
	AX-RC00920797-DE			196							25.5	
	AX-RC00741042-DE	240	188	200	228	109	12	-	-	-	34.0	
	AX-RC00611236-DE										198	38.0
	AX-RC00501529-DE										228	48.0
	AX-RC00372094-DE	300	230	256	250	160	-	-	-	-	49.0	
	AX-RC00312446-DE										245	52.5
	AX-RC00252981-DE										250	79.0
	AX-RC00213613-DE					180						

Output AC reactor

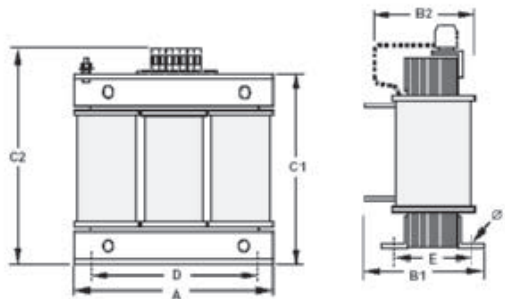

Voltage class	Reference	Dimensions in mm								Weight (kg)
		A	B1	B2	C1	C2	D	E	F	
3-phase 200 V	AX-RAO11500026-DE	120	-	70	-	120	80	52	5.5	1.78
	AX-RAO07600042-DE	120	-	70	-	120	80	52	5.5	1.78
	AX-RAO04100075-DE	120	-	80	-	120	80	62	5.5	2.35
	AX-RAO03000105-DE	120	-	80	-	120	80	62	5.5	2.35
	AX-RAO01830160-DE	180	-	85	-	195	140	55	6	5.5
	AX-RAO01150220-DE	180	-	85	-	195	140	55	6	5.5
	AX-RAO00950320-DE	180	-	85	-	210	140	55	6	6.5
	AX-RAO00630430-DE	180	-	95	-	210	140	65	6	9.1
	AX-RAO00490640-DE	180	-	105	-	210	140	75	6	11.7
	AX-RAO00390800-DE	240	-	110	-	275	200	75	6	16.0
	AX-RAO00330950-DE	240	-	110	-	275	200	75	6	16.0
	AX-RAO00251210-DE	240	-	110	-	300	200	75	6	16.0
	AX-RAO00191450-DE	240	130	-	215	-	200	85	6	18.6
	AX-RAO00161820-DE	240	160	-	215	-	200	110	6	27.0
	AX-RAO00132200-DE	300	165	-	300	-	200	125	6	33.5

Voltage class	Reference	Dimensions in mm								
		A	B1	B2	C1	C2	D	E	F	Weight (kg)
3-phase 400 V	AX-RAO16300038-DE	120	-	80	-	120	80	62	5.5	2.35
	AX-RAO11800053-DE	120	-	80	-	120	80	62	5.5	2.35
	AX-RAO07300080-DE	180	-	85	-	195	140	55	6	5.5
	AX-RAO04600110-DE	180	-	85	-	195	140	55	6	5.5
	AX-RAO03600160-DE	180	-	85	-	210	140	55	6	6.5
	AX-RAO02500220-DE	180	-	95	-	210	140	65	6	9.1
	AX-RAO02000320-DE	240	-	110	-	275	200	75	6	16.0
	AX-RAO01650400-DE	240	-	110	-	275	200	75	6	16.0
	AX-RAO01300480-DE	240	-	110	-	275	200	75	6	16.0
	AX-RAO01030580-DE	240	-	110	-	281	200	75	6	16.0
	AX-RAO00800750-DE	240	-	120	-	281	200	85	6	18.6
	AX-RAO00680900-DE	240	-	150	-	281	200	110	6	27.0
	AX-RAO00531100-DE	300	-	125	-	350	200	105	6	27.9
	AX-RAO00401490-DE	300	170	-	270	-	200	125	6	44.0
	AX-RAO00331760-DE	300	170	-	270	-	200	125	6	44.0
	AX-RAO00262170-DE	360	230	-	315	-	300	150	8	55.0
AX-RAO00212600-DE	420	240	-	370	-	300	150	8	75.0	

Chokes

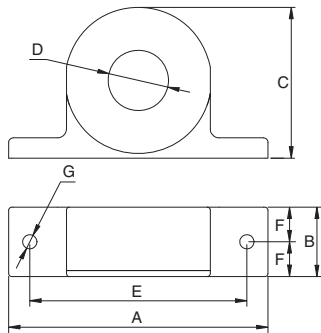

Figure 1

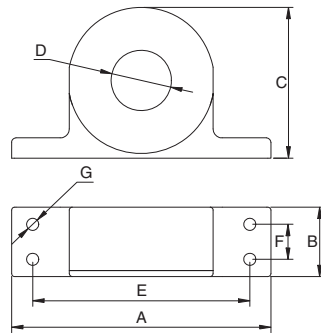

Figure 2

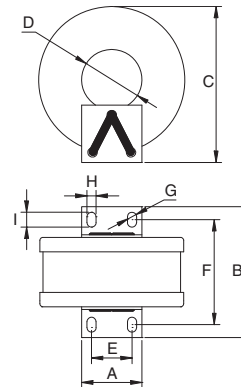

Figure 3

Reference	Fig	D (diameter)	Motor (kW)	Dimensions (mm)								Weight (kg)	
				A	B	C	D	E	F	G (diameter)	H		I
AX-FER2102-PE	1	21	< 2.2	86	24	50	21	70	12	4	-	-	0.09
AX-FER2815-PE		28	< 15	106	25	65	28	90	12.5	-	-	0.22	
AX-FER5045-PE	2	50	< 45	150	51	112	50	125	30	5	-	-	0.53
AX-FER5255-PE	3	52	≥ 55	47	75.5	110	52	30	58.5	-	5	7	1.20

DC Supply with Regenerative Active Front End
Regenerative DC bus supply

Figure 1

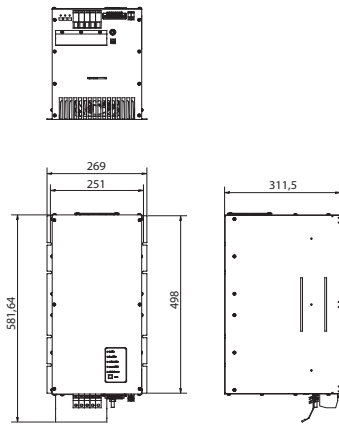

Figure 2

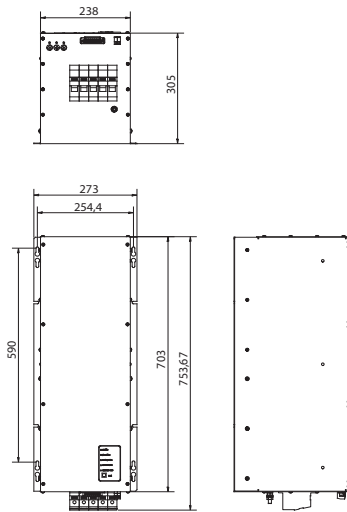
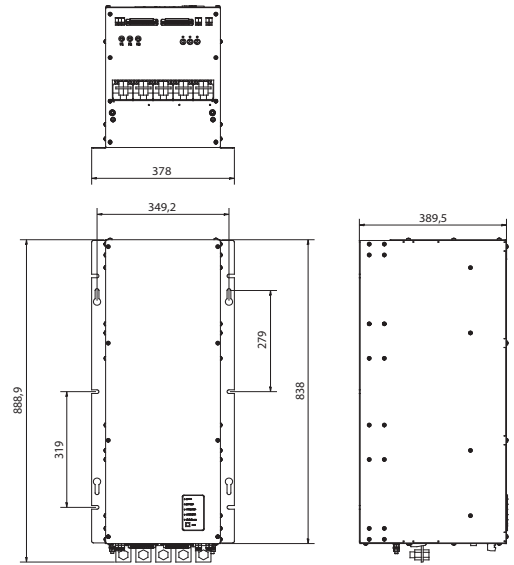
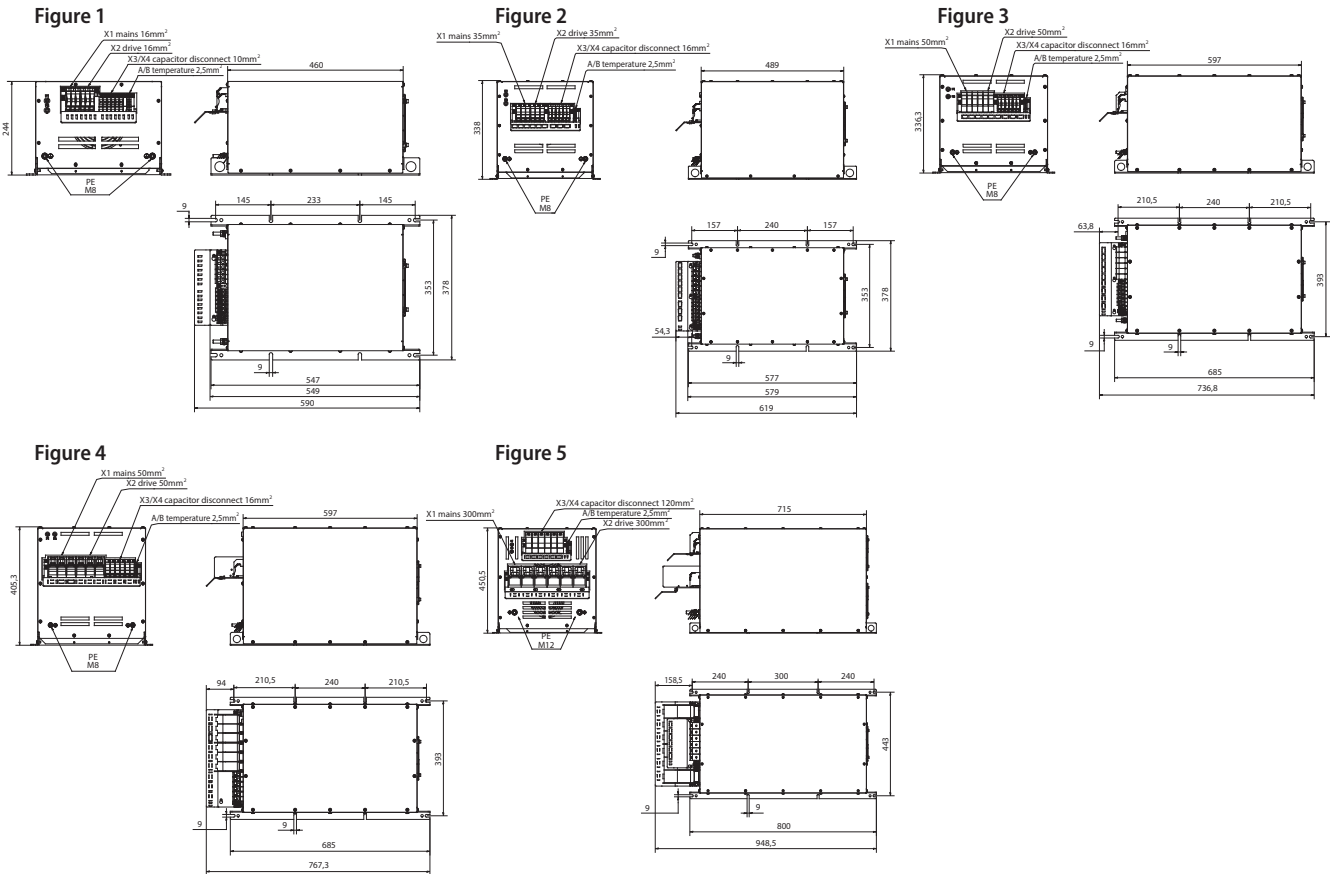

Figure 3



Reference	Fig	Weight (kg)
RFE-B3 30-400-50-230-A-RVE	1	37
RFE-B3 45-400-50-230-A-RVE		38
RFE-B3 60-400-50-230-A-RVE	2	45
RFE-B3 80-400-50-230-A-RVE		52
RFE-B3 100-400-50-230-A-RVE		65
RFE-B3 125-400-50-230-A-RVE	3	87
RFE-B3 150-400-50-230-A-RVE		89
RFE-B3 200-400-50-230-A-RVE		100

Low harmonic filter



Reference	Fig	Weight (kg)
RHF-RA 43-400-50-20-A-RVE	1	39
RHF-RA 72-400-50-20-A-RV	2	56
RHF-RA 86-400-50-20-A-RVE	3	62
RHF-RA 144-400-50-20-A-RVE	4	85
RHF-RA 180-400-50-20-A-RVE	5	102
RHF-RA 217-400-50-20-A-RVE		119
RHF-RA 304-400-50-20-A-RVE		142

EMC filter

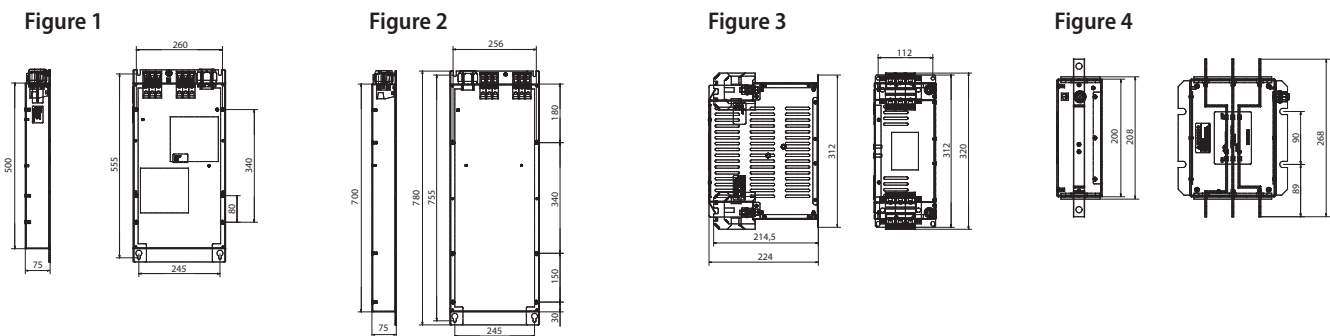

Reference	Fig	Filter type	Weight (kg)
RFI-RA 12-RVE	1	Footprint	11,1
RFI-RA 23-RVE	2		15,1
RFI-RA X5-RVE	3	Book	4,9
RFI-RA X6-RVE	4	Block	3,9

Regenerative Braking unit

Figure 1

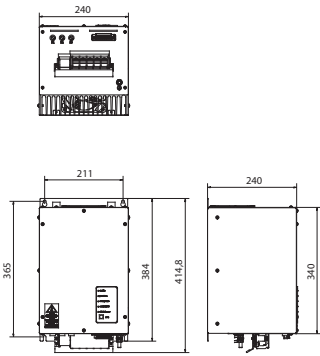

Figure 2

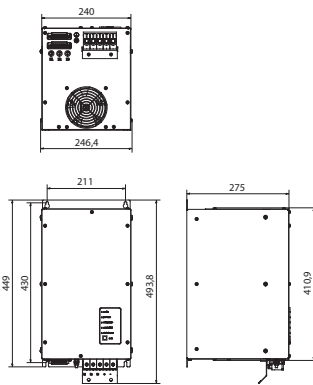

Figure 3

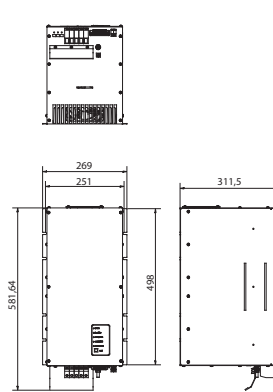

Figure 4

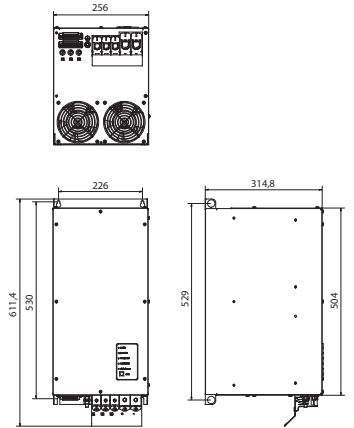

Figure 5

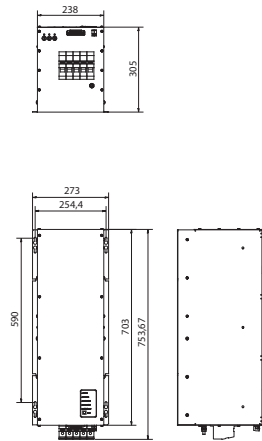

Figure 6

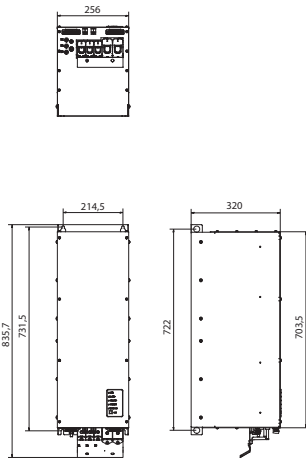
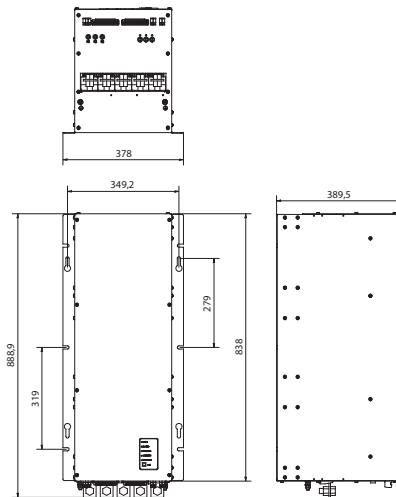

Figure 7



Models for Low Duty applications (50%)	Fig	Weight (kg)	Models for High Duty applications	Fig	Weight (kg)
RLD-E0 8-400-50-0-A-RVE	1	16	RHD-B0 7-400-50-0-A-RVE	1	17
RLD-E0 12-400-50-0-A-RVE		17	RHD-B0 13-400-50-0-A-RVE		18
RLD-E0 16-400-50-0-A-RVE		18	RHD-B0 18-400-50-0-A-RVE		20
RLD-E0 20-400-50-0-A-RVE	2	22	RHD-B0 24-400-50-0-A-RVE	3	32,5
RLD-E0 24-400-50-0-A-RVE			RHD-B0 30-400-50-230-A-RVE		
RLD-E0 32-400-50-0-A-RVE			RHD-B0 50-400-50-230-A-RVE		
RLD-E0 40-400-50-0-A-RVE	4	23	RHD-B0 70-400-50-230-A-RVE	5	40
RLD-E0 48-400-50-0-A-RVE		27	RHD-B0 100-400-50-230-A-RVE		51
RLD-E0 58-400-50-0-A-RVE		28	RHD-B0 125-400-50-230-A-RVE		85
RLD-E0 80-400-50-0-A-RVE	6	30	RHD-B0 150-400-50-230-A-RVE	7	91
RLD-E0 95-400-50-0-A-RVE		35			100
RLD-E0 116-400-50-0-A-RVE		38			
RLD-E0 140-400-50-0-A-RVE	6	52			
RLD-E0 170-400-50-230-A-RVE		60			
RLD-E0 200-400-50-230-A-RVE		68			

Braking unit

Reference	Dimensions in mm					
	B	B1	H	H1	T	S
AX-BCR4015045-TE	82.5	40.5	150	138	220	6
AX-BCR4017068-TE						
AX-BCR2035090-TE	130	64.5	205	193	208	6
AX-BCR2070130-TE						
AX-BCR4035090-TE						
AX-BCR4070130-TE						
AX-BCR4090240-TE	131	64.5	298	280	300	9

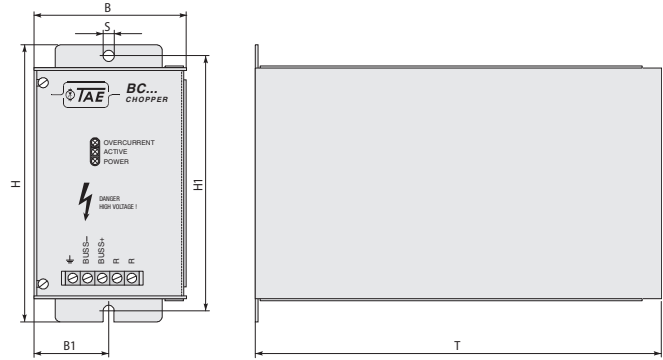

Resistor

AX-REM00K15xxx

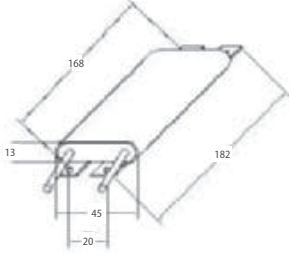

Fig 3

Fig 1

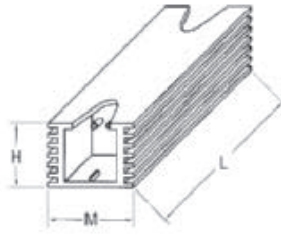

Fig 4

Fig 2

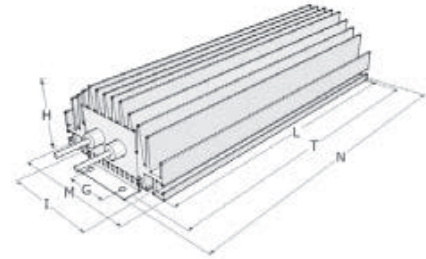
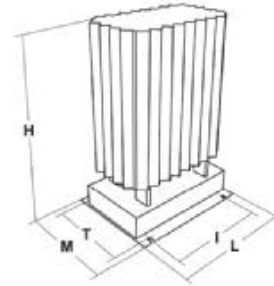
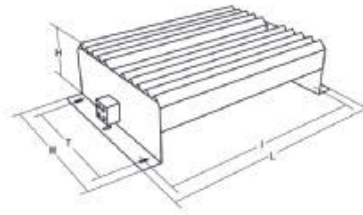
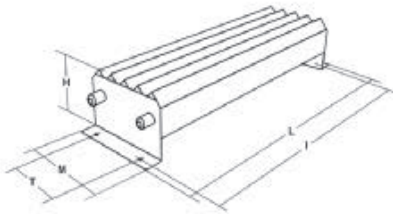

Fig 5



Reference	Fig	Dimensions in mm								Weight (kg)
		L	H	M	I	T	G	N		
AX-REM00K2070-IE	1	105	27	36	94	-	-	-	0.2	
AX-REM00K2120-IE										
AX-REM00K2200-IE										
AX-REM00K4075-IE		200	27	36	189	-	-	-	0.425	
AX-REM00K4035-IE										
AX-REM00K4030-IE										
AX-REM00K5120-IE		260	27	36	249	-	-	-	0.58	
AX-REM00K6100-IE	320	27	36	309	-	-	-	0.73		
AX-REM00K6035-IE										
AX-REM00K9070-IE	2	200	61	100	74.5	216	40	230	1.41	
AX-REM00K9020-IE										
AX-REM00K9017-IE										
AX-REM01K9070-IE	3	365	73	105	350	70	-	-	4	
AX-REM01K9017-IE										
AX-REM02K1070-IE	4	310	100	240	295	210	-	-	7	
AX-REM02K1017-IE										
AX-REM03K5035-IE		365	100	240	350	210	-	-	8	
AX-REM03K5010-IE										
AX-REM19K0006-IE	5	206	350	140	190	50	-	-	8.1	
AX-REM19K0008-IE										
AX-REM19K0020-IE										
AX-REM19K0030-IE										
AX-REM38K0012-IE		306	350	140	290	50	-	-	14.5	

Installation

Terminal connections

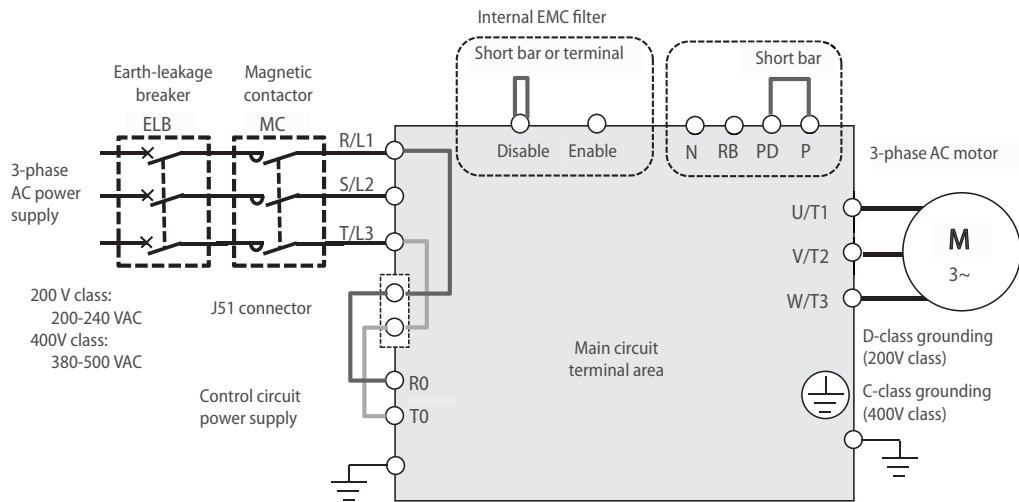

Terminal	Name	Function (signal level)
R/L1, S/L2, T/L3	Main circuit power supply input	Used to connect the AC power supply
U/T1, V/T2, W/T3	Inverter output terminal	Used to connect the 3-phase motor
PD/+1, P/+	External DC reactor terminal	Remove the short bar between PD and P terminals, and connect the optional reactor DCL for improving power factor
P/+, RB	Braking resistor connection terminal	Connect option braking resistor (if a braking torque is required)
P/+, N/-	Regenerative braking unit connection terminal	Connect optional regenerative braking units
PE	Grounding	The earth terminal for the Inverter case. Please connect this terminal to the ground Conduct class-D ground work for 200 V class, and class-C ground work for 400 V class

Control circuit

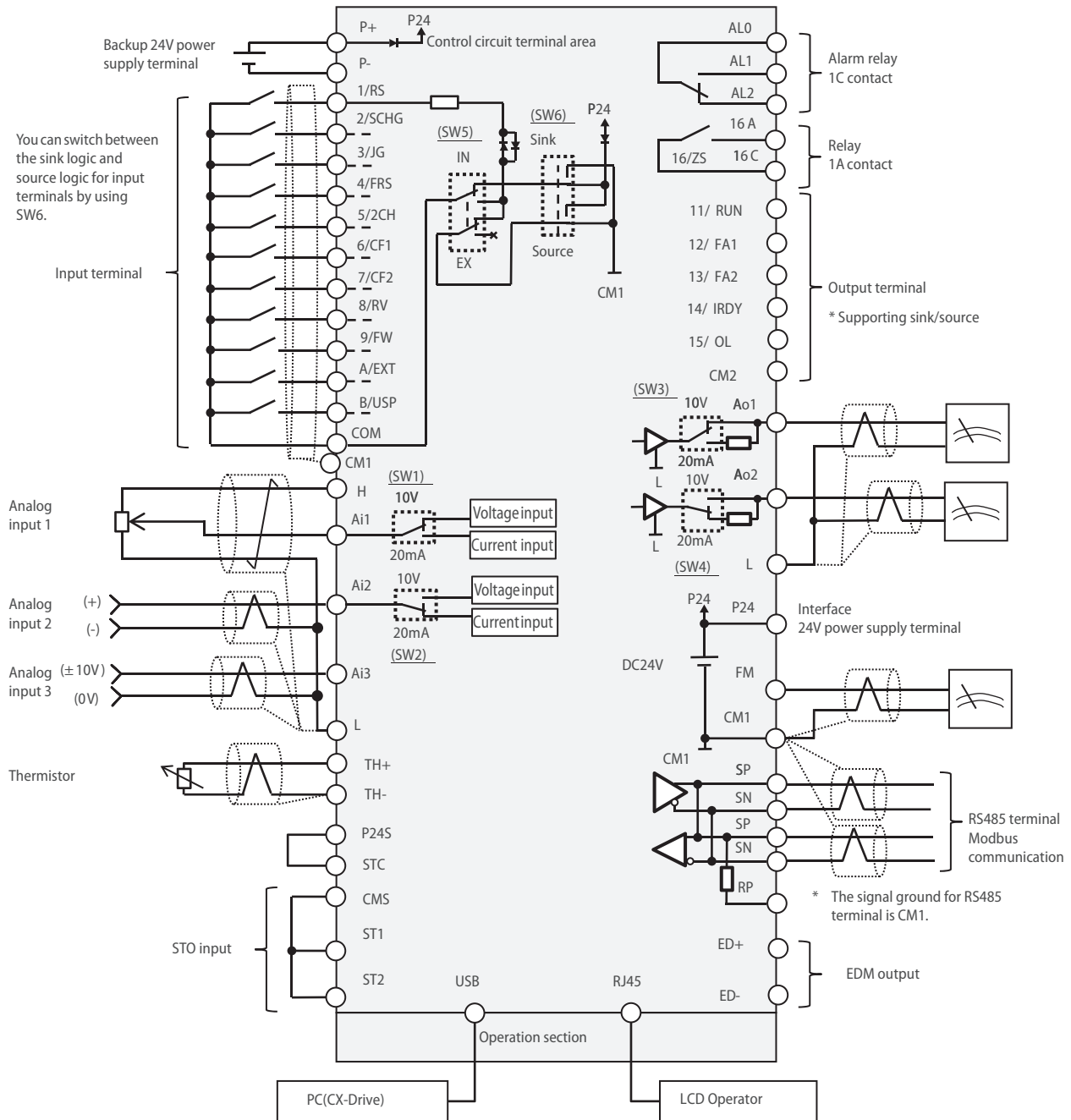

		Terminal symbol	Terminal name	Description	Electrical characteristics	
Input terminal	Digital input	Contact	9, 8, 7, 6, 5, 4, 3, 2, 1	Input terminal	You can select terminal functions using the parameter settings corresponding to each terminal. You can switch between the sink logic and source logic by switching SINK/SRC of SW6.	Voltage between each input/COM <ul style="list-style-type: none"> • ON voltage Min. DC18V • OFF voltage Max. DC3V • Maximum allowable voltage DC27V • Load current 5.6mA (at DC27V)
		Contact/pulse	A	Pulse input-A	When (CA-90) is set to 00, A, and B terminals can be used as input terminals.	Voltage between each input/COM <ul style="list-style-type: none"> • ON voltage Min. DC18V • OFF voltage Max. DC3V • Maximum allowable voltage DC27V • Load current 5.6mA (at DC27V) • Maximum 32kpps pulse input
			B	Pulse input-B	You can select terminal functions using the parameter settings corresponding to each terminal. When (CA-90) is not set to 00, they are used as terminals for pulse string input. The maximum input pulse is 32kpps.	
		Common	COM	Common for input terminal	Common terminals for digital input terminals (1, 2, 3, 4, 5, 6, 7, 8, 9, A, B). There are three COM terminals	

			Terminal symbol	Terminal name	Description	Electrical characteristics
Output terminal	Digital output	Open collector	15, 14, 13, 12, 11	Output terminal	You can select terminal functions using the parameter settings corresponding to each terminal. These terminals can be used both in sink logic or source logic	Open collector output <ul style="list-style-type: none"> Between each terminal and CM2 Voltage drop at ON: 4V or below Maximum allowable voltage: 27V Maximum allowable current: 50mA
			CM2	Common for output terminal	Common terminals for output terminals 11-15	
		Relay	16A 16C	1a relay terminal	A relay for contact A output.	Maximum capacity of contact <ul style="list-style-type: none"> AC250V, 2A (resistance)/AC250V, 1A (induction) Minimum capacity of contact <ul style="list-style-type: none"> DC1V, 1mA
			AL0 AL1 AL2	1c relay terminal	A relay for contact C output.	Maximum capacity of contact AL1/AL0: <ul style="list-style-type: none"> AC250V, 2A (resistance)/AC250V, 0.2A (induction) AL2/AL0: <ul style="list-style-type: none"> AC250V, 1A (resistance)/AC250V, 0.2A (induction) Minimum capacity of contact (common) <ul style="list-style-type: none"> AC100V, 10mA/DC5V, 100mA
		Monitor output	FM	Digital monitor (voltage)	For digital monitor output, you can choose the PWM output method at 6.4 ms interval or pulse output method with about 50% duty in which frequency varies.	Pulse string output DC0-10V <ul style="list-style-type: none"> Maximum allowable current 1.2 mA Maximum frequency 3.60 kHz
			CM1	Common for digital monitor	The common terminal for digital monitor	
Analog input terminal for switching voltage and current	Power supply	L	Analog power common	Common terminals for analog input terminals (Ai1, Ai2, Ai3) and analog output terminals (Ao1, Ao2). There are two L terminals		
		H	Power supply for setting speed	This is a 10V VDC power supply. It is used when using analog input terminals (Ai1, Ai2, Ai3) and variable resistor for inputting voltage	Maximum allowable input current 20mA	
	Analog input	Ai1	Analog input terminal 1 (voltage /current switching SW1)	For Ai1 and Ai2, 0-10 VDC voltage input and 0-20 mA current input can be switched using a switch for use. It can be used for input frequency command or feedback	In the case of voltage input: <ul style="list-style-type: none"> Input impedance about 10kΩ Allowable input voltage -0.3 to 12V In the case of current input: <ul style="list-style-type: none"> Input impedance about 100Ω Maximum allowable input current 24 mA 	
		Ai2	Analog input terminal 2 (voltage /current switching SW2)			
		Ai3	Analog input terminal 3	-10 to 10 VDC voltage input is available. It can be used for input frequency command or feedback.	Only voltage input: <ul style="list-style-type: none"> Input impedance about 10 kΩ Allowable voltage input -12 to 12VDC 	
	Analog output	Ao1	Analog output terminal 1 (voltage /current switching SW3)	For Ao1 and Ao2. 0-10 VDC voltage output and 0-20 mA current output can be switched using a switch as output of information monitor data of the inverter.	In the case of voltage output: <ul style="list-style-type: none"> Maximum allowable output current 2mA Output voltage accuracy $\pm 10\%$ (Ambient temperature: 25$\pm 10^{\circ}\text{C}$) In the case of current input: <ul style="list-style-type: none"> Allowable load impedance 250Ω or below Output current accuracy: $\pm 20\%$ (Ambient temperature: 25$\pm 10^{\circ}\text{C}$) 	
Ao2		Analog output terminal 2 (voltage /current switching SW4)				
Thermistor terminal	Analog input	TH+	External thermistor input	When an external thermistor is connected, and resistance abnormality occurs due to abnormal temperature, etc., trip the inverter. Connect the thermistor with TH+ and TH-. The level of detecting resistance abnormality can be adjusted from 0 to 10000Ω. [Recommended thermistor characteristics] Recommended product SHIBAURA ELECTRONICS Co., Ltd. PB41 E Allowable rated power: 100mW or more Impedance at abnormal temperature: 3kΩ	0 to 5VDC [Input circuit]	
		TH-	Common for external thermistor			
RS485 communication	Serial communication	SP SN RP (CM1)	RS-485 terminal for Modbus communication	SP terminal: RS-485 differential (+) signal SN terminal: RS-485 differential (-) signal RP terminal: Connect to SP via the terminating resistor CM1 terminal: Connect with the signal ground of an external communication device. (also used by FM terminal) There are two SP terminals and SN terminals each, which are connected internally. Maximum baud rate is 115.2 kps.	Equipped with terminating resistor (120Ω) Enable: Short RP-SN Disable: Open RP-SN	
24V power supply	Power input	P24	24V output power terminal	24 VDC power supply for contact signal. The common terminal is P--.	100 mA output at maximum	
		P+	External 24V input terminal (24V)	Input an external 24 VDC power to the inverter. With input of 24 V power, you can change parameter settings or operate optional communication without using a control power supply	Allowable input voltage 24 VDC $\pm 10\%$ Maximum power consumption 1 A	
		P-	Terminal for P24/P+ (0 (zero) V)			

	Terminal symbol	Terminal name	Description	Electrical characteristics
STO	P24S	24V output power terminal	24-VDC power supply for contact signals dedicated for ST1/ST2 terminal. Common is CMS.	Maximum output current is 100 mA
	CMS	Common terminal for STO terminal	Common terminal of 24-VDC power supply for contact signals dedicated for ST1/ST2 terminal	
	STC	Logic switching terminal	This is a STO Input logic switching terminal. The Input logic can be changed by changing the position of short bar. In case of using external power supply, remove short bars and then it is used as ST1/ST2 input common.	<at sink logic> Short bar: connect between P24S and STC. <at source logic> Short bars: connect between CMS and STC.
	ST1/ST2	STO input terminal	Input terminal of STO	Voltage between ST1-STC/ST2-STC <ul style="list-style-type: none"> ON voltage 15 VDC min. OFF voltage 5 VDC max Maximum allowable voltage 27VDC Load current 5.8 mA (at 27 VDC) Internal resistance: 4.7 kΩ
	ED+ ED-	Monitoring output	+ side terminal of EDM signal (STO status monitor) - side terminal of EDM signal (STO status monitor)	Open collector output <ul style="list-style-type: none"> Between ED+/ED- Voltage depression 4 V or below at ON Maximum allowable voltage 27 V Maximum allowable current 50 mA

Inverter heat loss

Voltage	Loss at 100% load (W)					
	200 V			400 V		
	ND	LD	VLD	ND	LD	VLD
0.4	50	53	65			
0.75	65	80	105	62	67	76
1.5	93	118	135	94	98	104
2.2	142	162	197	96	107	134
3.7	225	253	314	145	163	189
5.5	348	365	420	235	260	290
7.5	376	400	520	240	280	306
11	498	625	754	260	306	380
15	742	922	1059	361	444	482
18.5	964	1167	1332	495	601	633
22	1163	1263	1377	687	805	860
30	1317	1536	1698	783	854	920
37	1534	1801	2092	812	880	971
45	1625	1940	2300	1047	1218	1300
55	1878	2669	3046	1130	1488	1592
75				1570	1811	2020
90				2034	2150	2359
110				2219	2397	2557
132				3872	4352	4598

Input AC reactor

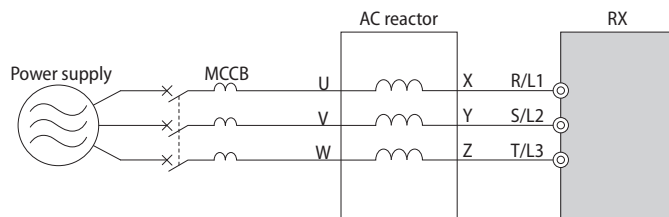

3-phase 200 V				3-phase 400 V			
Max. applicable motor output kW	Reference	Current value A	Inductance mH	Max. applicable motor output kW	Reference	Current value A	Inductance mH
0.4 to 1.5	AX-RAI02800080-DE	8.0	2.8	0.75 to 1.5	AX-RAI07700050-DE	5.0	7.7
2.2 to 3.7	AX-RAI00880200-DE	20.0	0.88	2.2 to 4.0	AX-RAI03500100-DE	10.0	3.5
5.5 to 7.5	AX-RAI00350335-DE	33.5	0.35	5.5 to 7.5	AX-RAI01300170-DE	17.0	1.3
11.0 to 15.0	AX-RAI00180670-DE	67.0	0.18	11.0 to 15.0	AX-RAI00740335-DE	33.5	0.74
18.5 to 22.0	AX-RAI00091000-DE	100.0	0.09	18.5 to 22.0	AX-RAI00360500-DE	50.0	0.36
30.0 to 37.0	AX-RAI00071550-DE	155.0	0.07	30.0 to 37.0	AX-RAI00290780-DE	78.0	0.29
45.0 to 55.0	AX-RAI00042300-DE	230.0	0.04	45.0 to 55.0	AX-RAI00191150-DE	115.0	0.19
				75.0 to 90.0	AX-RAI00111850-DE	185.0	0.11
				110.0 to 132.0	AX-RAI00072700-DE	270.0	0.07

DC reactor

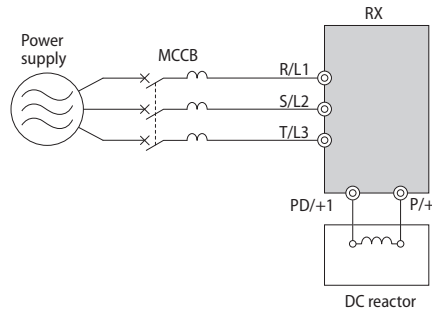

3-phase 200 V				3-phase 400 V			
Max. applicable motor output kW	Reference	Current value A	Inductance mH	Max. applicable motor output kW	Reference	Current value A	Inductance mH
0.4	AX-RC10700032-DE	3.2	10.70	0.75	AX-RC27000030-DE	3.0	27.00
0.7	AX-RC06750061-DE	6.1	6.75	1.5	AX-RC14000047-DE	4.7	14.00
1.5	AX-RC03510093-DE	9.3	3.51	2.2	AX-RC10100069-DE	6.9	10.10
2.2	AX-RC02510138-DE	13.8	2.51	4.0	AX-RC06400116-DE	11.6	6.40
3.7	AX-RC01600223-DE	22.3	1.60	5.5	AX-RC04410167-DE	16.7	4.41
5.5	AX-RC01110309-DE	30.9	1.11	7.5	AX-RC03350219-DE	21.9	3.35
7.5	AX-RC00840437-DE	43.7	0.84	11.0	AX-RC02330307-DE	30.7	2.33
11.0	AX-RC00590614-DE	61.4	0.59	15.0	AX-RC01750430-DE	43.0	1.75
15.0	AX-RC00440859-DE	85.9	0.44	18.5 to 22	AX-RC01200644-DE	64.4	1.20
18.5 to 22	AX-RC00301275-DE	127.5	0.30	30	AX-RC00920797-DE	79.7	0.92
30	AX-RC00231662-DE	166.2	0.23	37	AX-RC00741042-DE	104.2	0.74
37	AX-RC00192015-DE	201.5	0.19	45	AX-RC00611236-DE	123.6	0.61
45	AX-RC00162500-DE	250.0	0.16	55	AX-RC00501529-DE	152.9	0.50
55	AX-RC00133057-DE	305.7	0.13	75	AX-RC00372094-DE	209.4	0.37
				90	AX-RC00312446-DE	244.6	0.31
				110	AX-RC00252981-DE	298.1	0.25
				132	AX-RC00213613-DE	361.3	0.21

Output AC reactor

3-phase 200 V				3-phase 400 V			
Max. applicable motor output kW	Reference	Current value A	Inductance mH	Max. applicable motor output kW	Reference	Current value A	Inductance mH
0.4	AX-RAO11500026-DE	2.6	11.50	0.75 to 1.5	AX-RAO16300038-DE	3.8	16.30
0.75	AX-RAO07600042-DE	4.2	7.60	2.2	AX-RAO11800053-DE	5.3	11.80
1.5	AX-RAO04100075-DE	7.5	4.10	4.0	AX-RAO07300080-DE	8.0	7.30
2.2	AX-RAO03000105-DE	10.5	3.00	5.5	AX-RAO04600110-DE	11.0	4.60
3.7	AX-RAO01830160-DE	16.0	1.83	7.5	AX-RAO03600160-DE	16.0	3.60
5.5	AX-RAO01150220-DE	22.0	1.15	11	AX-RAO02500220-DE	22.0	2.50
7.5	AX-RAO00950320-DE	32.0	0.95	15	AX-RAO02000320-DE	32.0	2.00
11	AX-RAO00630430-DE	43.0	0.63	18.5	AX-RAO01650400-DE	40.0	1.65
15	AX-RAO00490640-DE	64.0	0.49	22	AX-RAO01300480-DE	48.0	1.30
18.5	AX-RAO00390800-DE	80.0	0.39	30	AX-RAO01030580-DE	58.0	1.03
22	AX-RAO00330950-DE	95.0	0.33	37	AX-RAO00800750-DE	75.0	0.80
30	AX-RAO00251210-DE	121.0	0.25	45	AX-RAO00680900-DE	90.0	0.68
37	AX-RAO00191450-DE	145.0	0.19	55	AX-RAO00531100-DE	110.0	0.53
45	AX-RAO00161820-DE	182.0	0.16	75	AX-RAO00401490-DE	149.0	0.40
55	AX-RAO00132200-DE	220.0	0.13	90	AX-RAO00331760-DE	176.0	0.33
				110	AX-RAO00262170-DE	217.0	0.26
				132	AX-RAO00212600-DE	260.0	0.21

Braking unit

Voltage	Reference	Specifications				
		Permanent		Peak (5 s max)		Minimum connectable resistor (Ohms)
		Current value A	Brake power kVA	Current value A	Brake power kVA	
3-phase 200 V	AX-BCR2035090-TE	35	13	90	32	4
	AX-BCR2070130-TE	70	25	130	47	2.8
3-phase 400 V	AX-BCR4015045-TE	15	11	45	33	16
	AX-BCR4017068-TE	17	13	68	51	11
	AX-BCR4035090-TE	35	26	90	67	8.5
	AX-BCR4070130-TE	70	52	130	97	5.5
	AX-BCR4090240-TE	90	67	240	180	3.2

DC Supply with Regenerative Active Front End system

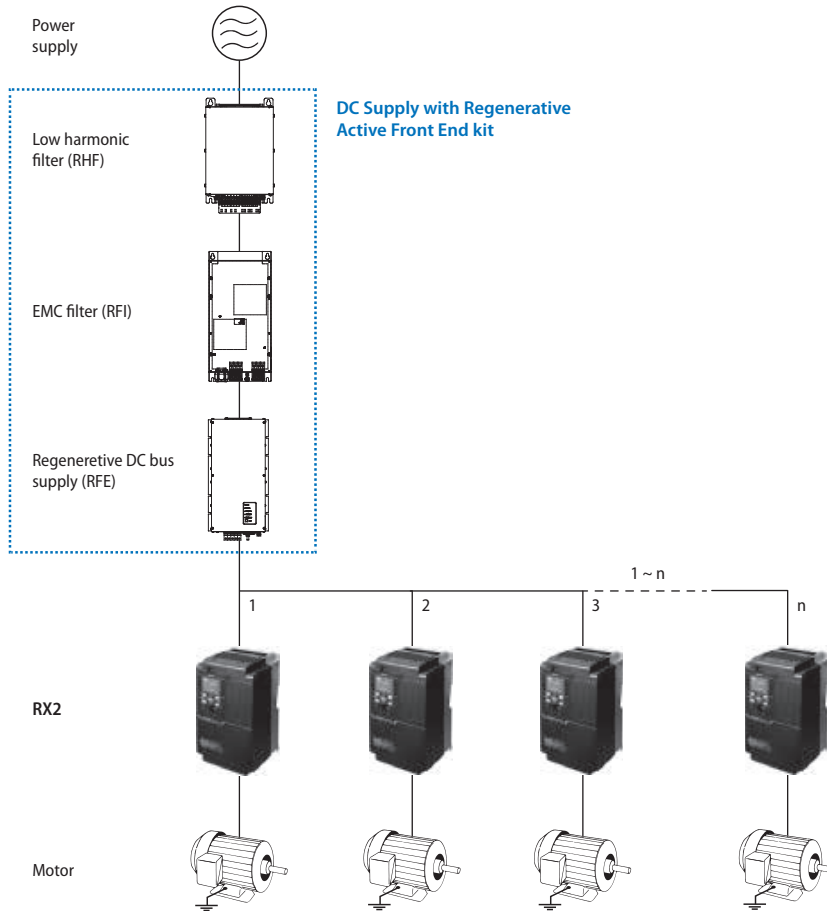

Regenerative DC bus supply

Reference: RFE-B3	30	45	60	80	100	125	150	200		
Max. input power kW	30	45	60	80	100	125	150	200		
DC capacity μF	100		220			440		660		
Max. input current A ^{*1}	Driving	AC	65	98	130	173	217	271	325	433
		DC	78	118	156	208	260	325	390	520
	Braking	AC	52	78	104	139	173	217	260	346
		DC	62	97	125	167	208	260	312	415
Rated input voltage	3-phase 400 V									
Allowable voltage fluctuation	-15% to 10%									
Mains frequency	40 to 60 Hz									
Efficiency η	98%									
Degree of protection	IP20									
Ambient humidity	85% RH or less (without condensation)									
Storage temperature	-25 to 55°C									
Ambient temperature	5 to 40°C									

*1 At nominal voltage 400 V. 1 min in 10 min.

Low harmonic filter

Reference: RHF-RA	43	72	86	144	180	217	304	
I_{RMS} current A ^{*1}	100% AC	43	72	86	144	180	217	304
	150% AC 1 min in 10 min	64,5	108	129	216	270	325,5	456
Heat loss W ^{*1}	242	352	374	488	692	743	905	
Allowable voltage fluctuation	-15% to 10%							
Power frequency	50 Hz							
Efficiency η	98,5-99,5%							
Degree of protection	IP20							
Ambient humidity	85% RH or less (without condensation)							
Storage temperature	-25 to 55°C							
Ambient temperature	-20 to 45°C							

*1 At nominal voltage 400 V, 50 Hz.

Regenerative Braking unit system

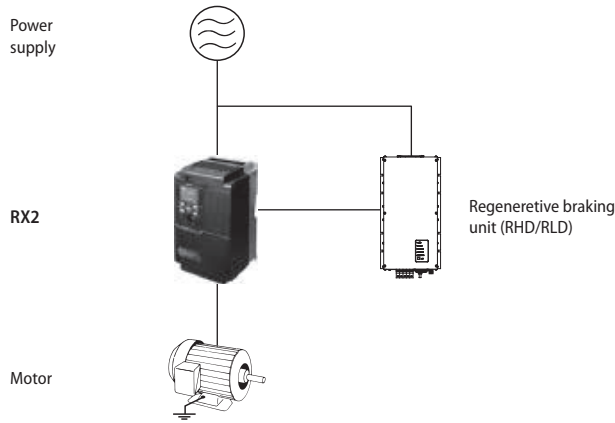

Regenerative Braking unit for Low Duty applications (50%)

Reference: RLD-E0_	8	12	16	20	24	32	40	48	58	80	95	116	140	170	200	
Max. regenerative power kW	8	12	16	20	24	32	40	48	58	80	95	116	140	170	200	
DC capacity μ F	20		40		220		440				660					
Max. current A* ¹	DC	14	20	28	35	42	55	70	83	101	139	165	202	242	295	348
	AC	12	17	23	29	35	46	58	69	84	116	137	168	202	246	290
Allowable voltage fluctuation	-15% to 10%															
Mains frequency	50 to 60 Hz															
Efficiency η	98%															
Degree of protection	IP20															
Ambient humidity	85% RH or less (without condensation)															
Storage temperature	-25 to 55°C															
Ambient temperature	5 to 40°C															

*¹ At nominal voltage 400 V.

Regenerative Braking unit for High Duty applications

Reference: RHD-B0_	7	13	18	24	30	50	70	100	125	150				
Max. regenerative power kW	7	13	18	24	30	50	70	100	125	150				
DC capacity μ F	20		100		40		220		660		440		660	
Max. current A* ¹	DC I 100%	12	23	31	42	52	87	122	174	218	260			
	AC I _{eff} 100%	10	19	26	35	43	72	101	144	180	217			
	AC I _{eff} 60 s in 10 min	12	23	31	42	52	86	121	173	216	260			
Allowable voltage fluctuation	-15% to 10%													
Mains frequency	40 to 60 Hz													
Efficiency η	98%													
Degree of protection	IP20													
Ambient humidity	85% RH or less (without condensation)													
Storage temperature	-25 to 55°C													
Ambient temperature	5 to 40°C													

*¹ At nominal voltage 400 V.

Ordering information

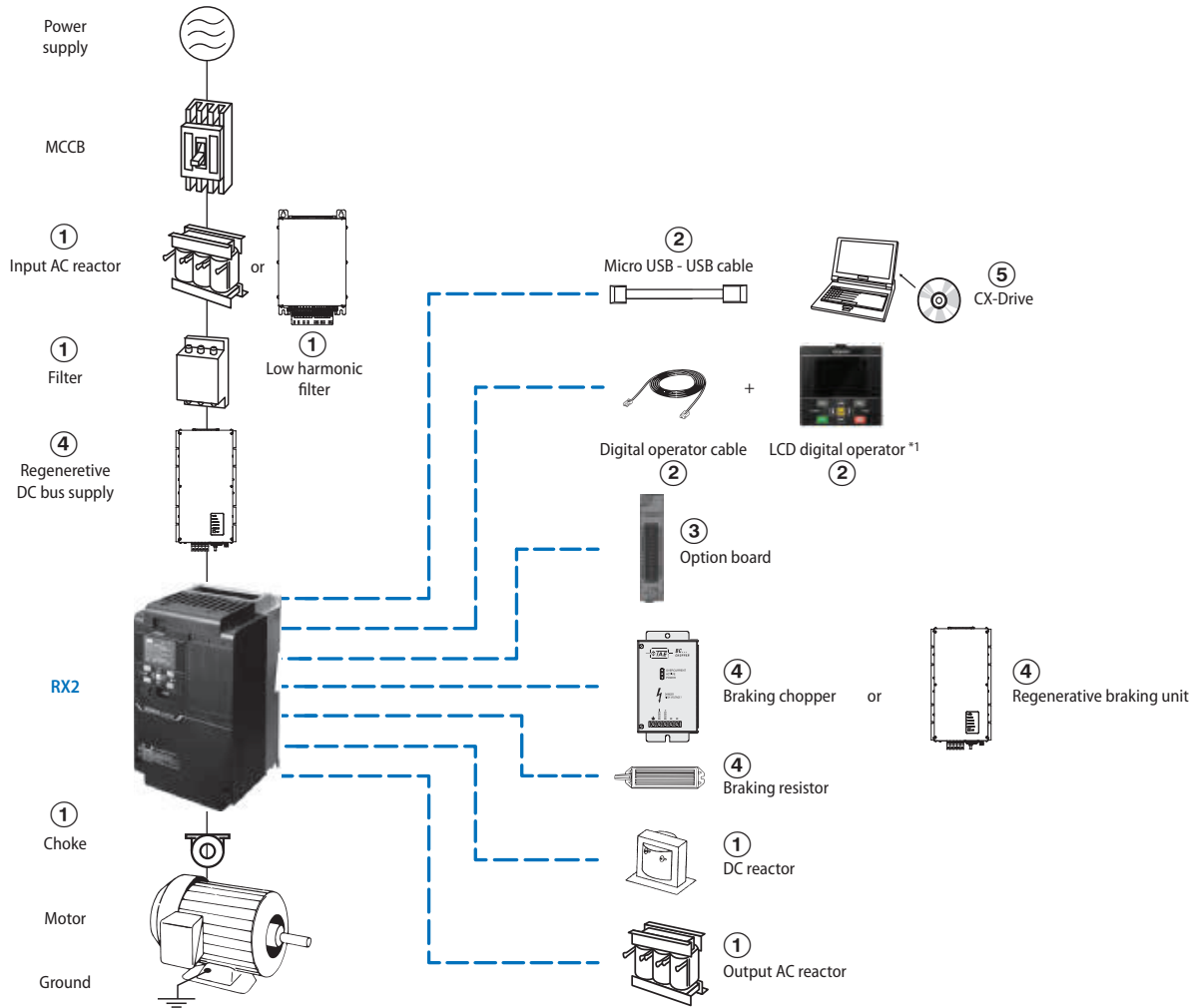

*1 The LCD digital operator is provided with the inverter from factory.

3G3RX2 inverter

Rated voltage	Protection class	Max. applicable motor capacity		Order code
		Normal Duty (ND)	Low Duty (LD)/ Very Low Duty (VLD)	
3-phase 200 VAC	IP20	0.4 kW	0.75 kW	3G3RX2-A2004
		0.75 kW	1.5 kW	3G3RX2-A2007
		1.5 kW	2.2 kW	3G3RX2-A2015
		2.2 kW	3.7 kW	3G3RX2-A2022
		3.7 kW	5.5 kW	3G3RX2-A2037
		5.5 kW	7.5 kW	3G3RX2-A2055
		7.5 kW	11 kW	3G3RX2-A2075
		11 kW	15 kW	3G3RX2-A2110
		15 kW	18.5 kW	3G3RX2-A2150
		18.5 kW	22 kW	3G3RX2-A2185
		22 kW	30 kW	3G3RX2-A2220
		30 kW	37 kW	3G3RX2-A2300
		37 kW	45 kW	3G3RX2-A2370
		45 kW	55 kW	3G3RX2-A2450
55 kW	75 kW	3G3RX2-A2550		

Rated voltage	Protection class	Max. applicable motor capacity		Order code
		Normal Duty (ND)	Low Duty (LD)/ Very Low Duty (VLD)	
3-phase 400 VAC	IP20	0.75 kW	1.5 kW	3G3RX2-A4007
		1.5 kW	2.2 kW	3G3RX2-A4015
		2.2 kW	3.7 kW	3G3RX2-A4022
		3.7 kW	5.5 kW	3G3RX2-A4037
		5.5 kW	7.5 kW	3G3RX2-A4055
		7.5 kW	11 kW	3G3RX2-A4075
		11 kW	15 kW	3G3RX2-A4110
		15 kW	18.5 kW	3G3RX2-A4150
		18.5 kW	22 kW	3G3RX2-A4185
		22 kW	30 kW	3G3RX2-A4220
		30 kW	37 kW	3G3RX2-A4300
		37 kW	45 kW	3G3RX2-A4370
		45 kW	55 kW	3G3RX2-A4450
		55 kW	75 kW	3G3RX2-A4550
	IP00	75 kW	90 kW	3G3RX2-B4750
		90 kW	110 kW	3G3RX2-B4900
		110 kW	132 kW	3G3RX2-B411K
		132 kW	160 kW	3G3RX2-B413K

Accessories

① Line filter

Schaffner line filter									
3-phase 200 V					3-phase 400 V				
Model 3G3RX2-__	Order code	Rated current A	Leakage current	Weight (kg)	Model 3G3RX2-__	Order code	Rated current A	Leakage current	Weight (kg)
A2004/A2007/ A2015/A2022/ A2037	AX-FIR2021-SE	21	1.44 mA	1.5	A4007/A4015/ A4022/A4037	AX-FIR4011-SE	11	3.1 mA	1.2
A2055/A2075/ A2110	AX-FIR2055-SE	55	1.53 mA	2.5	A4055/A4075/ A4110	AX-FIR4030-SE	30	3.3 mA	2
A2150/A2185/ A2220	AX-FIR2114-SE	114	2.15 mA	-	A4150/A4185/ A4220	AX-FIR4058-SE	58	3.3 mA	3
A2300	AX-FIR4146-SE	146	3.2 mA	6.6	A4300	AX-FIR4073-SE	73	3.75 mA	4.3
A2370/A2450/ A2550	AX-FIR4310-SE	310	3.8 mA	9.5	A4370	AX-FIR4090-SE	90	3.75 mA	5.1
					A4450/A4550	AX-FIR4146-SE	146	6.95 mA	6.6
					B4750/B4900/ B411K/B413K	AX-FIR4310-SE	310	8.2 mA	9.5

① Input AC reactor

3-phase 200 V		3-phase 400 V	
Model 3G3RX2-__	Order code	Model 3G3RX2-__	Order code
A2004/A2007/A2015	AX-RAI02800100-DE	A4007/A4015	AX-RAI07700050-DE
A2022/A2037	AX-RAI00880200-DE	A4022/A4037	AX-RAI03500100-DE
A2055/A2075	AX-RAI00350335-DE	A4055/A4075	AX-RAI01300170-DE
A2110 /A2150	AX-RAI00180670-DE	A4110/A4150	AX-RAI00740335-DE
A2185/A2220	AX-RAI00091000-DE	A4185/A4220	AX-RAI00360500-DE
A2300/A2370	AX-RAI00071550-DE	A4300/A4370	AX-RAI00290780-DE
A2450/A2550	AX-RAI00042300-DE	A4450/A4550	AX-RAI00191150-DE
		B4750/B4900	AX-RAI00111850-DE
		B411K/B413K	AX-RAI00072700-DE

① DC reactor

3-phase 200 V		3-phase 400 V	
Model 3G3RX2-__	Order code	Model 3G3RX2-__	Order code
A2004	AX-RC10700032-DE	A4007	AX-RC27000030-DE
A2007	AX-RC06750061-DE	A4015	AX-RC14000047-DE
A2015	AX-RC03510093-DE	A4022	AX-RC10100069-DE
A2022	AX-RC02510138-DE	A4037	AX-RC06400116-DE
A2037	AX-RC01600223-DE	A4055	AX-RC04410167-DE
A2055	AX-RC01110309-DE	A4075	AX-RC03350219-DE
A2075	AX-RC00840437-DE	A4110	AX-RC02330307-DE
A2110	AX-RC00590614-DE	A4150	AX-RC01750430-DE
A2150	AX-RC00440859-DE	A4185/A4220	AX-RC01200644-DE
A2185/A2220	AX-RC00301275-DE	A4300	AX-RC00920797-DE
A2300	AX-RC00231662-DE	A4370	AX-RC00741042-DE
A2370	AX-RC00192015-DE	A4450	AX-RC00611236-DE

3-phase 200 V		3-phase 400 V	
Model 3G3RX2-__	Order code	Model 3G3RX2-__	Order code
A2450	AX-RC00162500-DE	A4550	AX-RC00501529-DE
A2500	AX-RC00133057-DE	B4750	AX-RC00372094-DE
		B4900	AX-RC00312446-DE
		B411K	AX-RC00252981-DE
		B413K	AX-RC00213613-DE

① Chokes

Diameter	Description	Order code
21	For 2.2 kW motors or below	AX-FER2102-PE
28	For 15 kW motors or below	AX-FER2815-PE
50	For 45 kW motors or below	AX-FER5045-PE
52	For 55 kW motors or above	AX-FER5255-PE

① Output AC reactor

3-phase 200 V		3-phase 400 V	
Model 3G3RX2-__	Order code	Model 3G3RX2-__	Order code
A2004	AX-RAO11500026-DE	A4007/A4015	AX-RAO16300038-DE
A2007	AX-RAO07600042-DE	A4022	AX-RAO11800053-DE
A2015	AX-RAO04100075-DE	A4037	AX-RAO07300080-DE
A2022	AX-RAO03000105-DE	A4055	AX-RAO04600110-DE
A2037	AX-RAO01830160-DE	A4075	AX-RAO03600160-DE
A2055	AX-RAO01150220-DE	A4110	AX-RAO02500220-DE
A2075	AX-RAO00950320-DE	A4150	AX-RAO02000320-DE
A2110	AX-RAO00630430-DE	A4185	AX-RAO01650400-DE
A2150	AX-RAO00490640-DE	A4220	AX-RAO01300480-DE
A2185	AX-RAO00390800-DE	A4300	AX-RAO01030580-DE
A2220	AX-RAO00330950-DE	A4370	AX-RAO00800750-DE
A2300	AX-RAO00251210-DE	A4450	AX-RAO00680900-DE
A2370	AX-RAO00191450-DE	A4550	AX-RAO00531100-DE
A2450	AX-RAO00161820-DE	B4750	AX-RAO00401490-DE
A2500	AX-RAO00132200-DE	B4900	AX-RAO00331760-DE
		B411K	AX-RAO00262170-DE
		B413K	AX-RAO00212600-DE

Note: This table corresponds with HD rating. When ND is used, please choose the reactor for the next size inverter.

② Accessories

Type	Order code
Digital operator cable (RJ45 connector)	1 m length
	3 m length

③ Option boards

Type	Description	Order code
Encoder feedback	PG speed controller option board	A high accuracy operation which suppresses velocity fluctuation and positional control by pulse train position command input is achieved by feedback after detecting the rotation velocity of the encoder-equipped motor.
Communication option board	PROFIBUS option board	Used for running or stopping the inverter, setting or referencing parameters, and monitoring output frequency, output current... through communications with the host controller
	PROFINET option board	
	Modbus TCP option board	
	EtherCAT option board	

④ DC Supply with Regenerative Active Front End

Max. input power kW	Stand-alone			Kit
	Regenerative DC bus supply	Low harmonic filter	EMC filter	
30	RFE-B3 30-400-50-230-A-RVE	RHF-RA 43-400-50-20-A-RVE	RFI-RA 12-RVE	RFE-B3 30-400-50-230-IF-RVE
45	RFE-B3 45-400-50-230-A-RVE	RHF-RA 72-400-50-20-A-RVE	RFI-RA 23-RVE	RFE-B3 45-400-50-230-IF-RVE
60	RFE-B3 60-400-50-230-A-RVE	RHF-RA 86-400-50-20-A-RVE		RFE-B3 60-400-50-230-IF-RVE
80	RFE-B3 80-400-50-230-A-RVE	RHF-RA 144-400-50-20-A-RVE	RFI-RA X5-RVE	RFE-B3 80-400-50-230-IF-RVE
100	RFE-B3 100-400-50-230-A-RVE			RFE-B3 100-400-50-230-IF-RVE
125	RFE-B3 125-400-50-230-A-RVE	RHF-RA 180-400-50-20-A-RVE	RFI-RA X6-RVE	RFE-B3 125-400-50-230-IF-RVE
150	RFE-B3 150-400-50-230-A-RVE	RHF-RA 217-400-50-20-A-RVE	RFI-RA X6-RVE	RFE-B3 150-400-50-230-IF-RVE
200	RFE-B3 200-400-50-230-A-RVE	RHF-RA 304-400-50-20-A-RVE		RFE-B3 200-400-50-230-IF-RVE

Note: The DC Supply with Regenerative Active Front End kit includes a Regenerative DC bus supply, low harmonic filter and EMC filter.

④ Regenerative Braking unit

Low Duty applications (50%)		High Duty applications	
Max. regenerative power kW	Regenerative braking unit	Max. regenerative power kW	Regenerative braking unit
8	RLD-E0 8-400-50-0-A-RVE	7	RHD-B0 7-400-50-0-A-RVE
12	RLD-E0 12-400-50-0-A-RVE	13	RHD-B0 13-400-50-0-A-RVE
16	RLD-E0 16-400-50-0-A-RVE	18	RHD-B0 18-400-50-0-A-RVE
20	RLD-E0 20-400-50-0-A-RVE	24	RHD-B0 24-400-50-0-A-RVE
24	RLD-E0 24-400-50-0-A-RVE	30	RHD-B0 30-400-50-230-A-RVE
32	RLD-E0 32-400-50-0-A-RVE	50	RHD-B0 50-400-50-230-A-RVE
40	RLD-E0 40-400-50-0-A-RVE	70	RHD-B0 70-400-50-230-A-RVE
48	RLD-E0 48-400-50-0-A-RVE	100	RHD-B0 100-400-50-230-A-RVE
58	RLD-E0 58-400-50-0-A-RVE	125	RHD-B0 125-400-50-230-A-RVE
80	RLD-E0 80-400-50-0-A-RVE	150	RHD-B0 150-400-50-230-A-RVE
95	RLD-E0 95-400-50-0-A-RVE		
116	RLD-E0 116-400-50-0-A-RVE		
140	RLD-E0 140-400-50-0-A-RVE		
170	RLD-E0 170-400-50-230-A-RVE		
200	RLD-E0 200-400-50-230-A-RVE		

④ Braking unit, braking resistor unit

Inverter					Braking resistor unit					
Voltage	Max. motor kW	Model 3G3RX2-_ 3-phase	Braking unit AX- BCR_	Connectable min. resistance	Inverter mounted type (3%ED, 10 sec max)		Braking torque %	External resistor 10%ED, 10 sec max for built-in, 5 sec for braking unit		Braking torque %
					Type AX-_ Resistance	Resistance		Type AX-_ Resistance	Resistance	
200 V (three-phase)	0.55	A2004	Built-in	50 Ω	REM00K1200-IE	200 Ω	180	REM00K1200-IE	200 Ω	180
	1.1	A2007			100		REM00K2070-IE	70 Ω	200	
	1.5	A2015			35 Ω	140	REM00K4075-IE	75 Ω	130	
	2.2	A2022		90		REM00K4035-IE	35 Ω	180		
	4.0	A2037		50		REM00K6035-IE		100		
	5.5	A2055		16 Ω	75	REM00K9020-IE	20 Ω	150		
	7.5	A2075			10 Ω	55	REM01K9017-IE	17 Ω	110	
	11.0	A2110				40	REM02K1017-IE		75	
	15.0	A2150		7.5 Ω	55	REM03K5010-IE	10 Ω	95		
	18.5	A2185			75	REM19K0008-IE	8 Ω	95		
	22.0	A2220		5 Ω	65			80		
	30.0	A2300			4 Ω		REM19K0006-IE	6 Ω	80	
	37.0	A2370						60		
	45.0	A2450		2070130-TE	2.8 Ω		2 × REM19K0006-IE	3 Ω	105	
	55.0	A2550							85	
400 V (three-phase)	1.1	A4007	Built-in	100 Ω	REM00K1400-IE	400 Ω	200	REM00K1400-IE	400 Ω	200
	1.5	A4015			190		REM00K2200-IE	200 Ω	190	
	2.2	A4022			130	REM00K5120-IE	120 Ω	200		
	3.7	A4037		70 Ω	120	REM00K6100-IE	100 Ω	140		
	5.5	A4055			140	REM00K9070-IE	70 Ω	150		
	7.5	A4075		35 Ω	100	REM01K9070-IE		110		
	11.0	A4110			50	REM02K1070-IE		75		
	15.0	A4150		24 Ω	55	REM03K5035-IE	35 Ω	110		
	18.5	A4185			90	REM19K0030-IE	30 Ω	100		
	22.0	A4220		20 Ω	75			85		
	30.0	A4300					REM19K0020-IE	20 Ω	95	
	37.0	A4370		11 Ω			REM38K0012-IE	15 Ω	125	
	45.0	A4450			4017068-TE				100	
	55.0	A4550		4035090-TE	8.5 Ω		2 × REM19K0020-IE	10 Ω	100	
	75.0	B4750						3 × REM19K0030-IE		75
	90.0	B4900		4070130-TE	5.5 Ω		2 × REM38K0012-IE	6 Ω	105	
	110.0	B411K		4090240-TE	3.2 Ω		3 × REM38K0012-IE	4 Ω	125	
132.0	B413K							105		

⑤ Computer software

Type	Description	Order code
Computer software	Configuration and monitoring software tool	CX-Drive CX-One
	Software tool for energy saving calculation	€Saver

ALL DIMENSIONS SHOWN ARE IN MILLIMETERS.
To convert millimeters into inches, multiply by 0.03937. To convert grams into ounces, multiply by 0.03527.