

REV.	DESCRIPTION	DRAWN	DATE
2	Add A & E Key SPEC.	FROS	2018/10/09
3	CORRECTED	TIM	2019/06/10
3.1	CORRECTED	TIM	2019/12/11

Notes:

Material:

- Housing: High Temperature Thermoplastic, UL94V-0, Black
- Contacts: Copper Alloy, gold plated on contact area and gold flash solder area. 50u" min nickel under-plating overall.
- △ Peg: Copper Alloy, 50~120u" min matte-tin plated on soldering area. 50u" min. nickel under-plating.
- Reflow Solder Capable to 260°C
- Datecode: YYWWD
- How to order:

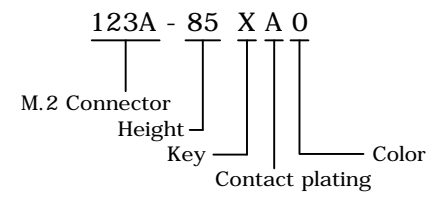

		DIMENSION TABLE							
P/N	Key	DIM.A	DIM.B	DIM.C	DIM.D	DIM.E	DIM.F	DIM.G	
123A-85MA0	M	-6.125	14.0	2.0	14.0	1.5	1.125	1.375	
123A-85EA0	E	2.625	5.5	10.5	5.0	10.5	1.375	1.125	
123A-85BA0	B	5.625	2.5	13.5	2.0	13.5	1.375	1.125	
123A-85AA0	A	6.625	1.5	14.5	1.0	14.5	1.125	1.375	

UNLESS OTHERWISE SPECIFIED TOLERANCE			
UNIT:	DECIMAL	LINEAR	ANGLES
mm	X.	±0.50	±5°
	X.X	±0.25	±3°
	X.XX	±0.12	±1°

DRAWN	Fros	2015/04/13	DRAWN NAME:
CHECKED	Zola	2015/04/13	M2 CONNECTOR
APPROVED	Albert	2015/04/13	A,B,E,M KEY, 0.5 PITCH, 8.5H
SCALE	3.5	SHEET 1/6	SIZE A4
FILE NAME	123A-85XA0_B_3.1		

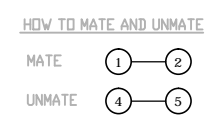
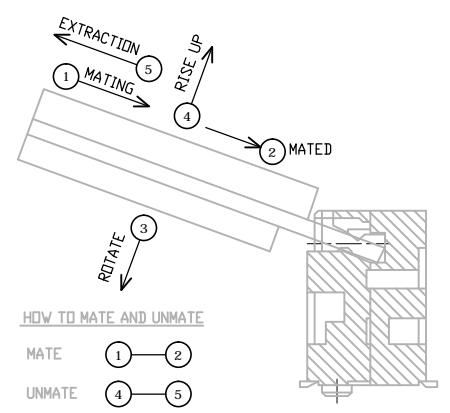
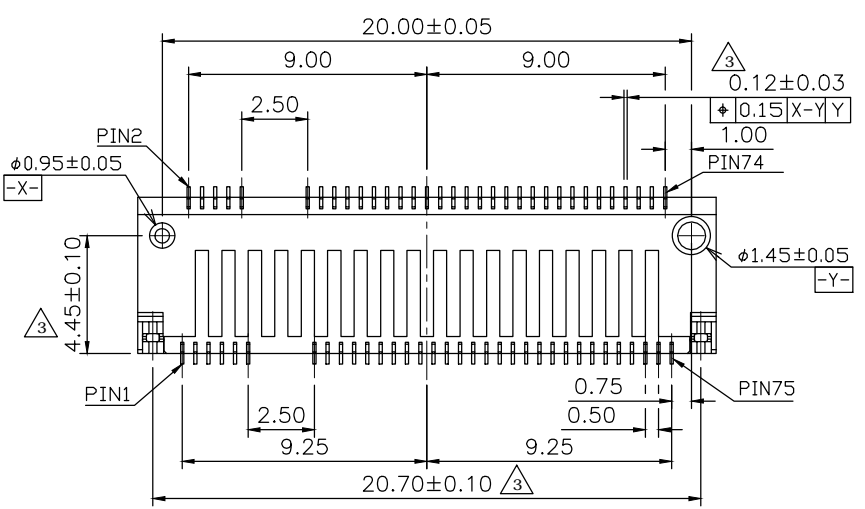
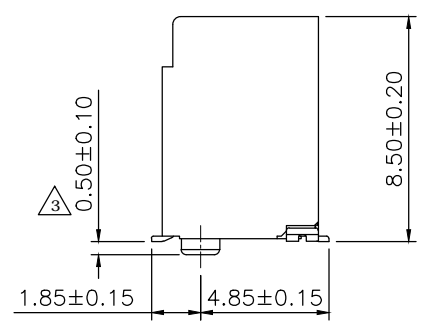
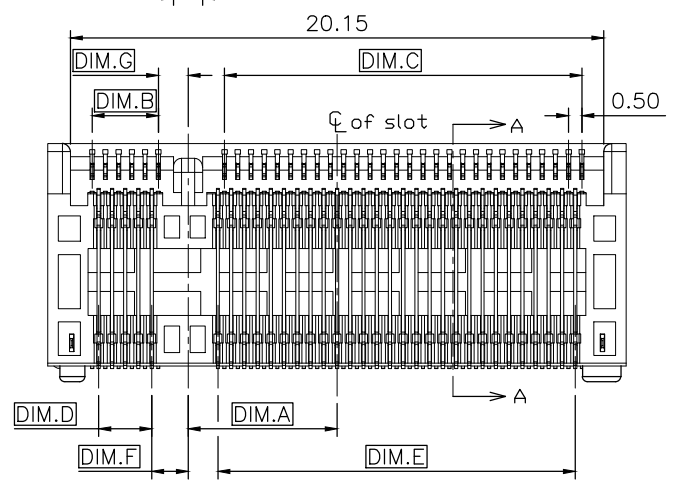
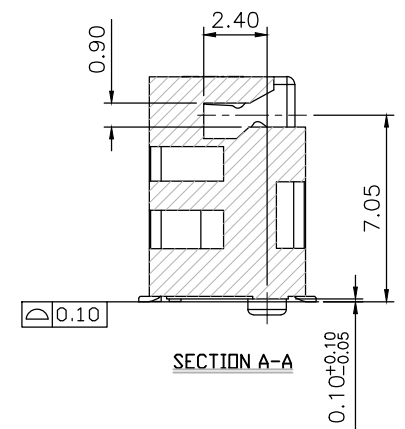
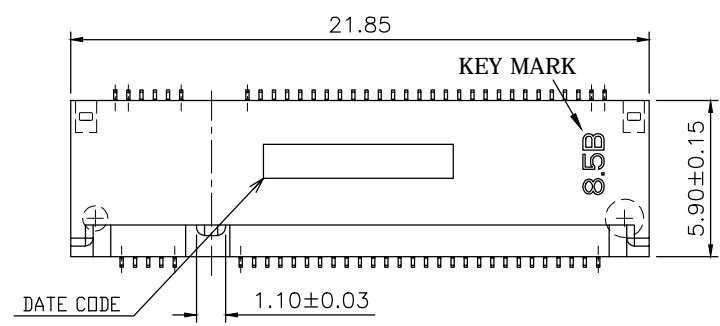

REV.	DESCRIPTION	DRAWN	DATE
	see sheet one		

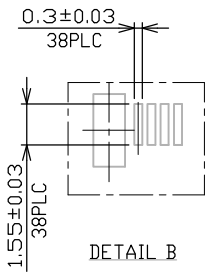
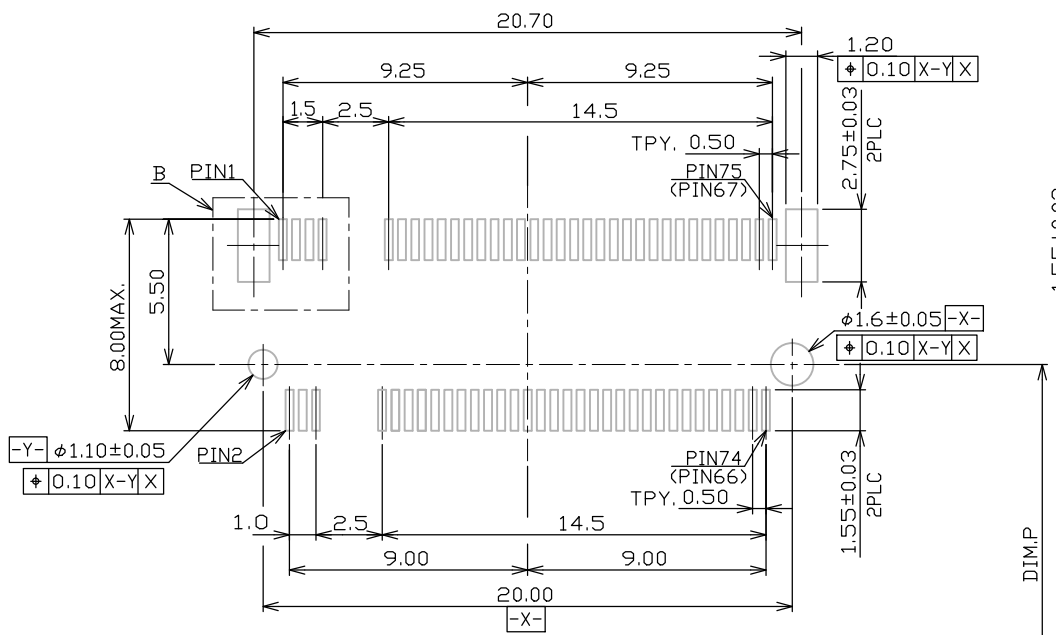
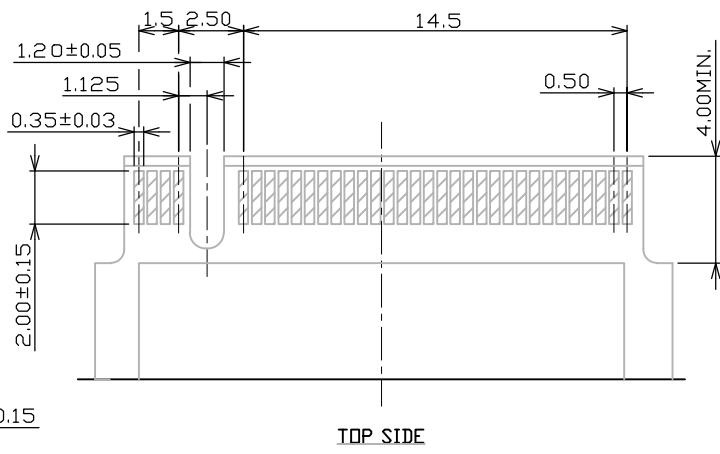
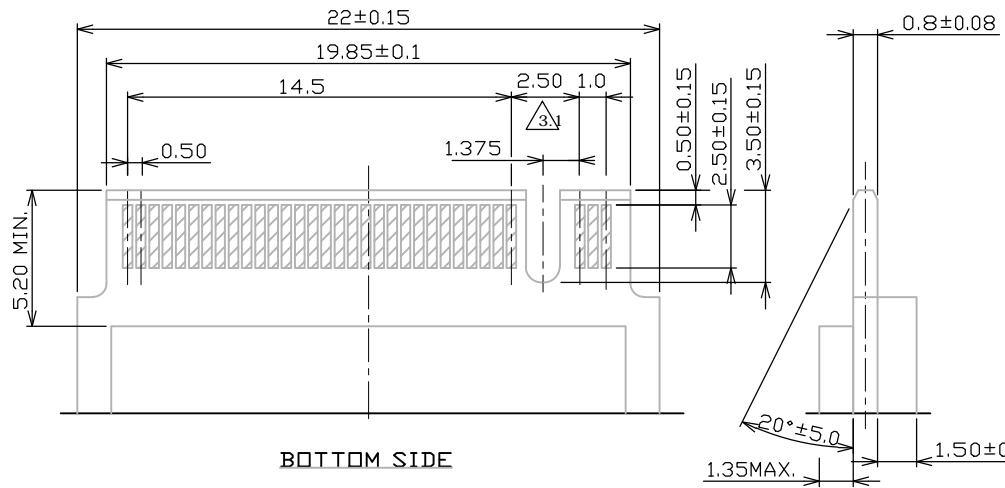

107.60	22110
77.60	2280
57.60	2260
39.60	2242
27.60	2230
39.60	3042
27.60	3030
DIM.P	MODULE TYPE

UNLESS OTHERWISE SPECIFIED TOLERANCE			
UNIT:	DECIMAL	LINEAR	ANGLES
mm	X.	±0.50	±5°
	X.X	±0.25	±3°
	X.XX	±0.12	±1°



WWW.ATTEND.COM.TW

DRAWN	Fros	2015/04/13	DRAWN NAME:
CHECKED	Zola	2015/04/13	LAYOUT, M2 CONNECTOR A-KEY, 0.5 PITCH, 8.5H
APPROVED	Albert	2015/04/13	PRODUCT NO. 123A-85AA0
SCALE	3.5	SHEET 2/6	SIZE A4
FILE NAME	123A-85XA0_B_3.1		

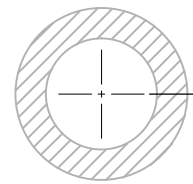

REV.	DESCRIPTION	DRAWN	DATE
	see sheet one		

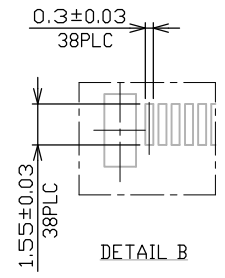
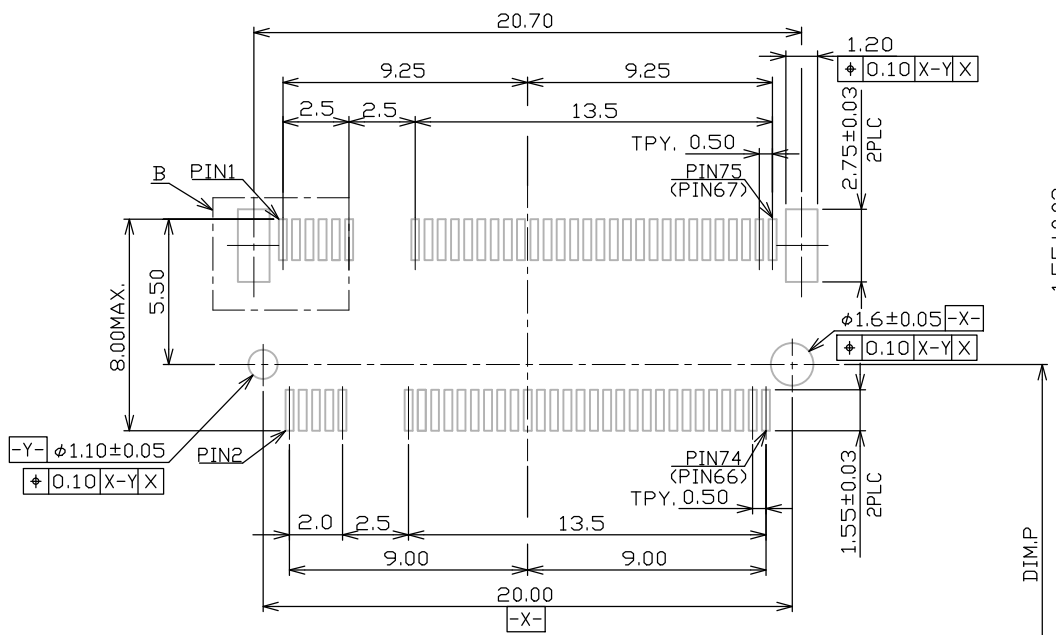
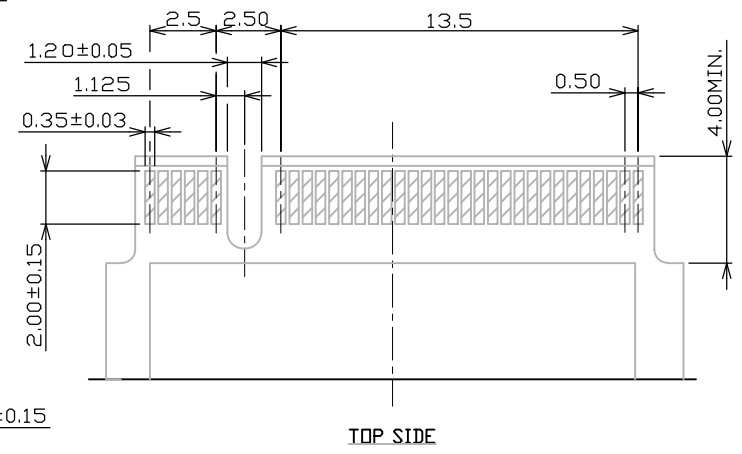
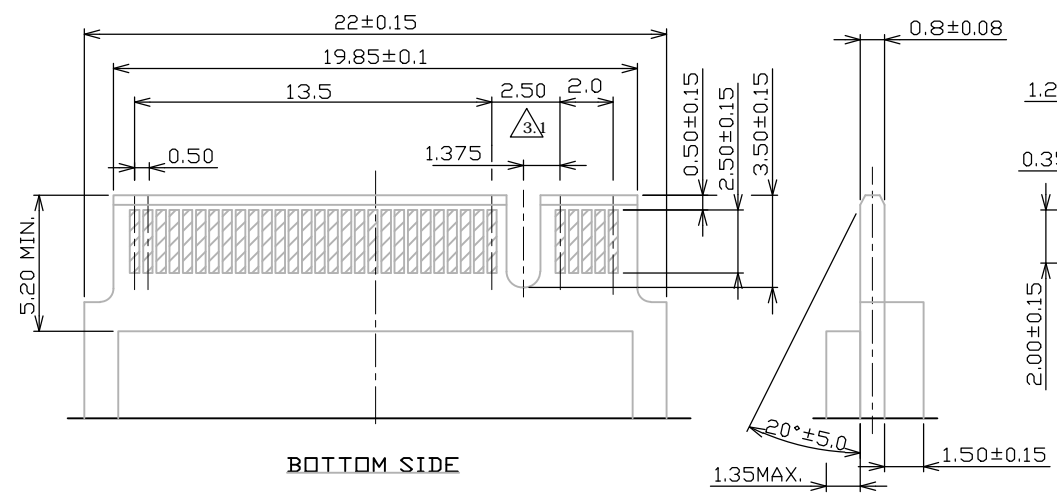

107.60	22110
77.60	2280
57.60	2260
39.60	2242
27.60	2230
39.60	3042
27.60	3030
DIM.P	MODULE TYPE

UNLESS OTHERWISE SPECIFIED TOLERANCE			
UNIT:	DECIMAL	LINEAR	ANGLES
mm	X.	±0.50	±5°
	X.X	±0.25	±3°
	X.XX	±0.12	±1°



WWW.ATTEND.COM.TW

DRAWN	Fros	2015/04/13	DRAWN NAME:
CHECKED	Zola	2015/04/13	LAYOUT, M2 CONNECTOR B-KEY, 0.5 PITCH, 8.5H
APPROVED	Albert	2015/04/13	PRODUCT NO. 123A-85BA0
SCALE	3.5	SHEET 3/6	SIZE A4
FILE NAME	123A-85XA0_B_3.1		

RECOMMENDED P.C.BOARD LAYOUT

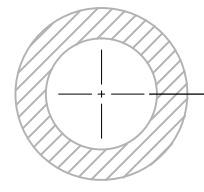

REV.	DESCRIPTION	DRAWN	DATE
	see sheet one		

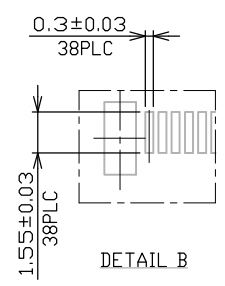
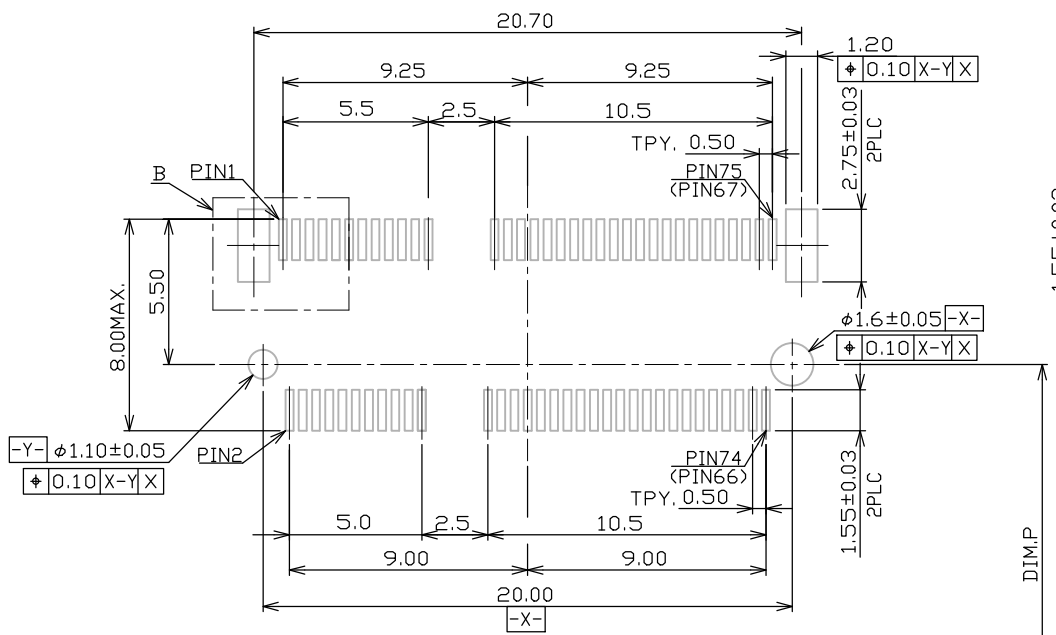
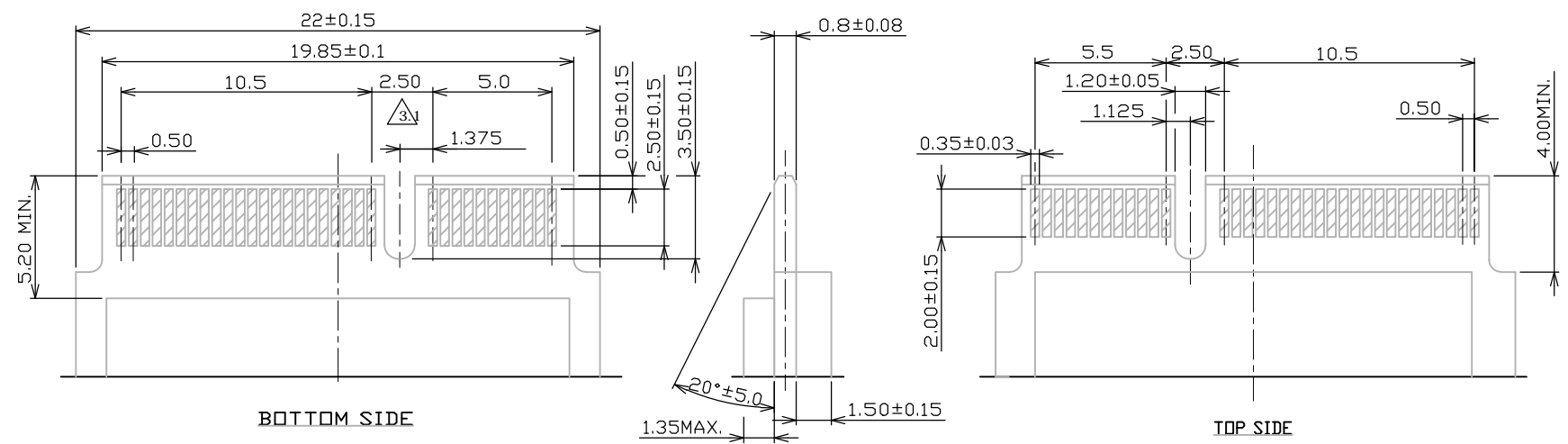

107.60	22110
77.60	2280
57.60	2260
39.60	2242
27.60	2230
39.60	3042
27.60	3030
DIM.P	MODULE TYPE

UNLESS OTHERWISE SPECIFIED TOLERANCE							
UNIT:	DECIMAL	LINEAR	ANGLES				
mm	X.	±0.50	±5°				
	X.X	±0.25	±3°				
	X.XX	±0.12	±1°				
DRAWN	Fros	2015/04/13	DRAWN NAME: LAYOUT, M2 CONNECTOR E-KEY, 0.5 PITCH, 8.5H				
CHECKED	Zola	2015/04/13					
APPROVED	Albert	2015/04/13					
SCALE	3.5	SHEET	4/6	SIZE	A4	FILE NAME	123A-85XA0_B_3.1

 **ATTEND**

WWW.ATTEND.COM.TW

RECOMMENDED P.C.BOARD LAYOUT

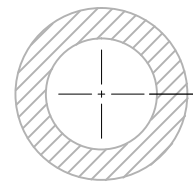

REV.	DESCRIPTION	DRAWN	DATE
	see sheet one		

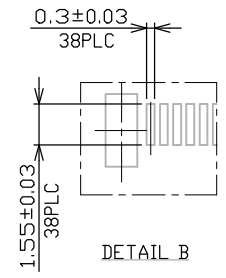
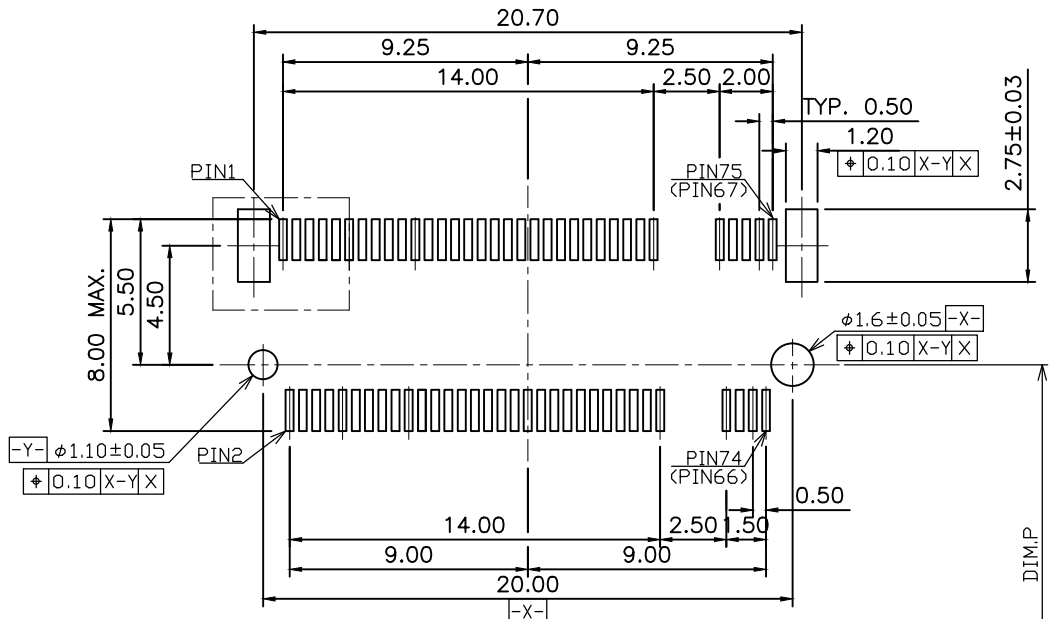
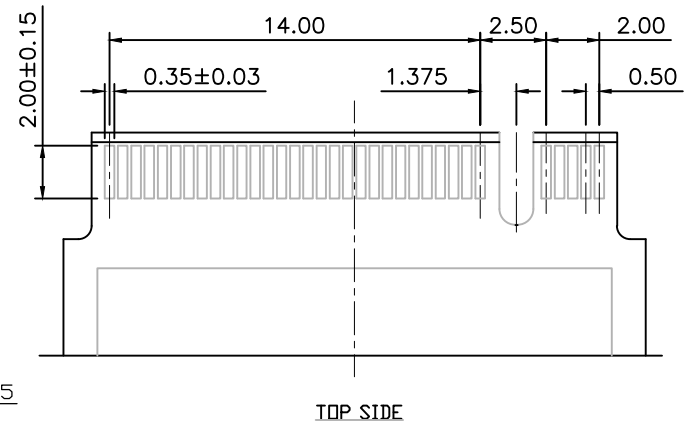
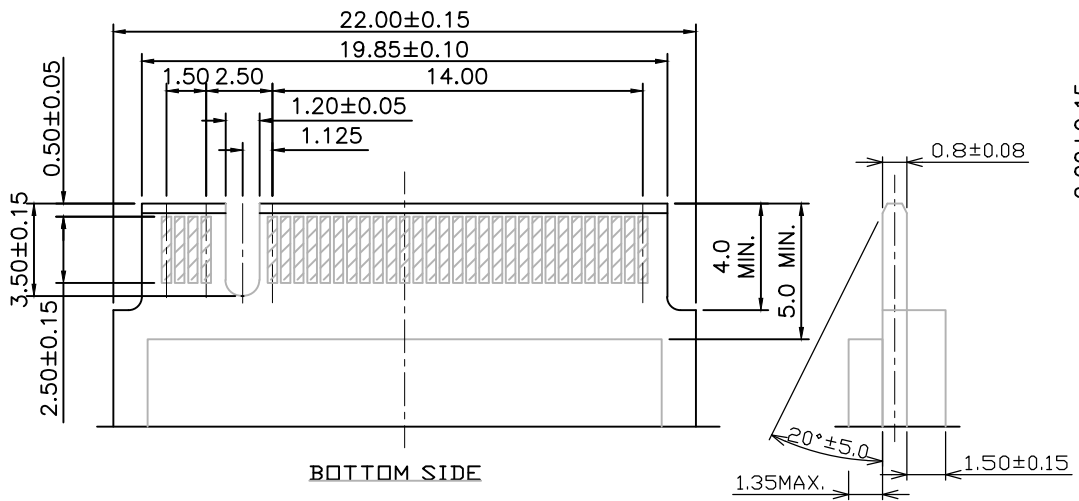

107.60	22110
77.60	2280
57.60	2260
39.60	2242
27.60	2230
39.60	3042
27.60	3030
DIM,P	MODULE TYPE

UNLESS OTHERWISE SPECIFIED TOLERANCE					
UNIT:	DECIMAL	LINEAR	ANGLES		
mm	X.	±0.50	±5°	WWW.ATTEND.COM.TW	
	X.X	±0.25	±3°		
	X.XX	±0.12	±1°		
DRAWN	Fros	2015/04/13	DRAWN NAME:		
CHECKED	Zola	2015/04/13	LAYOUT, M2 CONNECTOR		
APPROVED	Albert	2015/04/13	M-KEY, 0.5 PITCH, 8.5H		
SCALE	3.5	SHEET	5/6	SIZE	A4
FILE NAME	123A-85XA0_B_3.1				

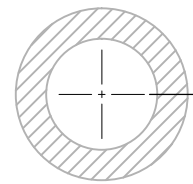

RECOMMENDED P.C.BOARD LAYOUT

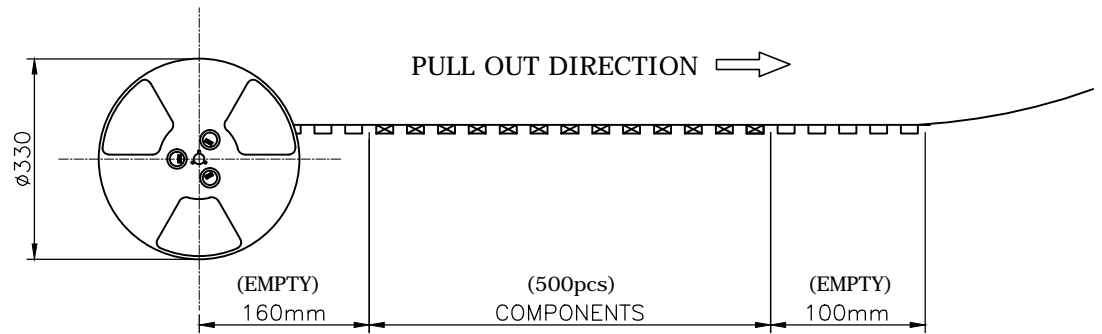

REV.	DESCRIPTION	DRAWN	DATE
	see sheet one		

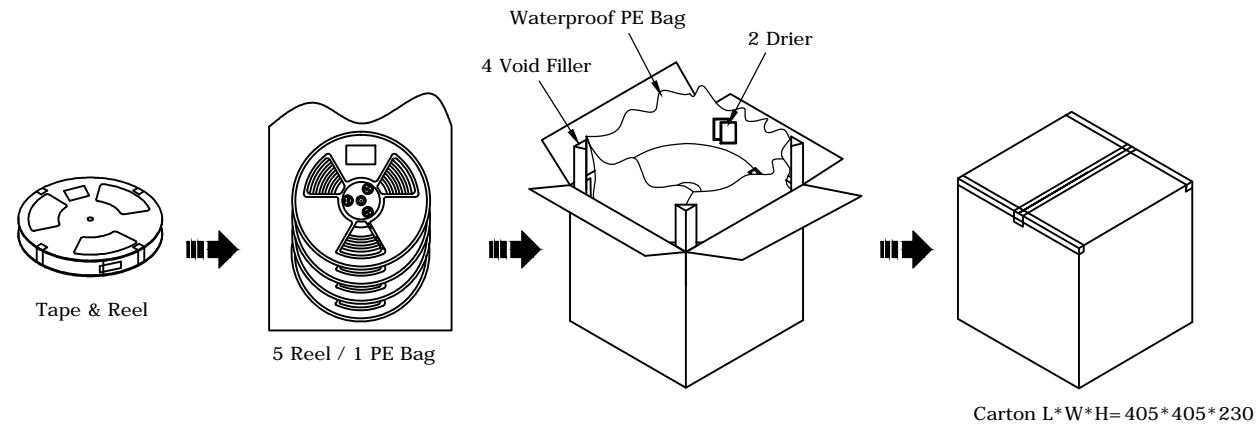
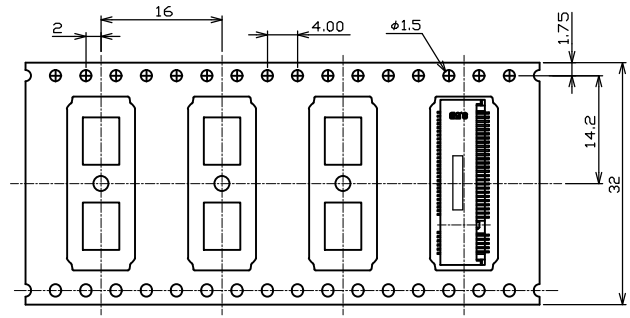

PACKAGING SPECIFICATION:

Quantity:
 500 Piece/ Reel
 5 Reel/ Carton
 2,500 Piece/ Outer Carton



UNLESS OTHERWISE SPECIFIED TOLERANCE				 WWW.ATTEND.COM.TW
UNIT:	DECIMAL	LINEAR	ANGLES	
mm	X.	±0.50	±5°	
	X.X	±0.25	±3°	
	X.XX	±0.12	±1°	
DRAWN	Fros	2015/04/13	DRAWN NAME:	
CHECKED	Zola	2015/04/13	PACKAGING, M2 CONNECTOR A,B,E,M-KEY, 0.5 PITCH, 8.5H	
APPROVED	Albert	2015/04/13	PRODUCT NO. see table	
	SCALE N/A	SHEET 6/6	SIZE A4	FILE NAME 123A-85XA0_B_3.1

REV.	DESCRIPTION	DRAWN	DATE
1	INITIAL RELEASE	FROS	2016/12/28

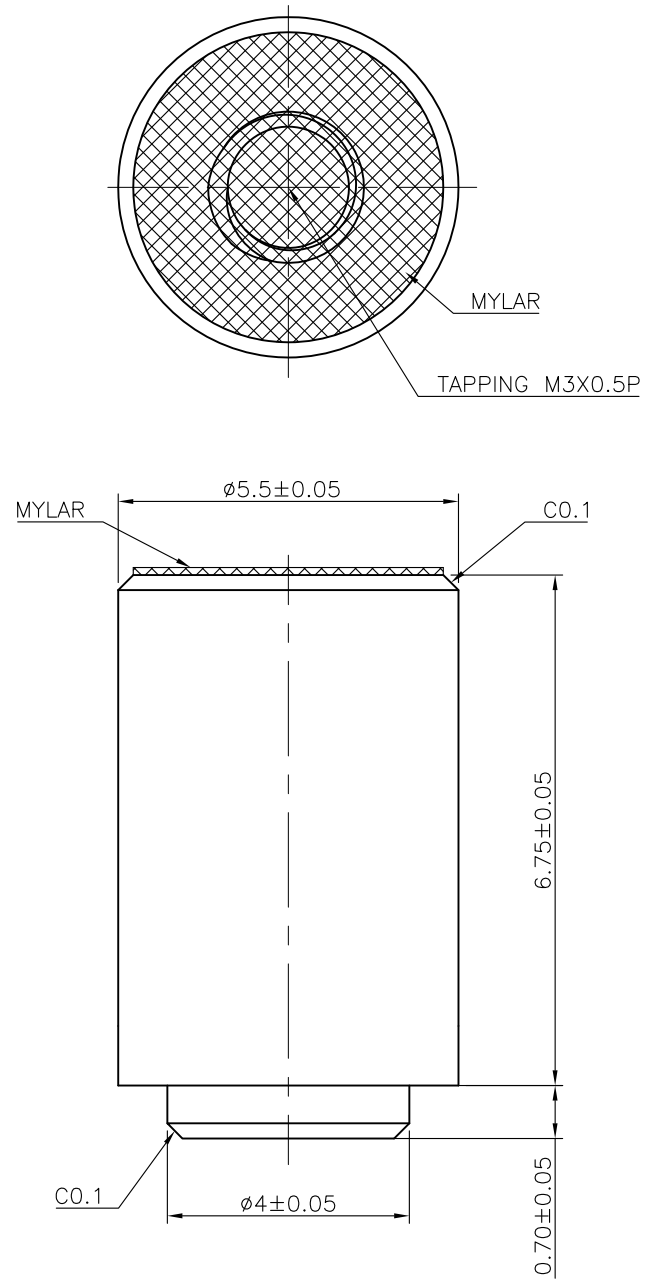

NOTE:
 1.MATERIAL: Copper Alloy
 2.Plating: Sn.
 3.Tape & Reel Packing, 500pcs/ reel

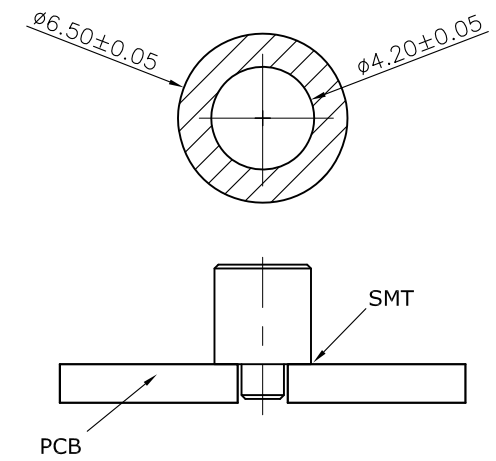

PCB Recommend Layout Pattern

UNLESS OTHERWISE SPECIFIED TOLERANCE							
UNIT:	DECIMAL	LINEAR	ANGLES			WWW.ATTEND.COM.TW	
mm	X.	±0.50	±5°	DRAWN: Fros 2016/12/28 CHECKED: Tim 2016/12/28 APPROVED: Ken 2016/12/28 SCALE: 10/1 SHEET: 1/1 SIZE: A4			
	X,X	±0.25	±3°			DRAWN NAME: M.2 Connector Stand Off for 8.5H	
	X,XX	±0.12	±1°				

$\phi 5.5^{+0}_{-0.5}$

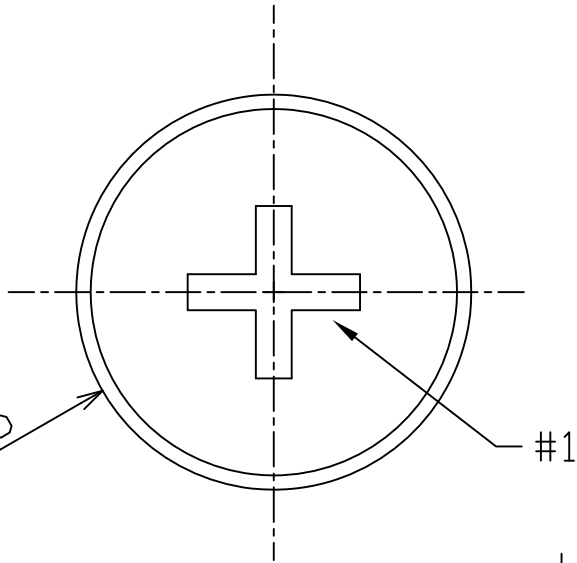

#1

$\phi 5.5^{+0}_{-0.5}$

0.8 ± 0.1

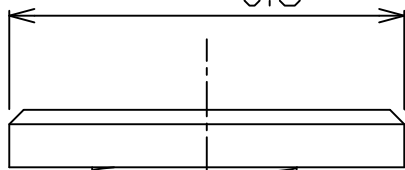

$2.5^{+0}_{-0.3}$

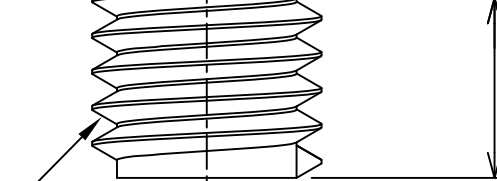

M3.0*P0.50

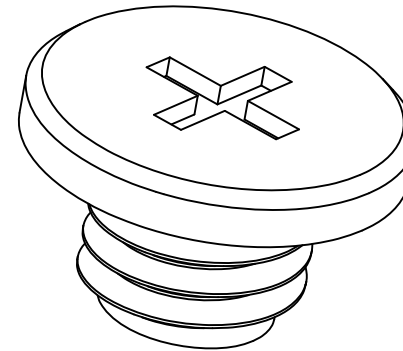

Note:
 1. Material: Low-carbon steel
 2. Plating: Nickel

UNLESS OTHERWISE SPECIFIED TOLERANCE		
ANGLES	ANG.	±5°
LINEAR	0.	±0.3
	0.0	±0.25
	0.00	±0.20
SCALE	AS SHOWN	UNIT: mm
DRAWN	Willis	2013/08/06
CHECKED	Angel	2013/08/06
APPROVED	Ken	2013/08/06



www.attend.com.tw

REV.	DESCRIPTION	DATE	REV.	DESCRIPTION	DATE
1					
2					
3					
4					
5					
6					
7					

A ⚠ Revise: ⚠ Revise: ⚠ Revise:	DRAWN NAME: M.2 Series Screw	PRODUCT NO. 123A-SCREW
SIZE A4	REV. 1.0	FILE NAME 123A-SCREW_B_1